

Dell PowerEdge T630

Owner's Manual

Notes, cautions, and warnings

 **NOTE:** A NOTE indicates important information that helps you make better use of your product.

 **CAUTION:** A CAUTION indicates either potential damage to hardware or loss of data and tells you how to avoid the problem.

 **WARNING:** A WARNING indicates a potential for property damage, personal injury, or death.

2017 - 11

Rev. A05

Contents

1 Dell PowerEdge T630 server overview	8
Supported configurations for the PowerEdge T630 server.....	8
Front panel.....	10
2.5-inch hard drive chassis.....	10
3.5-inch hard drive chassis.....	12
LCD panel.....	15
Back panel.....	17
Diagnostic indicators.....	19
NIC indicator codes.....	20
Power supply unit indicator codes.....	20
Hard drive indicator codes.....	23
Locating Service Tag of your system.....	24
2 Converting the system from tower mode to rack mode.....	25
Preparing a system for conversion from tower mode to rack mode	25
3 Documentation resources.....	29
4 Technical specifications.....	31
Chassis dimensions.....	31
Chassis weight.....	32
Processor specifications.....	32
PSU specifications.....	32
System battery specifications	32
Expansion bus specifications.....	33
Memory specifications.....	33
Drive specifications.....	33
Hard drives.....	33
Optical drive.....	34
Ports and connectors specifications.....	34
Serial connector.....	34
Internal Dual SD Module.....	34
VGA ports.....	34
USB ports.....	34
NIC ports.....	35
Video specifications.....	35
Environmental specifications.....	35
Particulate and gaseous contamination specifications.....	36
Expanded operating temperature.....	37
Expanded operating temperature restrictions.....	38
5 Initial system setup and configuration.....	39

Setting up your system.....	39
iDRAC configuration.....	39
Options to set up iDRAC IP address.....	39
Log in to iDRAC.....	40
Options to install the operating system.....	40
Downloading the drivers and firmware.....	40
6 Pre-operating system management applications.....	41
Options to manage the pre-operating system applications.....	41
System Setup.....	41
Viewing System Setup.....	41
System Setup details.....	42
System BIOS.....	42
iDRAC Settings utility.....	62
Device Settings.....	63
Dell Lifecycle Controller.....	63
Embedded system management.....	63
Boot Manager.....	63
Viewing Boot Manager.....	63
Boot Manager main menu.....	64
PXE boot.....	65
7 Installing and removing system components.....	66
Safety instructions.....	67
Before working inside your system.....	67
After working inside your system.....	67
Recommended tools.....	68
Front bezel (optional).....	68
Removing the optional front bezel.....	68
Installing the optional front bezel.....	69
System feet.....	70
Removing the system feet.....	70
Installing the system feet.....	71
Caster wheels (optional)—tower mode.....	72
Removing caster wheels.....	72
Installing caster wheels.....	73
System cover.....	75
Removing the system cover.....	75
Installing the system cover.....	76
Inside the system.....	77
Cooling shroud.....	78
Removing the cooling shroud.....	78
Installing the cooling shroud.....	79
Cooling fans.....	79
Removing a cooling fan.....	80
Installing a cooling fan.....	81

Cooling-fan assembly (optional).....	82
Removing the optional cooling fan assembly	82
Installing the optional cooling fan assembly.....	83
System memory.....	84
General memory module installation guidelines.....	85
Mode-specific guidelines.....	85
Sample memory configurations.....	87
Removing memory modules.....	90
Installing memory modules.....	91
Flex bays.....	92
Removing a flex bay.....	92
Installing a flex bay.....	93
Hard drives.....	94
Removing a hot swappable hard drive or SSD.....	95
Installing a hot swappable hard drive.....	96
Removing a 2.5-inch hard drive blank.....	97
Installing a 2.5-inch hard drive blank.....	98
Removing a 3.5-inch hard drive blank.....	99
Installing a 3.5-inch hard drive blank.....	99
Installing a hot swappable 2.5-inch hard drive into a 3.5-inch hard drive adapter.....	100
Removing a 2.5-inch hot swappable hard drive from a 3.5-inch hard drive adapter.....	101
Installing a 3.5-inch hard drive adapter into a hot swap hard drive carrier.....	102
Removing a 3.5-inch hot swappable hard drive adapter from a 3.5-inch hot swappable hard drive carrier.....	103
Removing a hard drive from a hard drive carrier.....	104
Installing a hot swappable hard drive into a hot swappable hard drive carrier.....	104
Optical drives and tape drives.....	105
Removing the optical drive or tape drive.....	105
Installing the optical drive or tape drive.....	108
Removing the slim optical drive blank.....	109
Installing the slim optical drive blank.....	110
Internal USB memory key (optional).....	111
Replacing the optional internal USB memory key.....	111
Expansion card holder.....	112
Removing the expansion card holder.....	112
Installing the expansion card holder.....	113
Expansion cards.....	114
Expansion card installation guidelines.....	114
Removing an expansion card.....	116
Installing an expansion card.....	117
GPU card holder (optional).....	118
Removing the optional GPU card holder.....	118
Installing the optional GPU card holder.....	119
GPU cards (optional).....	120
GPU card installation guidelines.....	120
Removing an optional GPU card.....	121

Installing an optional GPU card.....	122
Internal dual SD module (optional).....	124
Removing the optional internal dual SD module.....	124
Installing the optional internal dual SD module	126
Internal SD card.....	128
Removing an internal SD card.....	128
Installing an internal SD card.....	128
Processors and heat sinks.....	129
Removing a heat sink.....	129
Removing a processor.....	130
Installing a processor.....	133
Installing a heat sink.....	135
Power supply unit.....	137
Hot spare feature.....	138
Removing an AC power supply unit.....	138
Installing an AC power supply unit.....	139
Wiring instructions for a DC power supply unit.....	140
Removing a DC power supply unit.....	143
Installing a DC power supply unit.....	143
Removing the power supply unit blank.....	145
Installing the power supply unit blank.....	145
System battery.....	146
Replacing the system battery.....	146
Hard drive backplane.....	147
Removing the hard drive backplane.....	148
Installing the hard drive backplane.....	165
SD vFlash media card (optional).....	172
Replacing an optional SD vFlash media card.....	173
Control panel assembly.....	173
Removing the control panel assembly.....	173
Installing the control panel assembly.....	175
System board.....	177
Removing the system board.....	177
Installing the system board.....	178
Trusted Platform Module.....	181
Installing the Trusted Platform Module.....	181
Initializing the TPM for BitLocker users.....	182
Initializing the TPM for TXT users.....	182
Power interposer board and power distribution board.....	183
Removing the power interposer board.....	183
Removing the power distribution board.....	184
Installing the power distribution board.....	185
Installing the power interposer board.....	186
8 Using system diagnostics.....	188
Dell Embedded System Diagnostics.....	188

Running the Embedded System Diagnostics from Boot Manager.....	188
Running the Embedded System Diagnostics from the Dell Lifecycle Controller.....	188
System diagnostic controls.....	189
9 Jumpers and connectors	190
System board connectors.....	190
System board jumper settings.....	192
Disabling a forgotten password.....	192
10 Troubleshooting your system.....	193
Safety first — for you and your system.....	193
Troubleshooting system startup failure.....	193
Troubleshooting external connections.....	194
Troubleshooting the video subsystem.....	194
Troubleshooting a USB device.....	194
Troubleshooting a serial I/O device.....	195
Troubleshooting a NIC.....	195
Troubleshooting a wet system.....	195
Troubleshooting a damaged system.....	196
Troubleshooting the system battery.....	197
Troubleshooting power supply units.....	197
Troubleshooting power source problems.....	197
Power supply unit problems.....	198
Troubleshooting cooling problems.....	198
Troubleshooting cooling fans.....	199
Troubleshooting system memory.....	199
Troubleshooting an internal USB key.....	200
Troubleshooting an SD card.....	200
Troubleshooting an optical drive.....	201
Troubleshooting a hard drive.....	202
Troubleshooting a storage controller.....	202
Troubleshooting expansion cards.....	203
Troubleshooting processors.....	204
11 Getting help.....	205
Contacting Dell.....	205
Documentation feedback.....	205
Accessing system information by using QRL.....	205
Quick Resource Locator (QRL) for PowerEdge T630.....	206

Dell PowerEdge T630 server overview

The Dell PowerEdge T630 rackable tower servers support up to:

- Intel Xeon E5-2600 v4 processors
- 24 DIMMs
- Eighteen 3.5 inch hard drives
- Four Dell PowerEdge Express Flash devices
- Thirty two 2.5 inch hard drives

NOTE: The T630 systems support only internal, hot-swappable hard drives.

Topics:

- [Supported configurations for the PowerEdge T630 server](#)
- [Front panel](#)
- [Back panel](#)
- [Diagnostic indicators](#)
- [Locating Service Tag of your system](#)

Supported configurations for the PowerEdge T630 server

The Dell PowerEdge T630 system supports the following configurations:

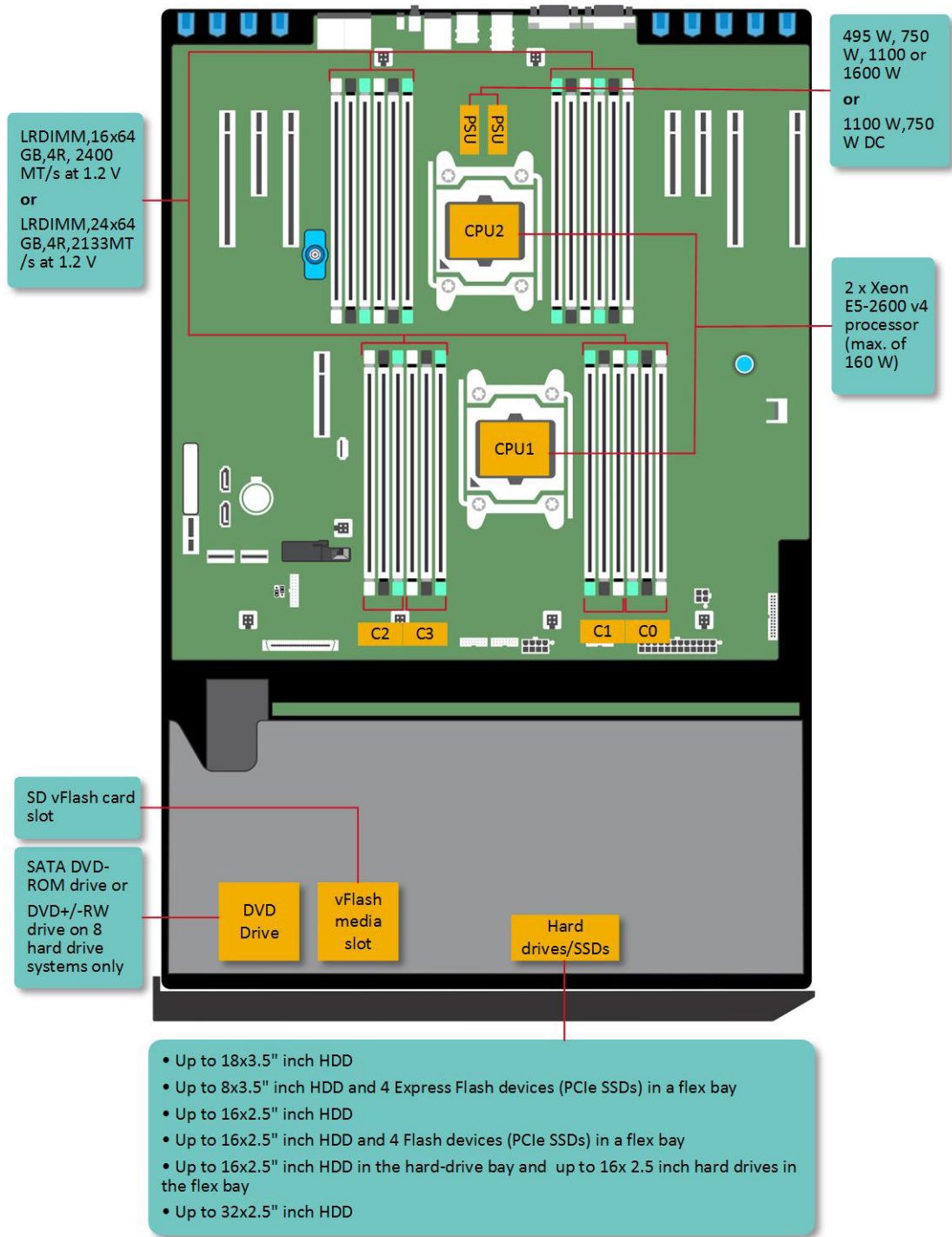

Figure 1. Supported configurations for the PowerEdge T630

Front panel

2.5-inch hard drive chassis

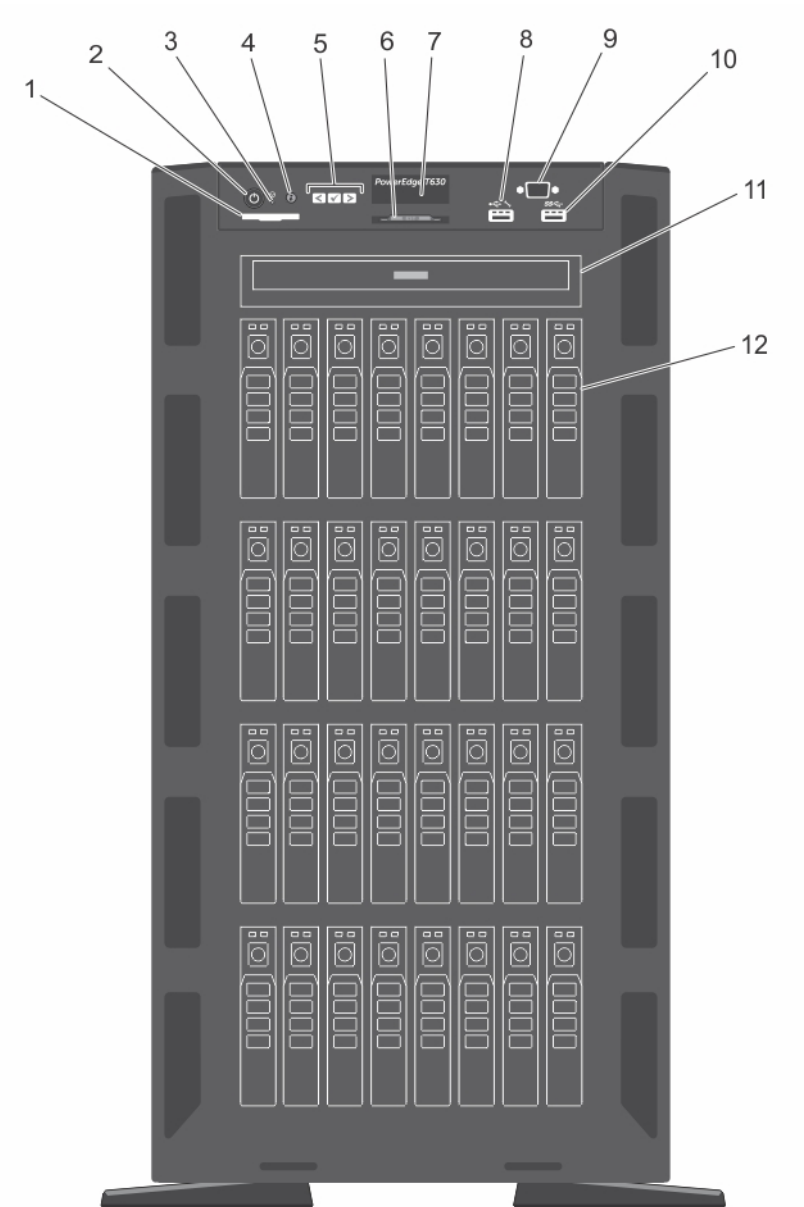







Figure 2. Front panel— 2.5-inch hard drive chassis

- | | | | |
|---|---------------------|---|------------------------------|
| 1 | SD vFlash card slot | 2 | power button |
| 3 | NMI button | 4 | System identification button |
| 5 | LCD menu buttons | 6 | Information tag |

7	LCD panel	8	iDRAC Direct port
9	VGA connector	10	USB connector
11	Optical drive or tapedrive bay	12	Physical drives

Table 1. Front panel button and connector description

Item	Button, or connector	Icon	Description
1	SD vFlash card slot		Use this to insert a vFlash media card. The vFlash media card is an SD card that extends the functionalities of the iDRAC enterprise card.
2	Power-on indicator, power button		<p>The power-on indicator turns on when the system power is on. The power button controls the power supply output to the system.</p> <p>NOTE: On ACPI-compliant operating systems, turning off the system using the power button causes the system to perform a graceful shutdown before power to the system is turned off.</p>
3	NMI button		<p>Use this button to troubleshoot software and device driver errors when running certain operating systems. This button can be pressed using the end of a paper clip.</p> <p>NOTE: Use this button only if directed to do so by qualified support personnel or by the operating system documentation.</p>
4	System identification button		<p>The identification buttons on the front and back panels can be used to locate a particular system within a rack. When one of these buttons is pressed, the LCD panel on the front and the system status indicator on the back flash until one of the buttons is pressed again.</p> <p>Press to toggle the system ID ON or OFF".</p> <p>If the system stops responding during POST, press and hold the system ID button for more than five seconds to enter BIOS progress mode.</p> <p>To reset iDRAC (if not disabled in <F2> iDRAC setup) press and hold for more than 15 seconds.</p>
5	LCD menu buttons		Use this button to navigate the control panel LCD menu.
6	Information tag		Contains system information such as service tag, NIC, MAC address for your reference. The information tag is a slide-out label panel.
7	LCD panel		<p>Displays system ID, status information, and system error messages. The LCD flashes blue during normal system operation. When the system needs attention, the LCD turns amber, and displays an error code followed by descriptive text.</p> <p>NOTE: If the system is connected to a power source and an error is detected, the LCD flashes amber regardless of whether the system is turned on or off.</p>

Item	Button, or connector	Icon	Description
8	USB management port/iDRAC Direct port		The USB management port can function as a regular USB port or provide access to the iDRAC Direct features. For more information, see the Integrated Dell Remote Access Controller User's Guide at Dell.com/idracmanuals . This port is USB 2.0-compliant
9	VGA connector		Allows you to connect a VGA display to the system. NOTE: The VGA connector is available only in the rack-mode configuration of your system. For information about converting your system from tower to the rack mode, see Preparing a system for conversion from tower mode to rack mode section .
10	USB connector		Use this to connect USB devices to the system. This port is USB 3.0-compliant.
11	Optical drive or tape-drive bay		Use this to install optical drives or tape drives. For more information on supported optical drives and tape drives, see the section Optical drives and tape drives section.
12	Physical drives		Up to thirty two 2.5-inch hard drives

Related link

[Preparing a system for conversion from tower mode to rack mode](#)

3.5-inch hard drive chassis

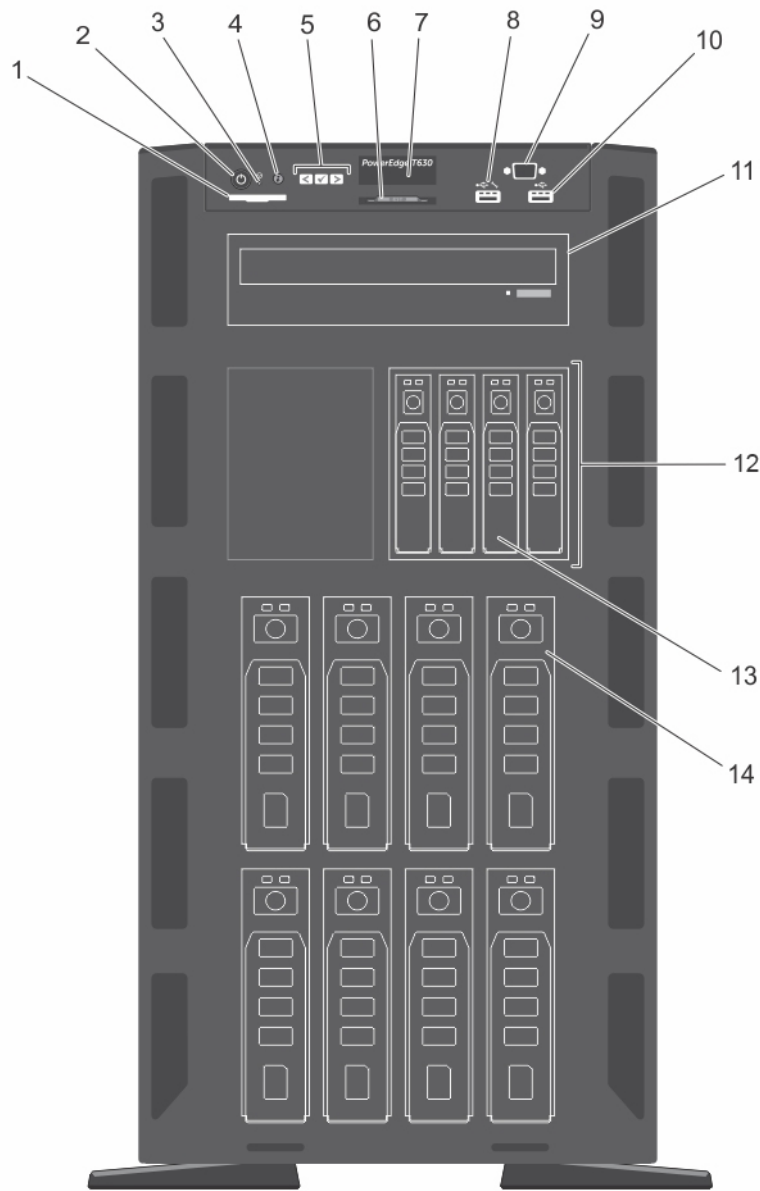







Figure 3. Front panel— 3.5-inch hard drive plus four PCIe SSD chassis

- | | | | |
|----|--------------------------------|----|------------------------------|
| 1 | SD vFlash card slot | 2 | power button |
| 3 | NMI button | 4 | System identification button |
| 5 | LCD menu buttons | 6 | Information tag |
| 7 | LCD panel | 8 | iDRAC Direct port |
| 9 | VGA connector | 10 | USB connector |
| 11 | Optical drive or tapedrive bay | 12 | Flex Bay |
| 13 | PCIe SSDs | 14 | 3.5-inch hard drives |

Table 2. Front panel button and connector description

Item	Button, or connector	Icon	Description
1	SD vFlash card slot		Use this to insert a vFlash media card. The vFlash media card is an SD card that extends the functionalities of the iDRAC enterprise card.
2	Power-on indicator, power button		<p>The power-on indicator turns on when the system power is on. The power button controls the power supply output to the system.</p> <p>NOTE: On ACPI-compliant operating systems, turning off the system using the power button causes the system to perform a graceful shutdown before power to the system is turned off.</p>
3	NMI button		<p>Use this button to troubleshoot software and device driver errors when running certain operating systems. This button can be pressed using the end of a paper clip.</p> <p>NOTE: Use this button only if directed to do so by qualified support personnel or by the operating system documentation.</p>
4	System identification button		<p>The identification buttons on the front and back panels can be used to locate a particular system within a rack. When one of these buttons is pressed, the LCD panel on the front and the system status indicator on the back flash until one of the buttons is pressed again.</p> <p>Press to toggle the system ID ON or OFF".</p> <p>If the system stops responding during POST, press and hold the system ID button for more than five seconds to enter BIOS progress mode.</p> <p>To reset iDRAC (if not disabled in <F2> iDRAC setup) press and hold for more than 15 seconds.</p>
5	LCD menu buttons		Use this button to navigate the control panel LCD menu.
6	Information tag		Contains system information such as service tag, NIC, MAC address for your reference. The information tag is a slide-out label panel.
7	LCD panel		<p>Displays system ID, status information, and system error messages. The LCD flashes blue during normal system operation. When the system needs attention, the LCD turns amber, and displays an error code followed by descriptive text.</p> <p>NOTE: If the system is connected to a power source and an error is detected, the LCD flashes amber regardless of whether the system is turned on or off.</p>
8	USB management port/iDRAC Direct port		<p>The USB management port can function as a regular USB port or provide access to the iDRAC Direct features. For more information, see the Integrated Dell Remote Access Controller User's Guide at Dell.com/idracmanuals.</p> <p>This port is USB 2.0-compliant</p>
9	VGA connector		Allows you to connect a VGA display to the system.

Item	Button, or connector	Icon	Description
			<p>NOTE: The VGA connector is available only in the rack-mode configuration of your system. For information about converting your system from tower to the rack mode, see Preparing a system for conversion from tower mode to rack mode section.</p>
10	USB connector		Use this to connect USB devices to the system. This port is USB 3.0-compliant.
11	Optical drive or tape-drive bay		Use this to install optical drives or tape drives. For more information on supported optical drives and tape drives, see the section Optical drives and tape drives section .
12	Flex Bay		Supports installation of up to four PCIe SSDs
13	PCIe SSDs		Up to four PCIe SSDs
14	Physical drives		Up to eight 3.5-inch hard drives

Related link

[Preparing a system for conversion from tower mode to rack mode](#)

LCD panel

The LCD panel of your system provides system information, status, and error messages to indicate if the system is functioning correctly or if the system needs attention. For more information about error messages, see the *Dell Event and Error Messages Reference Guide* at Dell.com/openmanagemanuals > **OpenManage software**.

- The LCD backlight turns blue during normal operating conditions.
 - When the system needs attention, the LCD turns amber, and displays an error code followed by descriptive text.
- NOTE:** If the system is connected to a power source and an error is detected, the LCD turns amber regardless of whether the system is turned on or off.
- The LCD backlight is turned off when the system is in standby mode and can be turned on by pressing either the Select, Left, or Right button on the LCD panel.
 - The LCD backlight remains off if LCD messaging is turned off using the iDRAC utility, the LCD panel, or other tools.

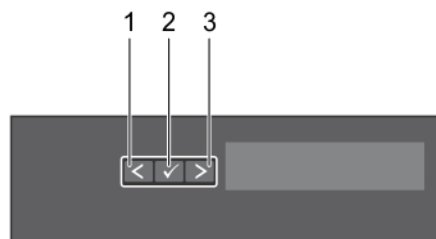

Figure 4. LCD panel features

Table 3. LCD panel features

Item	Button	Description
1	Left	Moves the cursor back in one-step increments.
2	Select	Selects the menu item highlighted by the cursor.



Item	Button	Description
3	Right	<p>Moves the cursor forward in one-step increments.</p> <p>During message scrolling:</p> <ul style="list-style-type: none"> Press and hold the button to increase scrolling speed. Release the button to stop. <p>NOTE: The display stops scrolling when the button is released. After 45 seconds of inactivity the display starts scrolling.</p>

Viewing Home screen

About this task

The **Home** screen displays user-configurable information about the system. This screen is displayed during normal system operation when there are no status messages or errors. When the system is in standby mode, the LCD backlight turns off after a few minutes of inactivity, if there are no error messages.

Steps

- To view the **Home** screen, press one of the three navigation buttons (Select, Left, or Right).
- To navigate to the **Home** screen from another menu, complete the following steps:
 - Press and hold the up arrow  until the **Home** icon  is displayed.
 - Select the **Home** icon.
 - On the **Home** screen, press the **Select** button to enter the main menu.

Setup menu

NOTE: When you select an option in the Setup menu, you must confirm the option before proceeding to the next action.

Option	Description
iDRAC	Select DHCP or Static IP to configure the network mode. If Static IP is selected, the available fields are IP , Subnet (Sub) , and Gateway (Gtw) . Select Setup DNS to enable DNS and to view domain addresses. Two separate DNS entries are available.
Set error	<p>Select SEL to view LCD error messages in a format that matches the IPMI description in the SEL. This enables you to match an LCD message with an SEL entry.</p> <p>Select Simple to view LCD error messages in a simplified user-friendly description. For more information about error messages, see the <i>Dell Event and Error Messages Reference Guide</i> at Dell.com/openmanagemanuals > OpenManage software.</p>
Set home	Select the default information to be displayed on the Home screen. See View menu section for the options and option items that can be set as the default on the Home screen.

Related link

[View menu](#)

View menu

NOTE: When you select an option in the View menu, you must confirm the option before proceeding to the next action.

Option	Description
iDRAC IP	Displays the IPv4 or IPv6 addresses for iDRAC8. Addresses include DNS (Primary and Secondary) , Gateway, IP , and Subnet (IPv6 does not have Subnet).
MAC	Displays the MAC addresses for iDRAC , iSCSI , or Network devices.
Name	Displays the name of the Host , Model , or User String for the system.
Number	Displays the Asset tag or the Service tag for the system.
Power	Displays the power output of the system in BTU/hr or Watts. The display format can be configured in the Set home submenu of the Setup menu.
Temperature	Displays the temperature of the system in Celsius or Fahrenheit. The display format can be configured in the Set home submenu of the Setup menu.

Back panel

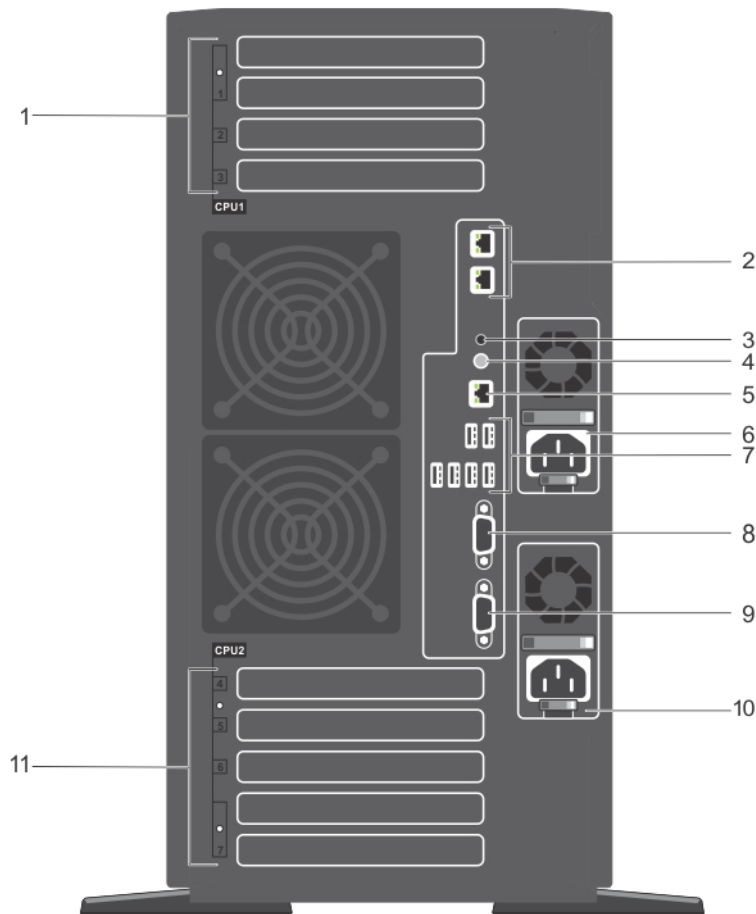







Figure 5. Back panel features

- | | | | |
|---|---|---|------------------------------|
| 1 | PCIe expansion card slots (3) (processor 1) | 2 | Ethernet connectors |
| 3 | System identification connector | 4 | System identification button |
| 5 | iDRAC Enterprise port | 6 | Power supply (PSU1) |
| 7 | USB port(6) | 8 | Video connector |

- 9 Serial connector
- 10 Power supply (PSU2)
- 11 Full-height PCIe expansion card slots (processor 2)

Table 4. Back panel indicator, button, or Connector description

Item	Indicator, Button, or Connector	Icon	Description
1	PCIe expansion card slots (3) (processor 1)		You can connect up to two PCI Express expansion cards and one PERC card.
2	Ethernet connectors		Two integrated 10/100/1000 Mbps NIC connectors.
3	System identification connector		It connects the optional system status indicator assembly through the optional cable management arm.
4	System identification button		<p>The identification buttons on the front and back panels can be used to locate a particular system within a rack. When one of these buttons is pressed, the LCD panel on the front and the system status indicator on the back flash until one of the buttons is pressed again.</p> <p>Press to toggle the system ID on and off.</p> <p>If the system stops responding during POST, press and hold the system ID button for more than five seconds to enter the BIOS progress mode.</p> <p>To reset iDRAC (if not disabled in F2 iDRAC setup), press and hold for more than 15 seconds.</p>
5	iDRAC Enterprise port		<p>Dedicated management port.</p> <p>NOTE: The port is available for use only if the iDRAC Enterprise license is installed on your system.</p>
6	Power supply (PSU1)		<p>AC 495 W, 750 W, 1100 W, or 1600 W</p> <p>or</p> <p>DC 1100 W</p>
7	USB port(6)		You can connect USB devices to the system. Four ports are USB 2.0-compliant and two ports are USB 3.0-compliant.
8	Video connector		You can connect a VGA display to the system.
9	Serial connector		You can connect a serial device to the system.
10	Power supply (PSU2)		<p>AC 495 W, 750 W, 1100 W, or 1600 W</p> <p>or</p> <p>DC 1100 W</p>
11	Full-height PCIe expansion card slots (processor 2)		Connects up to four full-height PCI Express expansion cards.

Diagnostic indicators

The diagnostic indicators on the system front panel display system status during system startup.

NOTE: The diagnostic indicators are not present if the system is equipped with an LCD display.

NOTE: No diagnostic indicators are lit when the system is turned off. To start the system, plug it into a working power source and press the power button.

Table 5. Diagnostic indicators







Icon	Description	Condition	Corrective action
	Health indicator	<p>The indicator turns solid blue if the system is in good health.</p> <p>The indicator flashes amber:</p> <ul style="list-style-type: none"> When the system is turned on. When the system is in standby. If any error condition exists. For example, a failed fan, PSU, or a hard drive. 	<p>None required.</p> <p>Check the System Event Log or system messages for the specific issue. For more information about error messages, see the <i>Dell Event and Error Messages Reference Guide</i> at Dell.com/openmanagemanuals > OpenManage software.</p> <p>The POST process is interrupted without any video output due to invalid memory configurations. See the Getting help section.</p>
	Hard drive indicator	The indicator flashes amber if there is a hard drive error.	Check the System Event Log to determine the hard drive that has an error. Run the appropriate Online Diagnostics test. Restart the system and run embedded diagnostics (ePSA). If the hard drives are configured in a RAID array, restart the system and enter the host adapter configuration utility program.
	Electrical indicator	The indicator flashes amber if the system experiences an electrical error (for example, voltage out of range, or a failed power supply unit (PSU) or voltage regulator).	Check the System Event Log or system messages for the specific issue. If it is due to a problem with the PSU, check the LED on the PSU. Reseat the PSU. If the problem persists, see the Getting help section.
	Temperature indicator	The indicator flashes amber if the system experiences a thermal error (for example, the ambient temperature is out of range or fan failure).	<p>Ensure that none of the following conditions exist:</p> <ul style="list-style-type: none"> A cooling fan has been removed or has failed. System cover, cooling shroud, EMI filler panel, memory module blank, or back filler bracket is removed. Ambient temperature is too high. External airflow is obstructed. <p>See the Getting help section.</p>
	Memory indicator	The indicator flashes amber if a memory error occurs.	Check the system event log or system messages for the location of the failed memory. Reseat the memory module. If the problem persists, see the Getting help section.
	PCIe indicator	The indicator flashes amber if a PCIe card experiences an error.	Restart the system. Update any required drivers for the PCIe card. Reinstall the card. If the problem persists, see the Getting help section.



Figure 7. AC PSU status indicator

1 AC PSU status indicator/handle

Table 7. AC PSU status indicators

Convention	Power indicator pattern	Condition
A	Green	A valid power source is connected to the PSU and the PSU is operational.
B	Flashing green	When the firmware of the PSU is being updated, the PSU handle flashes green.
C	Flashing green and turns off	When hot-adding a PSU, the PSU handle flashes green five times at 4 Hz rate and turns off. This indicates a PSU mismatch with respect to efficiency, feature set, health status, and supported voltage. <p>NOTE: Ensure that both the PSUs are of the same capacity.</p> <p>CAUTION: For AC PSUs, use only PSUs with the Extended Power Performance (EPP) label on the back.</p> <p>NOTE: Mixing PSUs from previous generations of Dell PowerEdge servers can result in a PSU mismatch condition or failure to turn the system on.</p>
D	Flashing amber	Indicates a problem with the PSU. <p>CAUTION: When correcting a PSU mismatch, replace only the PSU with the flashing indicator. Swapping the PSU to make a matched pair can result in an error condition and unexpected system shutdown. To change from a high output configuration to a low output configuration or vice versa, you must power down the system.</p> <p>CAUTION: AC PSUs support both 220 V and 110 V input voltages with the exception of Titanium PSUs, which support only 220 V. When two identical PSUs receive different input voltages, they can output different wattages, and trigger a mismatch.</p>

Convention	Power indicator pattern	Condition
		<p>⚠ CAUTION: If two PSUs are used, they must be of the same type and have the same maximum output power.</p> <p>⚠ CAUTION: Combining AC and DC PSUs is not supported and triggers a mismatch.</p>
E	Not lit	Power is not connected.

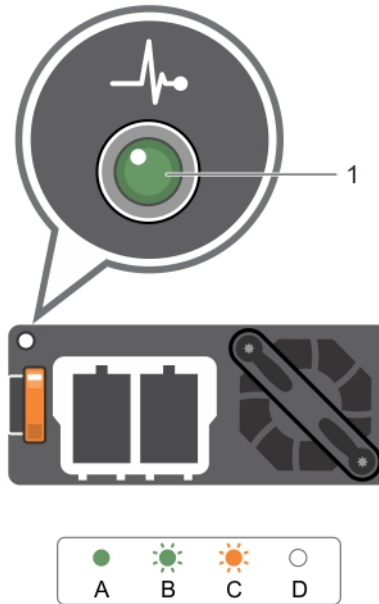

Figure 8. DC PSU status indicator

1 DC PSU status indicator

Table 8. DC PSU status indicators

Convention	Power indicator pattern	Condition
A	Green	A valid power source is connected to the PSU and that the PSU is operational.
B	Flashing green	When hot-adding a PSU, the PSU indicator flashes green. This indicates that there is a PSU mismatch with respect to efficiency, feature set, health status, and supported voltage. Ensure that both the PSUs are of the same capacity.
C	Flashing amber	Indicates a problem with the PSU. <p>⚠ CAUTION: When correcting a PSU mismatch, replace only the PSU with the flashing indicator. Swapping the PSU to make a matched pair can result in an error condition and unexpected system shutdown. To change from a High Output configuration to a Low Output configuration or vice versa, you must power down the system.</p> <p>⚠ CAUTION: AC PSU support both 220 V and 110 V input voltages with the exception of Titanium PSU, which support only 220 V. When two identical PSU receive different input voltages, they can output different wattages, and trigger a mismatch.</p>

Convention	Power indicator pattern	Condition
		<p>⚠ CAUTION: If two PSU are used, they must be of the same type and have the same maximum output power.</p> <p>⚠ CAUTION: Combining AC and DC PSU is not supported and triggers a mismatch.</p>
D	Not lit	Power is not connected.

Hard drive indicator codes

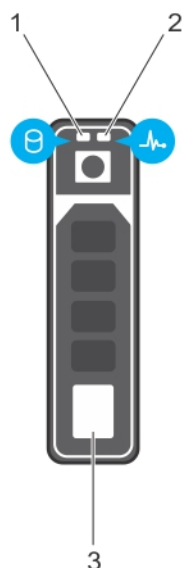

Figure 9. Hard drive indicators

- 1 hard drive activity indicator
- 2 hard drive status indicator
- 3 hard drive

NOTE: If the hard drive is in the Advanced Host Controller Interface (AHCI) mode, the status indicator (on the right side) does not function and remains off.

Table 9. Hard drive indicator codes

Drive-status indicator pattern (RAID only)	Condition
Flashes green twice per second	Identifying drive or preparing for removal.
Off	Drive ready for insertion or removal.
	<p>NOTE: The drive status indicator remains off until all hard drives are initialized after the system is turned on. Drives are not ready for insertion or removal during this time.</p>
Flashes green, amber, and turns off	Predicted drive failure
Flashes amber four times per second	Drive failed
Flashes green slowly	Drive rebuilding

Drive-status indicator pattern (RAID only)	Condition
Steady green	Drive online
Flashes green for three seconds, amber for three seconds, and turns off after six seconds	Rebuild stopped

Locating Service Tag of your system

Your system is identified by a unique Express Service Code and Service Tag number. The Express Service Code and Service Tag are found on the front of the system by pulling out the information tag. Alternatively, the information may be on a sticker on the chassis of the system. This information is used by Dell to route support calls to the appropriate personnel.

Converting the system from tower mode to rack mode

Your system can be converted from the tower mode to the rack mode.

To convert your system from the tower mode to the rack mode, you require the tower to rack conversion kit, which contains the following items:

- Rack ears (left and right) with three screws each
- VGA module
- Rack slide cover
- Mylar cover
- A pair of rails (optional)

Preparing a system for conversion from tower mode to rack mode

Prerequisites

- 1 Follow the safety guidelines listed in the Safety instructions section.
- 2 Keep the Phillips #2 screwdriver ready.
- 3 Turn off the system, including any attached peripherals, and disconnect the system from the electrical outlet and peripherals.
- 4 Lay the system on a flat, stable surface.
- 5 If installed, remove the system feet or caster wheels. For more information, see removing the system feet or removing caster wheels.
- 6 Remove the system cover.

Steps

- 1 Remove the system top cover. For more information, see the Removing system top cover section.
- 2 Remove the control-panel assembly. For more information, see the Removing control panel assembly section.
- 3 Install the rack slide cover by performing the following steps:
 - a Slide the rack slide cover between the system's side cover and the chassis.
 - b Slide the rack slide cover toward the back of the system until the tabs on rack slide cover locks with the tabs extending from the chassis.

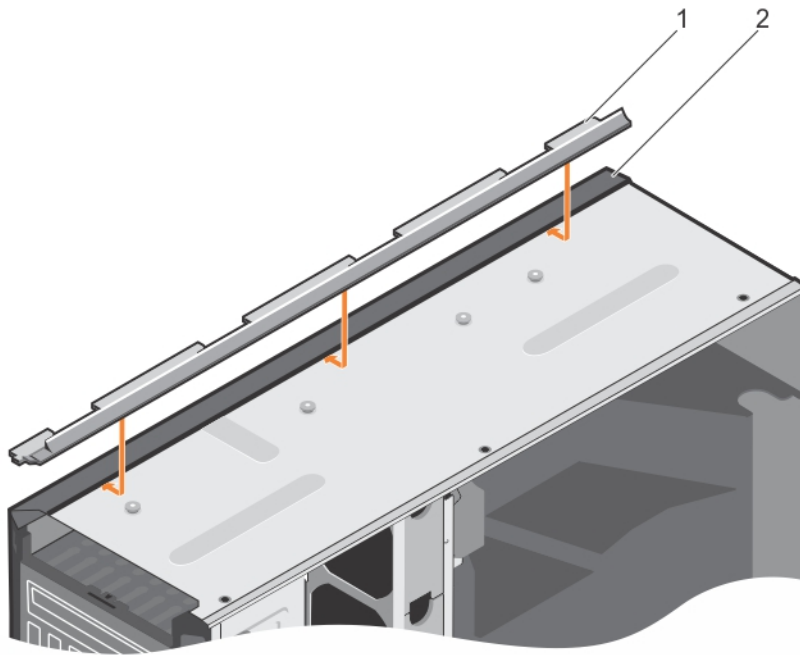

Figure 10. Installing the rack slide cover

1 rack slide cover

2 system chassis

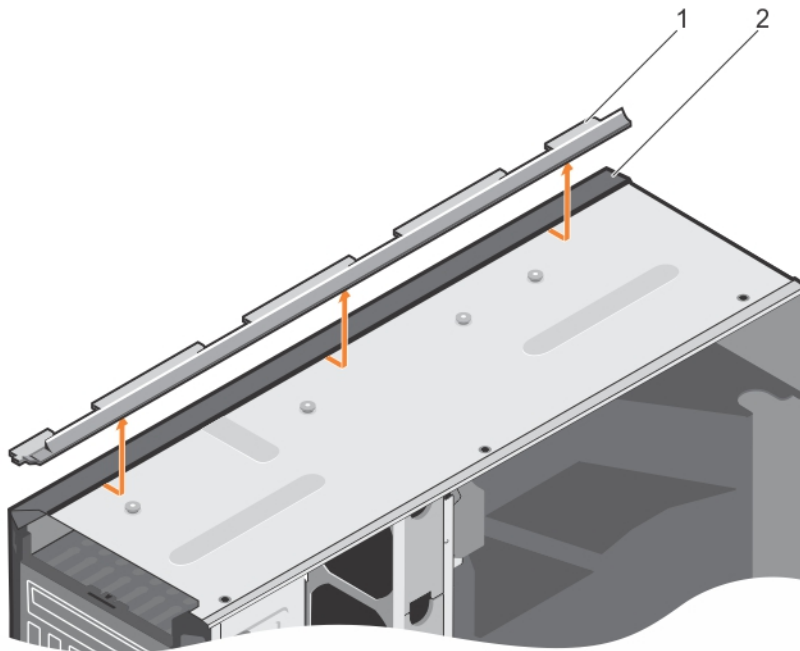

Figure 11. Removing the rack slide cover

1 rack slide cover

2 system chassis

- 4 Install the control panel assembly. For more information, see [Installing control panel assembly](#).
- 5 Attach the mylar to cover the openings on the chassis where the system rear feet were installed in the tower mode. See the following figure for more information.

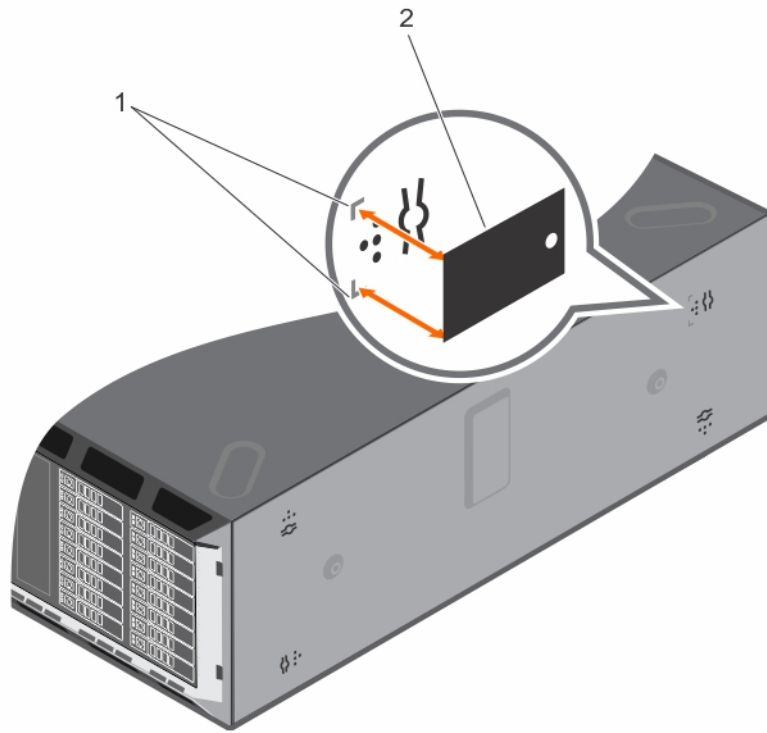

Figure 12. Attaching the mylar cover

1 marking on chassis

2 mylar cover

6 Install the system cover.

7 Install the rack ears by performing the following steps:

- a Align the three screw holes on the rack ears with the screw holes on the top and the bottom of system.
- b Install the three screws using a Phillips #2 screwdriver.

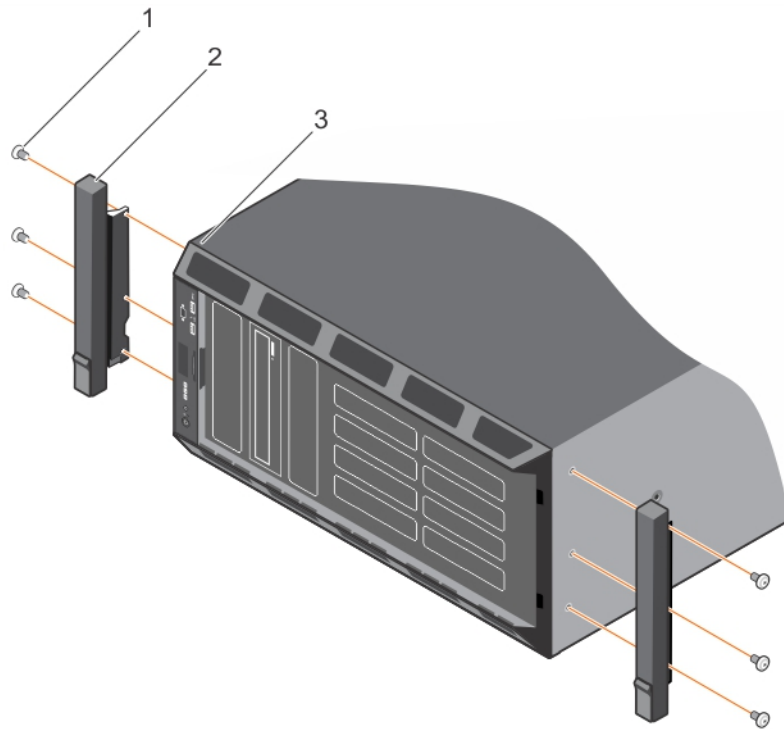

Figure 13. Removing the rack ears

- 1 screw (6)
- 3 system in rack mode

- 2 rack ear (2)

8 Install the system in the rack. For more information, see the Rack Installation Guide that is shipped with your system.

Related links

- [Safety instructions](#)
- [Removing the system cover](#)
- [Removing the control panel assembly](#)

Documentation resources

This section provides information about the documentation resources for your system.

Table 10. Documentation resources for system

Task	Document	Location
Setting up your system	For information about installing the system into a rack, see the Rack documentation included with your rack solution.	Dell.com/poweredgemanuals
	For information about turning on the system and the technical specifications of your system, see the <i>Getting Started With Your System</i> that shipped with your system.	Dell.com/poweredgemanuals
	For information about <i>Getting Started With Your System</i> that shipped with your system or the Technical specifications section in this document.	Dell.com/poweredgemanuals
Configuring your system	For information about iDRAC features, configuring and logging in to iDRAC, and managing your system remotely, see the Integrated Dell Remote Access Controller User's Guide.	Dell.com/idracmanuals
	For information about installing the operating system, see the operating system documentation.	Dell.com/operatingsystemmanuals
	For information about understanding Remote Access Controller Admin (RACADM) subcommands and supported RACADM interfaces, see the RACADM Command Line Reference Guide for iDRAC.	Dell.com/idracmanuals
	For information about updating drivers and firmware, see the Download firmware and drivers section in this document.	Dell.com/support/drivers
Managing your system	For information about the features of the Dell OpenManage Systems Management, see the Dell OpenManage Systems Management Overview Guide.	Dell.com/openmanagemanuals
	For information about setting up, using, and troubleshooting OpenManage, see the Dell OpenManage Server Administrator User's Guide.	Dell.com/openmanagemanuals
	For information about installing, using, and troubleshooting Dell OpenManage Essentials, see the Dell OpenManage Essentials User's Guide.	Dell.com/openmanagemanuals

Task	Document	Location
	For information about installing and using Dell System E-Support Tool (DSET), see the Dell System E-Support Tool (DSET) User's Guide.	Dell.com/DSET
	For information about installing and using Active System Manager (ASM), see the Active System Manager User's Guide.	Dell.com/asmdocs
	For understanding the features of Dell Lifecycle Controller (LCC), see the Dell Lifecycle Controller User's Guide.	Dell.com/idracmanuals
	For information about partner programs enterprise systems management, see the OpenManage Connections Enterprise Systems Management documents.	Dell.com/omconnectionsenterprisesystemsmanagement
	For information about connections and client systems management, see the OpenManage Connections Client Systems Management documentation.	Dell.com/dellclientcommandsuitemanuals
	For information about viewing inventory, performing configuration and monitoring tasks, remotely turning on or off servers, and enabling alerts for events on servers and components using the Dell Chassis Management Controller (CMC), see the CMC User's Guide.	Dell.com/esmmanuals
Working with Dell PowerEdge RAID controllers	For information about understanding the features of the Dell PowerEdge RAID controllers (PERC) and deploying the PERC cards, see the Storage controller documentation.	Dell.com/storagecontrollermanuals
Understanding event and error messages	For information about checking the event and error messages generated by the system firmware and agents that monitor system components, see the Dell Event and Error Messages Reference Guide.	Dell.com/openmanagemanuals > OpenManage software

Technical specifications

The technical and environmental specifications of your system are outlined in this section.

Chassis dimensions

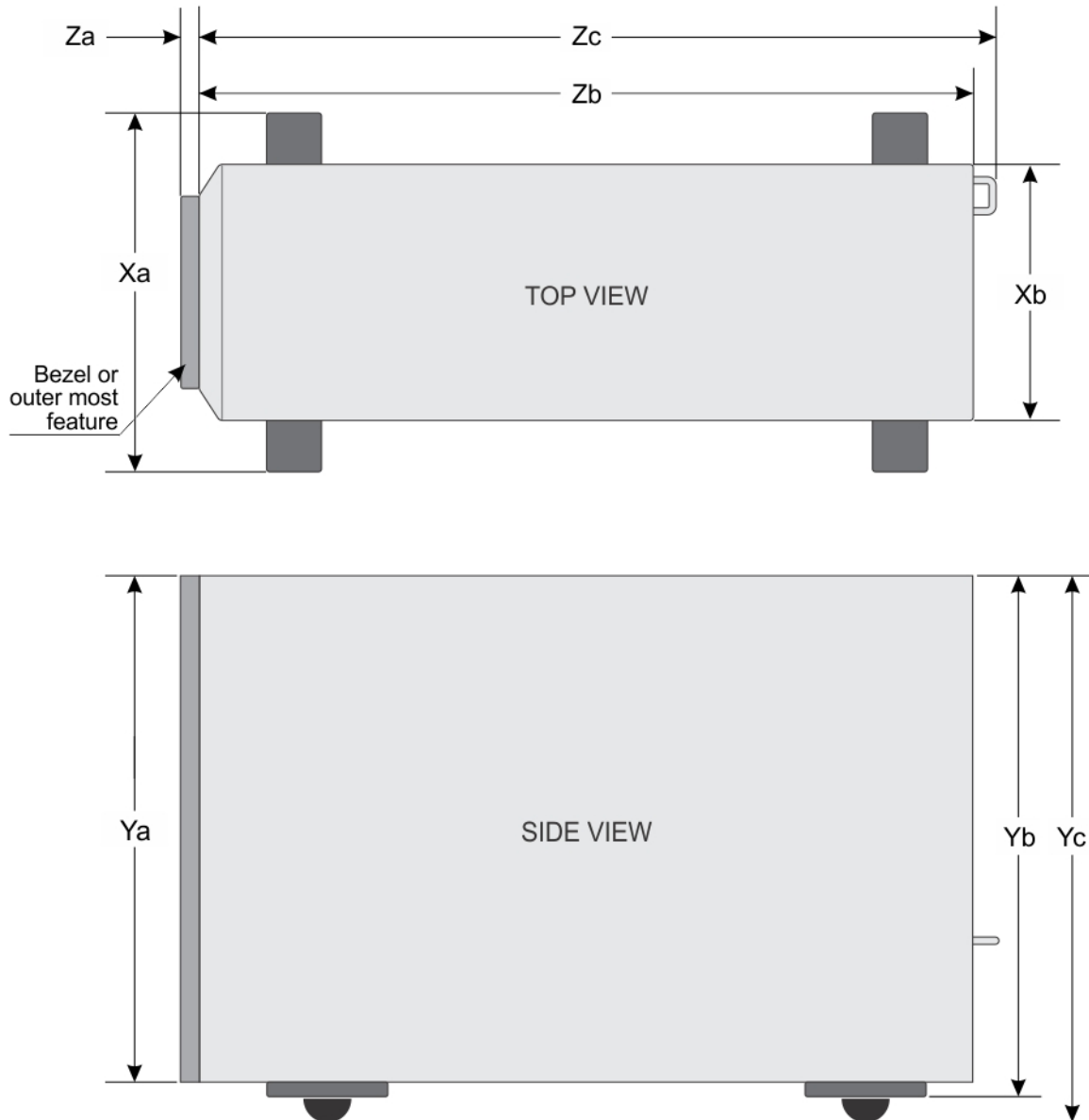

Figure 14. Details the dimensions of Dell PowerEdge T630 system

Table 11. The dimensions of Dell PowerEdge T630 system

System	Xa	Xb	Ya	Yb	Yc	Za with bezel	Za without bezel	Zb*	Zc
PowerEdge T630	304.5	217.9	434.5	443.5	471.5	15.9	0.0	659.9	692.8

Chassis weight

Table 12. Chassis weight

PowerEdge T630	Maximum weight
3.5 inch hard-drive chassis	49.65 kg
2.5 inch hard-drive chassis	42.36 kg

Processor specifications

The PowerEdge T630 system supports up to two Intel Xeon E5-2600 v4 or Xeon E5-2600 v3 product family processors.

PSU specifications

The PowerEdge T630 system supports up to two AC or DC redundant power supply units (PSUs).

Table 13. PSU specifications

PSU	Class	Heat dissipation (maximum)	Frequency	Voltage
495 W AC	Platinum	1908 BTU/hr	50/60 Hz	100–240 V AC, autoranging
750 W AC	Platinum	2891 BTU/hr		
	Titanium	2843 BTU/hr		200–240 V AC, autoranging
1100 W AC	Platinum	4100 BTU/hr		100–240 V AC, autoranging
1600 W AC	Platinum	6000 BTU/hr		100–240 V AC, autoranging
1100 W DC (for China only)	NA	4416 BTU/hr		–(48–60) V DC

NOTE: Heat dissipation is calculated using the PSU wattage rating.

NOTE: This system is also designed to connect to the IT power systems with a phase to phase voltage not exceeding 230 V.

NOTE: PSUs rated for 1600 W and higher require high-line voltage (200-240 V) to supply their rated capacity.

System battery specifications

The PowerEdge T630 system supports CR 2032 3.0-V lithium coin cell system battery.

Expansion bus specifications

The PowerEdge T630 system supports PCI express (PCIe) generation 3 and 2 expansion cards. The following table describes the supported expansion cards:

Table 14. Supported PCI express generation 3 expansion cards

PCIe Slot	Processor Connection	Height	Length	Link Width	Slot Width
1 (Gen3)	Processor 1	Standard Height	Full Length	x16	x16
2 (Gen2)	Platform Controller Hub	Standard Height	Full Length*	x4	x8
3 (Gen3)	Processor 1	Standard Height	Full Length	x16	x16
4 (Gen3)	Processor 2	Standard Height	Half Length	x8	x8
5 (Gen2)	Processor 2	Standard Height	Full Length*	x4	x8
6 (Gen3)	Processor 2	Standard Height	Full Length	x16	x16
7 (Gen3)	Processor 2	Standard Height	Full Length	x16	x16
8 (Internal PERC Slot)	Processor 1	Standard Height	Half Length	x8	x8

*PCIe Generation 2 expansion card.

NOTE: To use PCIe slots 4, 5, 6, and 7, both the processors must be installed.

NOTE: The expansion card slots are not hot-swappable.

Memory specifications

The PowerEdge T630 system supports 1866 MT/s, 2133 MT/s or 2400 MT/s DDR4 Registered or Load-Reduced Error Correcting Code (ECC) DIMMs support for advanced ECC or memory optimized operation.

Table 15. Memory specifications

Memory module sockets	Memory capacity	Minimum RAM	Maximum RAM
Twenty-four 288-pin	<ul style="list-style-type: none"> 64 GB quad rank (LRDIMMs) 4 GB single rank (RDIMMs) 8 GB or 16 GB dual rank (RDIMMs) 	<ul style="list-style-type: none"> 4 GB with single processor 8 GB with dual processors (minimum one memory module per processor) 	<ul style="list-style-type: none"> Up to 768 GB with a single processor Up to 1536 GB with dual processors

Drive specifications

Hard drives

The PowerEdge T630 system supports:

- Up to eight 3.5 inch, internal, hot-swappable SAS, SATA, SSD, or Nearline SAS hard drives or Up to eight 2.5 inch, internal, hot-swappable SAS, SATA, SSD, or Nearline SAS hard drives in a 3.5 inch hard-drive carrier. Hard-drive slots 0 through 3 and 4 through 7.
- Up to eight 3.5 inch, internal, hot-swappable SAS, SATA, SSD, or Nearline SAS hard drives and four Dell PowerEdge Express Flash devices (PCIe SSDs) . Hard-drive slots 0 through 7 and 0 through 3

- Up to eighteen 3.5 inch, internal, hot-swappable SAS, SATA, SSD, or Nearline SAS hard drives. Hard-drive slots 0 through 5, 6 through 11, and 12 through 17.
- Up to sixteen 2.5 inch, internal, hot-swappable SAS, SATA, SSD, or Nearline SAS hard drives. Hard-drive slots 0 through 7 and 8 through 15.
- Up to thirty-two 2.5 inch, internal, hot-swappable SAS, SATA, SSD, or Nearline SAS hard drives Hard-drive slots 0 through 7, 8 through 15, 16 through 23, and 24 through 31.
- Up to thirty-two 2.5 inch, internal, hot-swappable SAS, SATA, SATA SSD, or Nearline SAS hard drives. Hard-drive slots 0 through 7, 8 through 15, 0 through 7, and 8 through 15.

Optical drive

The PowerEdge T630 system supports one optional SATA DVD-ROM drive or DVD+/-RW drive or One optional slim SATA DVD-ROM drive or DVD +/-RW drive.

NOTE: DVD devices are data only.

Ports and connectors specifications

Serial connector

The serial connector connects a serial device to the system. The PowerEdge T630 system supports DB-9 Serial Port connector.

Internal Dual SD Module

The PowerEdge RT630 system supports two optional flash memory card slots with an internal SD module.

NOTE: One card slot is dedicated for redundancy.

VGA ports

The Video Graphic Array (VGA) port enables you to connect the system to a VGA display. The PowerEdge T630 system supports two 15-pin VGA ports on the front and back panels.

NOTE: The front VGA port is available only with the rack configuration.

USB ports

The PowerEdge T630 system supports:

- USB 2.0-compliant ports and USB 3.0-complaint ports on the front and back panel
- Internal USB 3.0-compliant port

The following table provides more information about the USB specifications:

Table 16. USB specifications

System	Front panel	Back panel	Internal
PowerEdge T630	<ul style="list-style-type: none"> Two Hi-Speed USB Host One USB 2.0-compliant ports and one USB 3.0-complaint ports 	<ul style="list-style-type: none"> Six Hi-Speed USB Host Four USB 2.0 compliant ports Two USB 3.0-complaint ports 	One 4-pin, USB 3.0-compliant port

NIC ports

The PowerEdge T630 system supports four Network Interface Controller (NIC) ports on the back panel, which is available in the following NIC configurations:

- Two 10/100/1000 Mbps

Video specifications

The PowerEdge T630 system supports Integrated Matrox G200 with iDRAC8 and 16 MB application memory.

Table 17. Supported video resolution options

Resolution	Refresh Rate (Hz)	Color Depth (bit)
640 x 480	60, 70	8, 16, 32
800 x 600	60, 75, 85	8, 16, 32
1024 x 768	60, 75, 85	8, 16, 32
1280 x 1024	60	8, 16, 32
1440 x 900 (stretch goal)	60	8, 16, 32

Environmental specifications

NOTE: For additional information about environmental measurements for specific system configurations, see Dell.com/environmental_datasheets.

Table 18. Temperature specifications

Temperature	Specifications
Storage	-40°C to 65°C (-40°F to 149°F)
Continuous operation (for altitude less than 950 m or 3117 ft)	10°C to 35°C (50°F to 95°F) with no direct sunlight on the equipment.
Fresh air	For information about fresh air, see Expanded Operating Temperature section.
Maximum temperature gradient (operating and storage)	20°C/h (68°F/h)

Table 19. Relative humidity specifications

Relative humidity	Specifications
Storage	5% to 95% RH with 33°C (91°F) maximum dew point. Atmosphere must be non-condensing at all times.
Operating	10% to 80% relative humidity with 29°C (84.2°F) maximum dew point.

Table 20. Maximum vibration specifications

Maximum vibration	Specifications
Operating	0.26 G _{rms} at 5 Hz to 350 Hz (all operation orientations).
Storage	1.88 G _{rms} at 10 Hz to 500 Hz for 15 min (all six sides tested).

Table 21. Maximum shock specifications

Maximum vibration	Specifications
Operating	Six consecutively executed shock pulses in the positive and negative x, y, and z axes of 40 G for up to 2.3 ms.
Storage	Six consecutively executed shock pulses in the positive and negative x, y, and z axes (one pulse on each side of the system) of 71 G for up to 2 ms.

Table 22. Maximum altitude specifications

Maximum altitude	Specifications
Operating	3048 m (10,000 ft)
Storage	12,000 m (39,370 ft)

Table 23. Operating temperature de-rating specifications

Operating temperature de-rating	Specifications
Up to 35°C (95°F)	Maximum temperature is reduced by 1°C/300 m (1°F/547 ft) above 950 m (3,117 ft).
35°C to 40°C (95°F to 104°F)	Maximum temperature is reduced by 1°C/175 m (1°F/319 ft) above 950 m (3,117 ft).
40°C to 45°C (104°F to 113°F)	Maximum temperature is reduced by 1°C/125 m (1°F/228 ft) above 950 m (3,117 ft).

Particulate and gaseous contamination specifications

The following table defines the limitations that help avoid any equipment damage or failure from particulates and gaseous contamination. If the levels of particulates or gaseous pollution exceed the specified limitations and result in equipment damage or failure, you may need to rectify the environmental conditions. Re-mediation of environmental conditions is the responsibility of the customer.

Table 24. Particulate contamination specifications

Particulate contamination	Specifications
Air filtration	<p>Data center air filtration as defined by ISO Class 8 per ISO 14644-1 with a 95% upper confidence limit.</p> <p>NOTE: This condition applies to data center environments only. Air filtration requirements do not apply to IT equipment designed to be used outside a data center, in environments such as an office or factory floor.</p> <p>NOTE: Air entering the data center must have MERV11 or MERV13 filtration.</p>
Conductive dust	<p>Air must be free of conductive dust, zinc whiskers, or other conductive particles.</p> <p>NOTE: This condition applies to data center and non-data center environments.</p>
Corrosive dust	<ul style="list-style-type: none"> Air must be free of corrosive dust. Residual dust present in the air must have a deliquescent point less than 60% relative humidity. <p>NOTE: This condition applies to data center and non-data center environments.</p>

Table 25. Gaseous contamination specifications

Gaseous contamination	Specifications
Copper coupon corrosion rate	<300 Å/month per Class G1 as defined by ANSI/ISA71.04-1985.
Silver coupon corrosion rate	<200 Å/month as defined by AHSRAE TC9.9.

NOTE: Maximum corrosive contaminant levels measured at ≤50% relative humidity.

Expanded operating temperature

Table 26. Expanded operating temperature specifications

Expanded operating temperature	Specifications
Continuous operation	<p>5°C to 40°C at 5% to 85% RH with 29°C dew point.</p> <p>NOTE: Outside the standard operating temperature (10°C to 35°C), the system can operate continuously in temperatures as low as 5°C and as high as 40°C.</p> <p>For temperatures between 35°C and 40°C, de-rate maximum allowable temperature by 1°C per 175 m above 950 m (1°F per 319 ft).</p>
≤ 1% of annual operating hours	–5°C to 45°C at 5% to 90% RH with 29°C dew point.

NOTE: Outside the standard operating temperature (10°C to 35°C), the system can operate down to –5°C or up to 45°C for a maximum of 1% of its annual operating hours.

For temperatures between 40°C and 45°C, de-rate maximum allowable temperature by 1°C per 125 m above 950 m (1°F per 228 ft).

NOTE: When operating in the expanded temperature range, system performance may be impacted.

NOTE: When operating in the expanded temperature range, ambient temperature warnings may be reported on the LCD panel and in the System Event Log.

Expanded operating temperature restrictions

- Do not perform a cold startup below 5°C.
- You must have six fans configured on your system.
- The operating temperature specified is for a maximum altitude of 3048 m (10,000 ft)
- Express Flash is not supported.
- GPU is not supported.
- 160 W workstation CPU is not supported.
- Internal TBU (Tape Backup Unit) is not supported.
- Two power supplies in redundant mode are required, but do not support PSU failure function.
- Non Dell qualified peripheral cards and/or peripheral cards greater than 25 W are not supported.
- PCIe SSD is not supported
- Eighteen 3.5 inch hard-drive configuration is not supported
- Fusion IO is not supported.

Initial system setup and configuration

Setting up your system

Complete the following steps to set up your system:

- 1 Unpack the system.
- 2 Install the system into the rack. For more information about installing the system into the rack, see your system *Rack Installation Placemat* at [Dell.com/poweredge/manuals](https://www.dell.com/poweredge/manuals).
- 3 Connect the peripherals to the system.
- 4 Connect the system to its electrical outlet.
- 5 Turn the system on by pressing the power button or by using iDRAC.
- 6 Turn on the attached peripherals.

iDRAC configuration

The Integrated Dell Remote Access Controller (iDRAC) is designed to make system administrators more productive and improve the overall availability of Dell systems. iDRAC alerts administrators to system issues, helps them perform remote system management, and reduces the need for physical access to the system.

Options to set up iDRAC IP address

You must configure the initial network settings based on your network infrastructure to enable the communication to and from iDRAC. You can set up the IP address by using one of the following interfaces:

Interfaces	Document/Section
iDRAC Settings utility	See <i>Dell Integrated Dell Remote Access Controller User's Guide</i> at Dell.com/idrac/manuals
Dell Deployment Toolkit	See <i>Dell Deployment Toolkit User's Guide</i> at Dell.com/openmanagement/manuals
Dell Lifecycle Controller	See <i>Dell Lifecycle Controller User's Guide</i> at Dell.com/idrac/manuals
Chassis or Server LCD panel	See the LCD panel section

You must use the default iDRAC IP address 192.168.0.120 to configure the initial network settings, including setting up DHCP or a static IP for iDRAC.

- NOTE:** To access iDRAC, ensure that you install the iDRAC port card or connect the network cable to the Ethernet connector 1 on the system board.
- NOTE:** Ensure that you change the default user name and password after setting up the iDRAC IP address.

Log in to iDRAC

You can log in to iDRAC as:

- iDRAC user
- Microsoft Active Directory user
- Lightweight Directory Access Protocol (LDAP) user

The default user name and password are `root` and `calvin`. You can also log in by using Single Sign-On or Smart Card.

NOTE: You must have iDRAC credentials to log in to iDRAC.

For more information about logging in to iDRAC and iDRAC licenses, see the *Integrated Dell Remote Access Controller User's Guide* at [Dell.com/idracmanuals](https://www.dell.com/support/manuals).

Options to install the operating system

If the system is shipped without an operating system, install the supported operating system by using one of the following resources:

Table 27. Resources to install the operating system

Resources	Location
Dell Systems Management Tools and Documentation media	Dell.com/operatingsystemmanuals
Dell Lifecycle Controller	Dell.com/idracmanuals
Dell OpenManage Deployment Toolkit	Dell.com/openmanagemanuals
Dell certified VMware ESXi	Dell.com/virtualizationsolutions
Supported operating systems on Dell PowerEdge systems	Dell.com/ossupport
Installation and How-to videos for supported operating systems on Dell PowerEdge systems	Supported Operating Systems for Dell PowerEdge Systems

Downloading the drivers and firmware

Dell recommends that you download and install the latest BIOS, drivers, and systems management firmware on your system.

Prerequisite

Ensure that you clear the web browser cache before downloading the drivers and firmware.

Steps

- 1 Go to [Dell.com/support/drivers](https://www.dell.com/support/drivers).
- 2 Under the **Drivers & Downloads** section, type the Service Tag of your system in the **Service Tag or Express Service Code** box.

NOTE: If you do not have the Service Tag, select **Detect My Product** to allow the system to automatically detect your Service Tag, or under **General support**, navigate to your product.

- 3 Click **Drivers & Downloads**.
The drivers that are applicable to your selection are displayed.
- 4 Download the drivers you need to a USB drive, CD, or DVD.

Pre-operating system management applications

You can manage basic settings and features of a system without booting to the operating system by using the system firmware.

Options to manage the pre-operating system applications

Your system has the following options to manage the pre-operating system applications:

- System Setup
- Boot Manager
- Dell Lifecycle Controller
- Preboot Execution Environment (PXE)

Related links

- [System Setup](#)
- [Boot Manager](#)
- [Dell Lifecycle Controller](#)
- [PXE boot](#)

System Setup

By using the **System Setup** screen, you can configure the BIOS settings, iDRAC settings, and device settings of your system.

NOTE: Help text for the selected field is displayed in the graphical browser by default. To view the help text in the text browser, press F1.

You can access system setup by using two methods:

- Standard graphical browser—The browser is enabled by default.
- Text browser—The browser is enabled by using Console Redirection.

Related links

- [System Setup details](#)
- [Viewing System Setup](#)

Viewing System Setup

To view the **System Setup** screen, perform the following steps:

- 1 Turn on, or restart your system.
- 2 Press F2 immediately after you see the following message:

F2 = System Setup

NOTE: If your operating system begins to load before you press F2, wait for the system to finish booting, and then restart your system and try again.

Related links

- [System Setup](#)
- [System Setup details](#)

System Setup details

The **System Setup Main Menu** screen details are explained as follows:

Option	Description
System BIOS	Enables you to configure BIOS settings.
iDRAC Settings	Enables you to configure iDRAC settings. The iDRAC settings utility is an interface to set up and configure the iDRAC parameters by using UEFI (Unified Extensible Firmware Interface). You can enable or disable various iDRAC parameters by using the iDRAC settings utility. For more information about this utility, see <i>Integrated Dell Remote Access Controller User's Guide</i> at Dell.com/idracmanuals .
Device Settings	Enables you to configure device settings.

Related links

- [System BIOS Settings details](#)
- [Device Settings](#)

System BIOS

You can use the **System BIOS** screen to edit specific functions such as boot order, system password, setup password, set the RAID mode, and enable or disable USB ports.

Related links

- [System BIOS Settings details](#)
- [Boot Settings](#)
- [System Information](#)
- [Memory Settings](#)
- [Processor Settings](#)
- [SATA Settings](#)
- [Integrated Devices](#)
- [Serial Communication](#)
- [System Profile Settings](#)
- [Miscellaneous Settings](#)
- [iDRAC Settings utility](#)
- [Device Settings](#)
- [System Security Settings details](#)
- [Viewing System BIOS](#)

Viewing System BIOS

To view the **System BIOS** screen, perform the following steps:

- 1 Turn on, or restart your system.
- 2 Press F2 immediately after you see the following message:

F2 = System Setup

NOTE: If your operating system begins to load before you press F2, wait for the system to finish booting, and then restart your system and try again.

- 3 On the **System Setup Main Menu** screen, click **System BIOS**.

Related links

[System BIOS](#)

[System BIOS Settings details](#)

System BIOS Settings details

The **System BIOS Settings** screen details are explained as follows:

Option	Description
System Information	Specifies information about the system such as the system model name, BIOS version, and Service Tag.
Memory Settings	Specifies information and options related to the installed memory.
Processor Settings	Specifies information and options related to the processor such as speed and cache size.
Boot Settings	Specifies options to specify the boot mode (BIOS or UEFI). Enables you to modify UEFI and BIOS boot settings.
Network Settings	Specifies options to change the network settings.
Integrated Devices	Specifies options to manage integrated device controllers and ports and specify related features and options.
Serial Communication	Specifies options to manage the serial ports and specify related features and options.
System Profile Settings	Specifies options to change the processor power management settings, memory frequency, and so on.
System Security	Specifies options to configure the system security settings, such as system password, setup password, Trusted Platform Module (TPM) security. It also manages the power and NMI buttons on the system.
Miscellaneous Settings	Specifies options to change the system date, time, and so on.

Related links

[System BIOS](#)

[Viewing System BIOS](#)

Boot Settings

You can use the **Boot Settings** screen to set the boot mode to either **BIOS** or **UEFI**. It also enables you to specify the boot order.

Related links

- [Boot Settings details](#)
- [System BIOS](#)
- [Viewing Boot Settings](#)
- [Choosing the system boot mode](#)
- [Changing the boot order](#)

Viewing Boot Settings

To view the **Boot Settings** screen, perform the following steps:

- 1 Turn on, or restart your system.
- 2 Press F2 immediately after you see the following message:

F2 = System Setup

NOTE: If your operating system begins to load before you press F2, wait for the system to finish booting, and then restart your system and try again.

- 3 On the **System Setup Main Menu** screen, click **System BIOS**.
- 4 On the **System BIOS** screen, click **Boot Settings**.

Related links

- [Boot Settings](#)
- [Boot Settings details](#)
- [Choosing the system boot mode](#)
- [Changing the boot order](#)

Boot Settings details

The **Boot Settings** screen details are explained as follows:

Option	Description
Boot Mode	<p>Enables you to set the boot mode of the system.</p> <p>CAUTION: Switching the boot mode may prevent the system from booting if the operating system is not installed in the same boot mode.</p> <p>If the operating system supports UEFI, you can set this option to UEFI. Setting this field to BIOS allows compatibility with non-UEFI operating systems. This option is set to BIOS by default.</p> <p>NOTE: Setting this field to UEFI disables the BIOS Boot Settings menu. Setting this field to BIOS disables the UEFI Boot Settings menu.</p>
Boot Sequence Retry	<p>Enables or disables the Boot Sequence Retry feature. If this option is set to Enabled and the system fails to boot, the system reattempts the boot sequence after 30 seconds. This option is set to Enabled by default.</p>
Hard-Disk Failover	<p>Specifies the hard drive that is booted in the event of a hard drive failure. The devices are selected in the Hard-Disk Drive Sequence on the Boot Option Setting menu. When this option is set to Disabled, only the first hard drive in the list is attempted to boot. When this option is set to Enabled, all hard drives are attempted to boot in the order selected in the Hard-Disk Drive Sequence. This option is not enabled for UEFI Boot Mode.</p>
BIOS Boot Settings	<p>Enables or disables BIOS boot options.</p> <p>NOTE: This option is enabled only if the boot mode is BIOS.</p>
UEFI Boot Settings	<p>Enables or disables UEFI Boot options. The Boot options include IPv4 PXE and IPv6 PXE. This option is set to IPv4 by default.</p> <p>NOTE: This option is enabled only if the boot mode is UEFI.</p>

Related links

- [Boot Settings](#)
- [Viewing Boot Settings](#)
- [Choosing the system boot mode](#)
- [Changing the boot order](#)

Choosing the system boot mode

System Setup enables you to specify one of the following boot modes for installing your operating system:

- BIOS boot mode (the default) is the standard BIOS-level boot interface.
- Unified Extensible Firmware Interface (UEFI) boot mode is an enhanced 64-bit boot interface. If you have configured your system to boot to UEFI mode, it replaces the system BIOS.

- 1 From the **System Setup Main Menu**, click **Boot Settings**, and select **Boot Mode**.
- 2 Select the boot mode you want the system to boot into.

 **CAUTION:** Switching the boot mode may prevent the system from booting if the operating system is not installed in the same boot mode.

- 3 After the system boots in the specified boot mode, proceed to install your operating system from that mode.

 **NOTE:** Operating systems must be UEFI-compatible to be installed from the UEFI boot mode. DOS and 32-bit operating systems do not support UEFI and can only be installed from the BIOS boot mode.

 **NOTE:** For the latest information about supported operating systems, go to Dell.com/ossupport.

Related links

- [Boot Settings](#)
- [Boot Settings details](#)
- [Viewing Boot Settings](#)

Changing the boot order

You may have to change the boot order if you want to boot from a USB key or an optical drive. The following instructions may vary if you have selected **BIOS** for **Boot Mode**.

- 1 On the **System Setup Main Menu** screen, click **System BIOS > Boot Settings**.
- 2 Click **BIOS/UEFI Boot Settings > Boot Sequence**.
- 3 Use the arrow keys to select a boot device, and use the plus (+) and minus (-) sign keys to move the device down or up in the order.
- 4 Click **Exit**, and then click **Yes** to save the settings on exit.

Related links

- [Boot Settings](#)
- [Boot Settings details](#)
- [Viewing Boot Settings](#)

System Security

You can use the **System Security** screen to perform specific functions such as setting the system password, setup password and disabling the power button.

Related links

- [System Security Settings details](#)
- [Operating with a setup password enabled](#)
- [System BIOS](#)
- [Viewing System Security](#)
- [Creating a system and setup password](#)
- [Using your system password to secure your system](#)
- [Deleting or changing system and setup password](#)

Viewing System Security

To view the **System Security** screen, perform the following steps:

- 1 Turn on, or restart your system.
- 2 Press F2 immediately after you see the following message:

F2 = System Setup

NOTE: If your operating system begins to load before you press F2, wait for the system to finish booting, and then restart your system and try again.

- 3 On the **System Setup Main Menu** screen, click **System BIOS**.
- 4 On the **System BIOS** screen, click **System Security**.

Related links

- [System Security](#)
- [System Security Settings details](#)

System Security Settings details

The **System Security Settings** screen details are explained as follows:

Option	Description
Intel AES-NI	Improves the speed of applications by performing encryption and decryption by using the Advanced Encryption Standard Instruction Set (AES-NI). This option is set to Enabled by default.
System Password	Sets the system password. This option is set to Enabled by default and is read-only if the password jumper is not installed in the system.
Setup Password	Sets the setup password. This option is read-only if the password jumper is not installed in the system.
Password Status	Locks the system password. This option is set to Unlocked by default.
TPM Security	NOTE: The TPM menu is available only when the TPM module is installed. Enables you to control the reporting mode of the TPM. The TPM Security option is set to Off by default. You can only modify the TPM Status, TPM Activation, and Intel TXT fields if the TPM Status field is set to either On with Pre-boot Measurements or On without Pre-boot Measurements .
TPM Information	Changes the operational state of the TPM. This option is set to No Change by default.
TPM Status	Specifies the TPM status.

Option	Description
TPM Command	<p> CAUTION: Clearing the TPM results in the loss of all keys in the TPM. The loss of TPM keys may affect booting to the operating system.</p> <p>Clears all the contents of the TPM. The TPM Clear option is set to No by default.</p>
Intel TXT	Enables or disables the Intel Trusted Execution Technology (TXT) option. To enable the Intel TXT option, virtualization technology and TPM Security must be enabled with Pre-boot measurements. This option is set to Off by default.
Power Button	Enables or disables the power button on the front of the system. This option is set to Enabled by default.
NMI Button	Enables or disables the NMI button on the front of the system. This option is set to Disabled by default.
AC Power Recovery	Sets how the system behaves after AC power is restored to the system. This option is set to Last by default.
AC Power Recovery Delay	Sets the time delay for the system to power up after AC power is restored to the system. This option is set to Immediate by default.
User Defined Delay (60s to 240s)	Sets the User Defined Delay option when the User Defined option for AC Power Recovery Delay is selected.
UEFI Variable Access	Provides varying degrees of securing UEFI variables. When set to Standard (the default), UEFI variables are accessible in the operating system per the UEFI specification. When set to Controlled , selected UEFI variables are protected in the environment and new UEFI boot entries are forced to be at the end of the current boot order.
Secure Boot	Enables Secure Boot, where the BIOS authenticates each pre-boot image by using the certificates in the Secure Boot Policy. Secure Boot is disabled by default.
Secure Boot Policy	When Secure Boot policy is set to Standard , the BIOS uses the system manufacturer's key and certificates to authenticate pre-boot images. When Secure Boot policy is set to Custom , the BIOS uses the user-defined key and certificates. Secure Boot policy is set to Standard by default.
Secure Boot Policy Summary	Specifies the list of certificates and hashes that secure boot uses to authenticate images.

Related links

- [System Security](#)
- [Viewing System Security](#)

Secure Boot Custom Policy Settings

Secure Boot Custom Policy Settings is displayed only when **Secure Boot Policy** is set to **Custom**.

Viewing Secure Boot Custom Policy Settings

To view the **Secure Boot Custom Policy Settings** screen, perform the following steps:

- 1 Turn on, or restart your system.
- 2 Press F2 immediately after you see the following message:

F2 = System Setup

 **NOTE:** If your operating system begins to load before you press F2, wait for the system to finish booting, and then restart your system and try again.

- 3 On the **System Setup Main Menu** screen, click **System BIOS**.
- 4 On the **System BIOS** screen, click **System Security**.
- 5 On the **System Security** screen, click **Secure Boot Custom Policy Settings**.

Secure Boot Custom Policy Settings details

The **Secure Boot Custom Policy Settings** screen details are explained as follows:

Option	Description
Platform Key	Imports, exports, deletes, or restores the platform key (PK).
Key Exchange Key Database	Enables you to import, export, delete, or restore entries in the Key Exchange Key (KEK) Database.
Authorized Signature Database	Imports, exports, deletes, or restores entries in the Authorized Signature Database (db).
Forbidden Signature Database	Imports, exports, deletes, or restores entries in the Forbidden Signature Database (dbx).

System Information

You can use the **System Information** screen to view system properties such as Service Tag, system model name, and the BIOS version.

Related links

- [System Information details](#)
- [System BIOS](#)
- [Viewing System Information](#)

Viewing System Information

To view the **System Information** screen, perform the following steps:

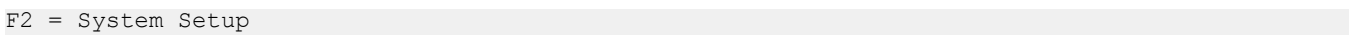
- 1 Turn on, or restart your system.
- 2 Press F2 immediately after you see the following message:

- 3 On the **System Setup Main Menu** screen, click **System BIOS**.
- 4 On the **System BIOS** screen, click **System Information**.

 **NOTE: If your operating system begins to load before you press F2, wait for the system to finish booting, and then restart your system and try again.**

Related link

- [System Information](#)

System Information details

The **System Information** screen details are explained as follows:

Option	Description
System Model Name	Specifies the system model name.
System BIOS Version	Specifies the BIOS version installed on the system.
System Management Engine Version	Specifies the current version of the Management Engine firmware.
System Service Tag	Specifies the system Service Tag.

Option	Description
System Manufacturer	Specifies the name of the system manufacturer.
System Manufacturer Contact Information	Specifies the contact information of the system manufacturer.
System CPLD Version	Specifies the current version of the system complex programmable logic device (CPLD) firmware.
UEFI Compliance Version	Specifies the UEFI compliance level of the system firmware.

Related links

- [System Information](#)
- [System Information details](#)
- [Viewing System Information](#)

Creating a system and setup password

Prerequisite

Ensure that the password jumper is enabled. The password jumper enables or disables the system password and setup password features. For more information, see the System board jumper settings section.

NOTE: If the password jumper setting is disabled, the existing system password and setup password are deleted and you need not provide the system password to boot the system.

Steps

- 1 To enter System Setup, press F2 immediately after turning on or rebooting your system.
- 2 On the **System Setup Main Menu** screen, click **System BIOS > System Security**.
- 3 On the **System Security** screen, verify that **Password Status** is set to **Unlocked**.
- 4 In the **System Password** field, type your system password, and press Enter or Tab.

Use the following guidelines to assign the system password:

 - A password can have up to 32 characters.
 - The password can contain the numbers 0 through 9.
 - Only the following special characters are allowed: space, ("), (+), (,), (-), (.), (/), (;), ([), (\), (]), (`).

A message prompts you to reenter the system password.
- 5 Reenter the system password, and click **OK**.
- 6 In the **Setup Password** field, type your setup password and press Enter or Tab.

A message prompts you to reenter the setup password.
- 7 Reenter the setup password, and click **OK**.
- 8 Press Esc to return to the System BIOS screen. Press Esc again.

A message prompts you to save the changes.

NOTE: Password protection does not take effect until the system reboots.

Related links

- [System board jumper settings](#)
- [System Security Settings details](#)
- [System Security](#)

Using your system password to secure your system

If you have assigned a setup password, the system accepts your setup password as an alternate system password.

Steps

- 1 Turn on or reboot your system.
- 2 Type the system password and press Enter.

Next step

When **Password Status** is set to **Locked**, type the system password and press Enter when prompted at reboot.

NOTE: If an incorrect system password is typed, the system displays a message and prompts you to reenter your password. You have three attempts to type the correct password. After the third unsuccessful attempt, the system displays an error message that the system has stopped functioning and must be turned off. Even after you turn off and restart the system, the error message is displayed until the correct password is entered.

Related link

[System Security](#)

Deleting or changing system and setup password

Prerequisite

NOTE: You cannot delete or change an existing system or setup password if the **Password Status** is set to **Locked**.

Steps

- 1 To enter System Setup, press F2 immediately after turning on or restarting your system.
- 2 On the **System Setup Main Menu** screen, click **System BIOS > System Security**.
- 3 On the **System Security** screen, ensure that **Password Status** is set to **Unlocked**.
- 4 In the **System Password** field, alter or delete the existing system password, and then press Enter or Tab.
- 5 In the **Setup Password** field, alter or delete the existing setup password, and then press Enter or Tab.
If you change the system and setup password, a message prompts you to reenter the new password. If you delete the system and setup password, a message prompts you to confirm the deletion.
- 6 Press Esc to return to the **System BIOS** screen. Press Esc again, and a message prompts you to save the changes.

Related link

[System Security](#)

Operating with a setup password enabled

If **Setup Password** is set to **Enabled**, type the correct setup password before modifying the system setup options.

If you do not type the correct password in three attempts, the system displays the following message:

```
Invalid Password! Number of unsuccessful password attempts: <x> System Halted! Must power down.
```

Even after you turn off and restart the system, the error message is displayed until the correct password is typed. The following options are exceptions:

- If **System Password** is not set to **Enabled** and is not locked through the **Password Status** option, you can assign a system password. For more information, see the System Security Settings screen section.
- You cannot disable or change an existing system password.

NOTE: You can use the password status option with the setup password option to protect the system password from unauthorized changes.

Related link

[System Security](#)

Memory Settings

You can use the **Memory Settings** screen to view all the memory settings and enable or disable specific memory functions, such as system memory testing and node interleaving.

Related links

- [Memory Settings details](#)
- [System BIOS](#)
- [Viewing Memory Settings](#)

Viewing Memory Settings

To view the **Memory Settings** screen, perform the following steps:

- 1 Turn on, or restart your system.
- 2 Press F2 immediately after you see the following message:
`F2 = System Setup`
- 3 On the **System Setup Main Menu** screen, click **System BIOS**.
- 4 On the **System BIOS** screen, click **Memory Settings**.

NOTE: If your operating system begins to load before you press F2, wait for the system to finish booting, and then restart your system and try again.

Related links

- [Memory Settings](#)
- [Memory Settings details](#)

Memory Settings details

The **Memory Settings** screen details are explained as follows:

Option	Description
System Memory Size	Specifies the memory size in the system.
System Memory Type	Specifies the type of memory installed in the system.
System Memory Speed	Specifies the system memory speed.
System Memory Voltage	Specifies the system memory voltage.
Video Memory	Specifies the amount of video memory.
System Memory Testing	Specifies whether the system memory tests are run during system boot. Options are Enabled and Disabled . This option is set to Disabled by default.
Memory Operating Mode	Specifies the memory operating mode. The options available are Optimizer Mode , Advanced ECC Mode , Mirror Mode , Spare Mode , Spare with Advanced ECC Mode , Dell Fault Resilient Mode and Dell NUMA Fault Resilient Mode . This option is set to Optimizer Mode by default.

NOTE: The **Memory Operating Mode** option can have different default and available options based on the memory configuration of your system.

NOTE: The **Dell Fault Resilient Mode** option establishes an area of memory that is fault resilient. This mode can be used by an operating system that supports the feature to load critical applications or enables the operating system kernel to maximize system availability.

Option	Description
Node Interleaving	Specifies if Non-Uniform Memory architecture (NUMA) is supported. If this field is set to Enabled , memory interleaving is supported if a symmetric memory configuration is installed. If the field is set to Disabled , the system supports NUMA (asymmetric) memory configurations. This option is set to Disabled by default.
Snoop Mode	Specifies the Snoop Mode options. The Snoop Mode options available are Home Snoop , Early Snoop , and Cluster on Die . This option is set to Early Snoop by default. This field is available only when the Node Interleaving is set to Disabled .

Related links

- [Memory Settings](#)
- [Viewing Memory Settings](#)

Processor Settings

You can use the **Processor Settings** screen to view the processor settings, and perform specific functions such as enabling virtualization technology, hardware prefetcher, and logical processor idling.

Related links

- [Processor Settings details](#)
- [System BIOS](#)
- [Viewing Processor Settings](#)

Viewing Processor Settings

To view the **Processor Settings** screen, perform the following steps:

- 1 Turn on, or restart your system.
- 2 Press F2 immediately after you see the following message:

F2 = System Setup

NOTE: If your operating system begins to load before you press F2, wait for the system to finish booting, and then restart your system and try again.

- 3 On the **System Setup Main Menu** screen, click **System BIOS**.
- 4 On the **System BIOS** screen, click **Processor Settings**.

Related links

- [Processor Settings](#)
- [Processor Settings details](#)

Processor Settings details

The **Processor Settings** screen details are explained as follows:

Option	Description
Logical Processor	Enables or disables the logical processors and displays the number of logical processors. If this option is set to Enabled , the BIOS displays all the logical processors. If this option is set to Disabled , the BIOS displays only one logical processor per core. This option is set to Enabled by default.
QPI Speed	Enables you to control QuickPath Interconnect data rate settings.
Alternate RTID (Requestor Transaction ID) Setting	Modifies Requestor Transaction IDs, which are QPI resources. This option is set to Disabled by default. NOTE: Enabling this option may negatively impact the overall system performance.
Virtualization Technology	Enables or disables the additional hardware capabilities provided for virtualization. This option is set to Enabled by default.

Option	Description
Address Translation Service (ATS)	Defines the Address Translation Cache (ATC) for devices to cache the DMA transactions. This option provides an interface between CPU and DMA Memory Management to a chipset's Address Translation and Protection Table to translate DMA addresses to host addresses. This option is set to Enabled by default.
Adjacent Cache Line Prefetch	Optimizes the system for applications that need high utilization of sequential memory access. This option is set to Enabled by default. You can disable this option for applications that need high utilization of random memory access.
Hardware Prefetcher	Enables or disables the hardware prefetcher. This option is set to Enabled by default.
DCU Streamer Prefetcher	Enables or disables the Data Cache Unit (DCU) streamer prefetcher. This option is set to Enabled by default.
DCU IP Prefetcher	Enables or disables the Data Cache Unit (DCU) IP prefetcher. This option is set to Enabled by default.
Execute Disable	Enables you to run the disable memory protection technology. This option is set to Enabled by default.
Logical Processor Idling	Enables you to improve the energy efficiency of a system. It uses the operating system core parking algorithm and parks some of the logical processors in the system which in turn allows the corresponding processor cores to transition into a lower power idle state. This option can only be enabled if the operating system supports it. It is set to Disabled by default.
Configurable TDP	Enables you to reconfigure the processor Thermal Design Power (TDP) levels during POST based on the power and thermal delivery capabilities of the system. TDP verifies the maximum heat the cooling system is needed to dissipate. This option is set to Nominal by default.

 **NOTE: This option is only available on certain stock keeping units (SKUs) of the processors.**

X2Apic Mode	Enables or disables the X2Apic mode.
Dell Controlled Turbo	Controls the turbo engagement. Enable this option only when System Profile is set to Performance .  NOTE: Depending on the number of installed CPUs, there may be up to four processor listings.

Number of Cores per Processor Controls the number of enabled cores in each processor. This option is set to **All** by default.

Processor 64-bit Support Specifies if the processor(s) support 64-bit extensions.

Processor Core Speed Specifies the maximum core frequency of the processor.

Processor 1  **NOTE: Depending on the number of CPUs, there may be up to four processors listed.**

The following settings are displayed for each processor installed in the system:

Option	Description
Family-Model-Stepping	Specifies the family, model, and stepping of the processor as defined by Intel.
Brand	Specifies the brand name.
Level 2 Cache	Specifies the total L2 cache.
Level 3 Cache	Specifies the total L3 cache.
Number of Cores	Specifies the number of cores per processor.

Related links

- [Processor Settings](#)
- [Viewing Processor Settings](#)

SATA Settings

You can use the **SATA Settings** screen to view the SATA settings of SATA devices and enable RAID on your system.

Related links

- [SATA Settings details](#)
- [System BIOS](#)
- [Viewing SATA Settings](#)

Viewing SATA Settings

To view the **SATA Settings** screen, perform the following steps:

- 1 Turn on, or restart your system.
- 2 Press F2 immediately after you see the following message:
F2 = System Setup

NOTE: If your operating system begins to load before you press F2, wait for the system to finish booting, and then restart your system and try again.

- 3 On the **System Setup Main Menu** screen, click **System BIOS**.
- 4 On the **System BIOS** screen, click **SATA Settings**.

Related links

- [SATA Settings](#)
- [SATA Settings details](#)

SATA Settings details

The **SATA Settings** screen details are explained as follows:

Option	Description								
Embedded SATA	Enables the embedded SATA option to be set to Off , ATA , AHCI , or RAID modes. This option is set to AHCI by default.								
Security Freeze Lock	Sends Security Freeze Lock command to the Embedded SATA drives during POST. This option is applicable only for ATA and AHCI modes.								
Write Cache	Enables or disables the command for Embedded SATA drives during POST.								
Port A	Sets the drive type of the selected device. For Embedded SATA settings in ATA mode, set this field to Auto to enable BIOS support. Set it to OFF to turn off BIOS support. For AHCI or RAID mode, BIOS support is always enabled.								
	<table><thead><tr><th>Option</th><th>Description</th></tr></thead><tbody><tr><td>Model</td><td>Specifies the drive model of the selected device.</td></tr><tr><td>Drive Type</td><td>Specifies the type of drive attached to the SATA port.</td></tr><tr><td>Capacity</td><td>Specifies the total capacity of the hard drive. This field is undefined for removable media devices such as optical drives.</td></tr></tbody></table>	Option	Description	Model	Specifies the drive model of the selected device.	Drive Type	Specifies the type of drive attached to the SATA port.	Capacity	Specifies the total capacity of the hard drive. This field is undefined for removable media devices such as optical drives.
Option	Description								
Model	Specifies the drive model of the selected device.								
Drive Type	Specifies the type of drive attached to the SATA port.								
Capacity	Specifies the total capacity of the hard drive. This field is undefined for removable media devices such as optical drives.								
Port B	Sets the drive type of the selected device. For Embedded SATA settings in ATA mode, set this field to Auto to enable BIOS support. Set it to OFF to turn off BIOS support. For AHCI or RAID mode, BIOS support is always enabled.								

Option	Description								
	<table border="0"> <tr> <td style="padding-right: 20px;">Option</td> <td>Description</td> </tr> <tr> <td>Model</td> <td>Specifies the drive model of the selected device.</td> </tr> <tr> <td>Drive Type</td> <td>Specifies the type of drive attached to the SATA port.</td> </tr> <tr> <td>Capacity</td> <td>Specifies the total capacity of the hard drive. This field is undefined for removable media devices such as optical drives.</td> </tr> </table>	Option	Description	Model	Specifies the drive model of the selected device.	Drive Type	Specifies the type of drive attached to the SATA port.	Capacity	Specifies the total capacity of the hard drive. This field is undefined for removable media devices such as optical drives.
Option	Description								
Model	Specifies the drive model of the selected device.								
Drive Type	Specifies the type of drive attached to the SATA port.								
Capacity	Specifies the total capacity of the hard drive. This field is undefined for removable media devices such as optical drives.								

Port C Sets the drive type of the selected device. For **Embedded SATA settings** in **ATA** mode, set this field to **Auto** to enable BIOS support. Set it to **OFF** to turn off BIOS support.
For **AHCI** or **RAID** mode, BIOS support is always enabled.

Option	Description
Model	Specifies the drive model of the selected device.
Drive Type	Specifies the type of drive attached to the SATA port.
Capacity	Specifies the total capacity of the hard drive. This field is undefined for removable media devices such as optical drives.

Port D Sets the drive type of the selected device. For **Embedded SATA settings** in **ATA** mode, set this field to **Auto** to enable BIOS support. Set it to **OFF** to turn off BIOS support.
For **AHCI** or **RAID** mode, BIOS support is always enabled.

Option	Description
Model	Specifies the drive model of the selected device.
Drive Type	Specifies the type of drive attached to the SATA port.
Capacity	Specifies the total capacity of the hard drive. This field is undefined for removable media devices such as optical drives.

Port E Sets the drive type of the selected device. For **Embedded SATA settings** in **ATA** mode, set this field to **Auto** to enable BIOS support. Set it to **OFF** to turn off BIOS support.
For **AHCI** or **RAID** mode, BIOS support is always enabled.

Option	Description
Model	Specifies the drive model of the selected device.
Drive Type	Specifies the type of drive attached to the SATA port.
Capacity	Specifies the total capacity of the hard drive. This field is undefined for removable media devices such as optical drives.

Port F Sets the drive type of the selected device. For **Embedded SATA settings** in **ATA** mode, set this field to **Auto** to enable BIOS support. Set it to **OFF** to turn off BIOS support.
For **AHCI** or **RAID** mode, BIOS support is always enabled.

Option	Description
Model	Specifies the drive model of the selected device.
Drive Type	Specifies the type of drive attached to the SATA port.
Capacity	Specifies the total capacity of the hard drive. This field is undefined for removable media devices such as optical drives.

Option **Description**

Port G Sets the drive type of the selected device. For **Embedded SATA settings** in **ATA** mode, set this field to **Auto** to enable BIOS support. Set it to **OFF** to turn off BIOS support.
For **AHCI** or **RAID** mode, BIOS support is always enabled.

Option	Description
Model	Specifies the drive model of the selected device.
Drive Type	Specifies the type of drive attached to the SATA port.
Capacity	Specifies the total capacity of the hard drive. This field is undefined for removable media devices such as optical drives.

Port H Sets the drive type of the selected device. For **Embedded SATA settings** in **ATA** mode, set this field to **Auto** to enable BIOS support. Set it to **OFF** to turn off BIOS support.
For **AHCI** or **RAID** mode, BIOS support is always enabled.

Option	Description
Model	Specifies the drive model of the selected device.
Drive Type	Specifies the type of drive attached to the SATA port.
Capacity	Specifies the total capacity of the hard drive. This field is undefined for removable media devices such as optical drives.

Port I Sets the drive type of the selected device. For **Embedded SATA settings** in **ATA** mode, set this field to **Auto** to enable BIOS support. Set it to **OFF** to turn off BIOS support.
For **AHCI** or **RAID** mode, BIOS support is always enabled.

Option	Description
Model	Specifies the drive model of the selected device.
Drive Type	Specifies the type of drive attached to the SATA port.
Capacity	Specifies the total capacity of the hard drive. This field is undefined for removable media devices such as optical drives.

Port J Sets the drive type of the selected device. For **Embedded SATA settings** in **ATA** mode, set this field to **Auto** to enable BIOS support. Set it to **OFF** to turn off BIOS support.
For **AHCI** or **RAID** mode, BIOS support is always enabled.

Option	Description
Model	Specifies the drive model of the selected device.
Drive Type	Specifies the type of drive attached to the SATA port.
Capacity	Specifies the total capacity of the hard drive. This field is undefined for removable media devices such as optical drives.

Related links

[SATA Settings](#)

[Viewing SATA Settings](#)

Integrated Devices

You can use the **Integrated Devices** screen to view and configure the settings of all integrated devices including the video controller, integrated RAID controller, and the USB ports.

Related links

[Integrated Devices details](#)

[System BIOS](#)

[Viewing Integrated Devices](#)

Viewing Integrated Devices

To view the **Integrated Devices** screen, perform the following steps:

- 1 Turn on, or restart your system.
- 2 Press F2 immediately after you see the following message:

F2 = System Setup

NOTE: If your operating system begins to load before you press F2, wait for the system to finish booting, and then restart your system and try again.

- 3 On the **System Setup Main Menu** screen, click **System BIOS**.
- 4 On the **System BIOS** screen, click **Integrated Devices**.

Related links

[Integrated Devices](#)

[Integrated Devices details](#)

Integrated Devices details

The **Integrated Devices** screen details are explained as follows:

Option	Description
USB 3.0 Setting	Enables or disables the USB 3.0 support. Enable this option only if your operating system supports USB 3.0. If you disable this option, devices operate at USB 2.0 speed. USB 3.0 is enabled by default.
User Accessible USB Ports	Enables or disables the USB ports. Selecting Only Back Ports On disables the front USB ports, selecting All Ports Off disables all USB ports. The USB keyboard and mouse operate during boot process in certain operating systems. After the boot process is complete, the USB keyboard and mouse do not work if the ports are disabled. NOTE: Selecting Only Back Ports On and All Ports Off disables the USB management port and also restricts access to iDRAC features.
Internal USB Port	Enables or disables the internal USB port. This option is set to Enabled by default.
Integrated RAID Controller	Enables or disables the integrated RAID controller. This option is set to Enabled by default.
Integrated Network Card 1	Enables or disables the integrated network card.
Embedded NIC1 and NIC2	NOTE: The Embedded NIC1 and NIC2 options are only available on systems that do not have Integrated Network Card 1 . Enables or disables the Embedded NIC1 and NIC2 options. If set to Disabled , the NIC may still be available for shared network access by the embedded management controller. The embedded NIC1 and NIC2 options are only available on systems that do not have Network Daughter Cards (NDCs). The Embedded NIC1 and NIC2 option is mutually exclusive with the Integrated Network Card 1 option. Configure the Embedded NIC1 and NIC2 option by using the NIC management utilities of the system.

Option	Description
I/OAT DMA Engine	Enables or disables the I/OAT option. Enable only if the hardware and software support the feature.
Embedded Video Controller	Enables or disables the Embedded Video Controller option. This option is set to Enabled by default.
Current State of Embedded Video Controller	Displays the current state of the embedded video controller. The Current State of Embedded Video Controller option is a read-only field. If the Embedded Video Controller is the only display capability in the system (that is, no add-in graphics card is installed), then the Embedded Video Controller is automatically used as the primary display even if the Embedded Video Controller setting is set to Disabled .
SR-IOV Global Enable	Enables or disables the BIOS configuration of Single Root I/O Virtualization (SR-IOV) devices. This option is set to Disabled by default.
OS Watchdog Timer	If your system stops responding, this watchdog timer aids in the recovery of your operating system. When this option is set to Enabled , the operating system initializes the timer. When this option is set to Disabled (the default), the timer does not have any effect on the system.
Memory Mapped I/O above 4 GB	Enables or disables the support for PCIe devices that need large amounts of memory. This option is set to Enabled by default.
Slot Disablement	Enables or disables the available PCIe slots on your system. The slot disablement feature controls the configuration of PCIe cards installed in the specified slot. Slots must be disabled only when the installed peripheral card prevents booting into the operating system or causes delays in system startup. If the slot is disabled, both the Option ROM and UEFI drivers are disabled.

Related links

- [Integrated Devices](#)
- [Viewing Integrated Devices](#)

Serial Communication

You can use the **Serial Communication** screen to view the properties of the serial communication port.

Related links

- [Serial Communication details](#)
- [System BIOS](#)
- [Viewing Serial Communication](#)

Viewing Serial Communication

To view the **Serial Communication** screen, perform the following steps:

- 1 Turn on, or restart your system.
- 2 Press F2 immediately after you see the following message:

- 3 On the **System Setup Main Menu** screen, click **System BIOS**.
- 4 On the **System BIOS** screen, click **Serial Communication**.

NOTE: If your operating system begins to load before you press F2, wait for the system to finish booting, and then restart your system and try again.

Related links

- [Serial Communication](#)
- [Serial Communication details](#)

Serial Communication details

The **Serial Communication** screen details are explained as follows:

Option	Description
Serial Communication	Selects serial communication devices (Serial Device 1 and Serial Device 2) in BIOS. BIOS console redirection can also be enabled and the port address can be specified. This option is set to Auto by default.
Serial Port Address	Enables you to set the port address for serial devices. This option is set to Serial Device 1=COM2, Serial Device 2=COM1 by default. <p>NOTE: You can use only Serial Device 2 for the Serial Over LAN (SOL) feature. To use console redirection by SOL, configure the same port address for console redirection and the serial device.</p> <p>NOTE: Every time the system boots, the BIOS syncs the serial MUX setting saved in iDRAC. The serial MUX setting can independently be changed in iDRAC. Loading the BIOS default settings from within the BIOS setup utility may not always revert the serial MUX setting to the default setting of Serial Device 1.</p>
External Serial Connector	Enables you to associate the External Serial Connector to Serial Device 1, Serial Device 2, or the Remote Access Device by using this option. <p>NOTE: Only Serial Device 2 can be used for Serial Over LAN (SOL). To use console redirection by SOL, configure the same port address for console redirection and the serial device.</p> <p>NOTE: Every time the system boots, the BIOS syncs the serial MUX setting saved in iDRAC. The serial MUX setting can independently be changed in iDRAC. Loading the BIOS default settings from within the BIOS setup utility may not always revert this setting to the default setting of Serial Device 1.</p>
Failsafe Baud Rate	Specifies the failsafe baud rate for console redirection. The BIOS attempts to determine the baud rate automatically. This failsafe baud rate is used only if the attempt fails, and the value must not be changed. This option is set to 115200 by default.
Remote Terminal Type	Sets the remote console terminal type. This option is set to VT 100/VT 220 by default.
Redirection After Boot	Enables or disables the BIOS console redirection when the operating system is loaded. This option is set to Enabled by default.

Related links

- [Serial Communication](#)
- [Viewing Serial Communication](#)

System Profile Settings

You can use the **System Profile Settings** screen to enable specific system performance settings such as power management.

Related links

- [System Profile Settings details](#)
- [System BIOS](#)
- [Viewing System Profile Settings](#)

Viewing System Profile Settings

To view the **System Profile Settings** screen, perform the following steps:

- 1 Turn on, or restart your system.
- 2 Press F2 immediately after you see the following message:

F2 = System Setup

NOTE: If your operating system begins to load before you press F2, wait for the system to finish booting, and then restart your system and try again.

- 3 On the **System Setup Main Menu** screen, click **System BIOS**.
- 4 On the **System BIOS** screen, click **System Profile Settings**.

Related links



[System Profile Settings](#)

[System Profile Settings details](#)

System Profile Settings details

The **System Profile Settings** screen details are explained as follows:

Option	Description
System Profile	<p>Sets the system profile. If you set the System Profile option to a mode other than Custom, the BIOS automatically sets the rest of the options. You can only change the rest of the options if the mode is set to Custom. This option is set to Performance Per Watt Optimized (DAPC) by default. DAPC is Dell Active Power Controller.</p> <p> NOTE: All the parameters on the system profile setting screen are available only when the System Profile option is set to Custom.</p>
CPU Power Management	<p>Sets the CPU power management. This option is set to System DBPM (DAPC) by default. DBPM is Demand-Based Power Management.</p>
Memory Frequency	<p>Sets the speed of the system memory. You can select Maximum Performance, Maximum Reliability, or a specific speed.</p>
Turbo Boost	<p>Enables or disables the processor to operate in the turbo boost mode. This option is set to Enabled by default.</p>
Energy Efficient Turbo	<p>Enables or disables the Energy Efficient Turbo option.</p> <p>Energy Efficient Turbo (EET) is a mode of operation where a processor's core frequency is adjusted to be within the turbo range based on workload.</p>
C1E	<p>Enables or disables the processor to switch to a minimum performance state when it is idle. This option is set to Enabled by default.</p>
C States	<p>Enables or disables the processor to operate in all available power states. This option is set to Enabled by default.</p>
Collaborative CPU Performance Control	<p>Enables or disables the CPU power management option. When set to Enabled, the CPU power management is controlled by the OS DBPM and the System DBPM (DAPC). This option is set to Disabled by default.</p>
Memory Patrol Scrub	<p>Sets the memory patrol scrub frequency. This option is set to Standard by default.</p>
Memory Refresh Rate	<p>Sets the memory refresh rate to either 1x or 2x. This option is set to 1x by default.</p>
Uncore Frequency	<p>Enables you to select the Processor Uncore Frequency option.</p> <p>Dynamic mode enables the processor to optimize power resources across the cores and uncore during runtime. The optimization of the uncore frequency to either save power or optimize performance is influenced by the setting of the Energy Efficiency Policy option.</p>
Energy Efficient Policy	<p>Enables you to select the Energy Efficient Policy option.</p> <p>The CPU uses the setting to manipulate the internal behavior of the processor and determines whether to target higher performance or better power savings.</p>
Number of Turbo Boot Enabled Cores for Processor 1	<p> NOTE: If there are two processors installed in the system, you see an entry for Number of Turbo Boost Enabled Cores for Processor 2.</p> <p>Controls the number of turbo boost enabled cores for processor 1. The maximum number of cores is enabled by default.</p>
Monitor/Mwait	<p>Enables the Monitor/Mwait instructions in the processor. This option is set to Enabled for all system profiles, except Custom by default.</p>

Option	Description
	<p> NOTE: This option can be disabled only if the C States option in the Custom mode is set to disabled.</p> <p> NOTE: When C States is set to Enabled in the Custom mode, changing the Monitor/Mwait setting does not impact the system power or performance.</p>

Related links

- [System Profile Settings](#)
- [Viewing System Profile Settings](#)

Miscellaneous Settings

You can use the **Miscellaneous Settings** screen to perform specific functions such as updating the asset tag and changing the system date and time.

Related links

- [Miscellaneous Settings details](#)
- [System BIOS](#)
- [Viewing Miscellaneous Settings](#)

Viewing Miscellaneous Settings

To view the **Miscellaneous Settings** screen, perform the following steps:

- 1 Turn on, or restart your system.
- 2 Press F2 immediately after you see the following message:

```
F2 = System Setup
```

 **NOTE:** If your operating system begins to load before you press F2, wait for the system to finish booting, and then restart your system and try again.
- 3 On the **System Setup Main Menu** screen, click **System BIOS**.
- 4 On the **System BIOS** screen, click **Miscellaneous Settings**.

Related links

- [Miscellaneous Settings](#)
- [Miscellaneous Settings details](#)

Miscellaneous Settings details

The **Miscellaneous Settings** screen details are explained as follows:

Option	Description
System Time	Enables you to set the time on the system.
System Date	Enables you to set the date on the system.
Asset Tag	Specifies the asset tag and enables you to modify it for security and tracking purposes.
Keyboard NumLock	Enables you to set whether the system boots with the NumLock enabled or disabled. This option is set to On by default.  NOTE: This option does not apply to 84-key keyboards.
F1/F2 Prompt on Error	Enables or disables the F1/F2 prompt on error. This option is set to Enabled by default. The F1/F2 prompt also includes keyboard errors.

Option	Description
Load Legacy Video Option ROM	Enables you to determine whether the system BIOS loads the legacy video (INT 10H) option ROM from the video controller. Selecting Enabled in the operating system does not support UEFI video output standards. This field is available only for UEFI boot mode. You cannot set the option to Enabled if UEFI Secure Boot mode is enabled.
In-System Characterization	<p>Enables or disables In-System Characterization. This option is set to Disabled by default. The two other options are Enabled and Enabled - No Reboot.</p> <p>i NOTE: The default setting for In-System Characterization is subject to change in future BIOS releases.</p> <p>When enabled, In-System Characterization (ISC) executes during POST upon detecting relevant change(s) in system configuration to optimize system power and performance. ISC takes about 20 seconds to execute, and system reset is needed for ISC results to be applied. The Enabled - No Reboot option executes ISC and continues without applying ISC results until the next time system reset occurs. The Enabled option executes ISC and forces an immediate system reset so that ISC results can be applied. It takes the system longer to be ready due to the forced system reset. When disabled, ISC does not execute.</p>

Related links

- [Miscellaneous Settings](#)
- [Viewing Miscellaneous Settings](#)

iDRAC Settings utility

The iDRAC settings utility is an interface to set up and configure the iDRAC parameters by using UEFI. You can enable or disable various iDRAC parameters by using the iDRAC settings utility.

i **NOTE:** Accessing some of the features on the iDRAC settings utility needs the iDRAC Enterprise License upgrade.

For more information about using iDRAC, see *Dell Integrated Dell Remote Access Controller User's Guide* at Dell.com/idracmanuals.

Related links

- [Device Settings](#)
- [System BIOS](#)
- [Entering the iDRAC Settings utility](#)
- [Changing the thermal settings](#)

Entering the iDRAC Settings utility

- 1 Turn on or restart the managed system.
- 2 Press F2 during Power-on Self-test (POST).
- 3 On the **System Setup Main Menu** page, click **iDRAC Settings**.
The **iDRAC Settings** screen is displayed.

Related link

- [iDRAC Settings utility](#)

Changing the thermal settings

The iDRAC settings utility enables you to select and customize the thermal control settings for your system.

- 1 Click **iDRAC Settings > Thermal**.
- 2 Under **SYSTEM THERMAL PROFILE > Thermal Profile**, select one of the following options:
 - Default Thermal Profile Settings

- Maximum Performance (Performance Optimized)
 - Minimum Power (Performance per Watt Optimized)
- 3 Under **USER COOLING OPTIONS**, set the **Fan Speed Offset**, **Minimum Fan Speed**, and **Custom Minimum Fan Speed**.
 - 4 Click **Back > Finish > Yes**.

Related link

[iDRAC Settings utility](#)

Device Settings

Device Settings enables you to configure device parameters.

Related link

[System BIOS](#)

Dell Lifecycle Controller

Dell Lifecycle Controller (LC) provides advanced embedded systems management capabilities including system deployment, configuration, update, maintenance, and diagnosis. LC is delivered as part of the iDRAC out-of-band solution and Dell system embedded Unified Extensible Firmware Interface (UEFI) applications.

Related link

[Embedded system management](#)

Embedded system management

The Dell Lifecycle Controller provides advanced embedded systems management throughout the system's lifecycle. The Dell Lifecycle Controller can be started during the boot sequence and can function independently of the operating system.

NOTE: Certain platform configurations may not support the full set of features provided by the Dell Lifecycle Controller.

For more information about setting up the Dell Lifecycle Controller, configuring hardware and firmware, and deploying the operating system, see the Dell Lifecycle Controller documentation at Dell.com/idracmanuals.

Related link

[Dell Lifecycle Controller](#)

Boot Manager

The **Boot Manager** screen enables you to select boot options and diagnostic utilities.

Related links

[Boot Manager main menu](#)

[System BIOS](#)

[Viewing Boot Manager](#)

Viewing Boot Manager

To enter **Boot Manager**:

- 1 Turn on, or restart your system.
- 2 Press F11 when you see the following message:

```
F11 = Boot Manager
```

If your operating system begins to load before you press F11, allow the system to complete the booting, and then restart your system and try again.

Related links

[Boot Manager](#)

[Boot Manager main menu](#)

Boot Manager main menu

Menu item	Description
Continue Normal Boot	The system attempts to boot to devices starting with the first item in the boot order. If the boot attempt fails, the system continues with the next item in the boot order until the boot is successful or no more boot options are found.
One-shot Boot Menu	Enables you to access boot menu, where you can select a one-time boot device to boot from.
Launch System Setup	Enables you to access System Setup.
Launch Lifecycle Controller	Exits the Boot Manager and invokes the Dell Lifecycle Controller program.
System Utilities	Enables you to launch System Utilities menu such as System Diagnostics and UEFI shell.

Related links

[Boot Manager](#)

[Viewing Boot Manager](#)

One-shot BIOS boot menu

One-shot BIOS boot menu enables you to select a one-shot boot device to boot from the following options:

- Launch Diagnostics
- BIOS Update File Explorer
- Reboot System

Related link

[Boot Manager](#)

System Utilities

System Utilities contains the following utilities that can be launched:

- Launch Diagnostics
- BIOS Update File Explorer
- Reboot System

Related link

[Boot Manager](#)

PXE boot

The Preboot Execution Environment (PXE) is an industry standard client or interface that allows networked computers that are not yet loaded with an operating system to be configured and booted remotely by an administrator.

Installing and removing system components

This section provides information about installing and removing the system components.

Topics:

- Safety instructions
- Before working inside your system
- After working inside your system
- Recommended tools
- Front bezel (optional)
- System feet
- Caster wheels (optional)—tower mode
- System cover
- Inside the system
- Cooling shroud
- Cooling fans
- Cooling-fan assembly (optional)
- System memory
- Flex bays
- Hard drives
- Optical drives and tape drives
- Internal USB memory key (optional)
- Expansion card holder
- Expansion cards
- GPU card holder (optional)
- GPU cards (optional)
- Internal dual SD module (optional)
- Internal SD card
- Processors and heat sinks
- Power supply unit
- System battery
- Hard drive backplane
- SD vFlash media card (optional)
- Control panel assembly
- System board
- Trusted Platform Module
- Power interposer board and power distribution board

Safety instructions

CAUTION: Many repairs may only be done by a certified service technician. You should only perform troubleshooting and simple repairs as authorized in your product documentation, or as directed by the online or telephone service and support team. Damage due to servicing that is not authorized by Dell is not covered by your warranty. Read and follow the safety instructions that came with the product.

CAUTION: Do not attempt to convert your system into a rack unless authorized by Dell. Only customers certified by Dell for tower to rack conversion can convert a tower system into a rack system.

NOTE: For specific caution statements and procedures, see the rack installation documentation for your system at Dell.com/poweredgemanuals. For complete safety and regulatory information, see the safety instructions that shipped with your system.

Observe the following precautions for stability and safety of the system in rack mode:

- Before installing your equipment in a rack, install the front and side rack stabilizers. Failure to install the stabilizers can cause the rack to tip over.
- Always load from bottom up, and load the heaviest items first.
- Do not overload the AC power supply branch circuit that provides power to the rack.

Before working inside your system

Prerequisite

Follow the safety guidelines listed in the Safety instructions section.

Steps

- 1 Turn off the system, including any attached peripherals.
- 2 Disconnect the system from the electrical outlet and disconnect the peripherals.
- 3 If installed, remove the front bezel.
- 4 If applicable, remove the system from the rack.
For more information, see the *Rack Installation* placemat at Dell.com/poweredgemanuals.
- 5 Lay the system on its side.
- 6 Remove the system cover.

Related links

- [Safety instructions](#)
- [Removing the system cover](#)
- [Removing the optional front bezel](#)

After working inside your system

Prerequisite

Follow the safety guidelines listed in the Safety instructions section.

Steps

- 1 Install the system cover.
- 2 Place the system upright on its feet on a flat, stable surface.
- 3 If applicable, install the system into the rack.
For more information, see the *Rack Installation* placemat at Dell.com/poweredgemanuals.
- 4 If removed, install the optional front bezel.
- 5 Reconnect the peripherals and connect the system to the electrical outlet.
- 6 Turn on the system, including any attached peripherals.

Related links

- [Installing the system cover](#)
- [Installing the optional front bezel](#)

Recommended tools

You need the following tools to perform the removal and installation procedures:

- Key to the bezel lock. This is needed only if your system includes a bezel.
- Phillips #2 screwdriver
- Wrist grounding strap

You need the following tools to assemble the cables for a DC power supply unit.

- AMP 90871-1 hand-crimping tool or equivalent
- Tyco Electronics 58433-3 or equivalent
- Wire-stripper pliers to remove insulation from size 10 AWG solid or stranded, insulated copper wire

ⓘ | NOTE: Use alpha wire part number 3080 or equivalent (65/30 stranding).

Front bezel (optional)

The front bezel is attached to the front side of the server and prevents accidents while removing the hard drive or when pressing the reset or power button. The front bezel can also be locked for additional security.

Removing the optional front bezel

- 1 Unlock the bezel by using the bezel keys.

ⓘ | NOTE: There are two bezel keys attached to the back of the bezel.

- 2 Press the release latch at the top of the bezel.
- 3 Pull the top end of the bezel away from the system.
- 4 Remove the bezel by unhooking the bezel tabs from the slots at the bottom of the system.
- 5 Unhook the bezel tabs from the slots at the bottom of the system board, and pull the bezel away from the system.

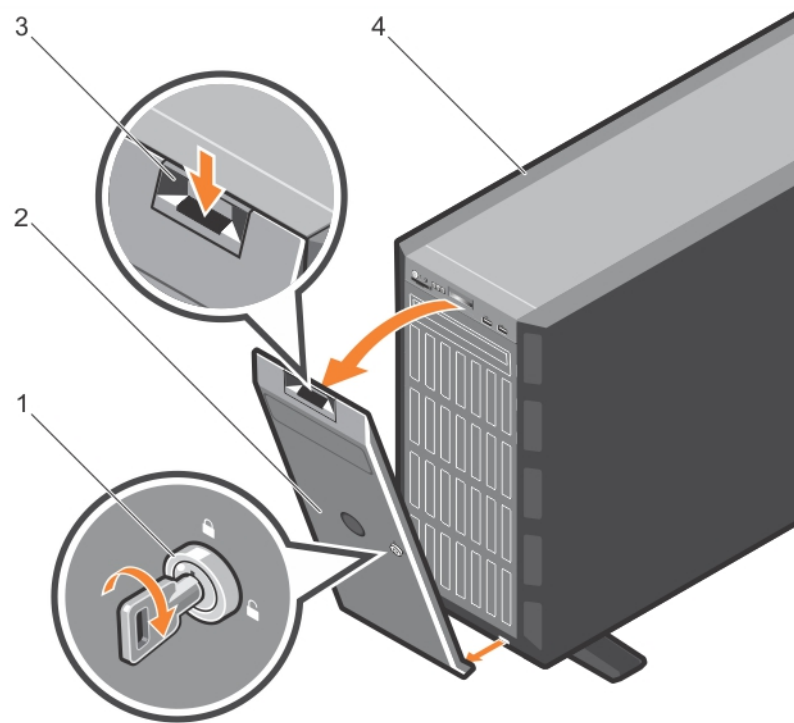

Figure 15. Removing the front bezel

- | | | | |
|---|---------------|---|--------|
| 1 | bezel key | 2 | bezel |
| 3 | release latch | 4 | system |

Related link

[Installing the optional front bezel](#)

Installing the optional front bezel

- 1 Locate and remove the bezel keys.
NOTE: There are two bezel keys attached to the back of the bezel.
- 2 Insert the bezel tabs into the bezel tab slots in the chassis.
- 3 Press the release latch, and push the bezel toward the system until the bezel locks into place.
- 4 Lock the bezel by using the key.

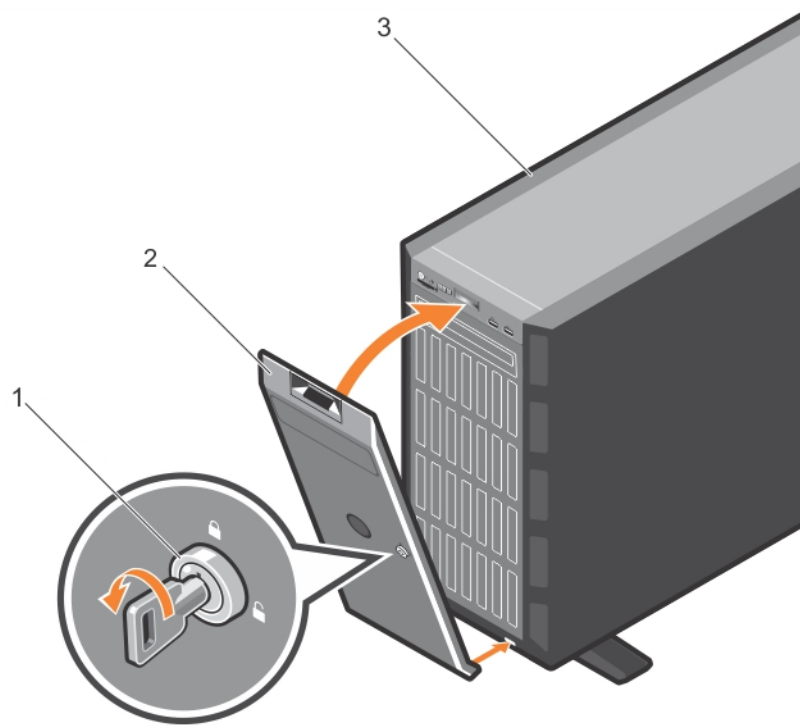

Figure 16. Installing the front bezel

- 1 bezel key
- 3 system

- 2 bezel

Related link

[Removing the optional front bezel](#)

System feet

The system feet provide stability to the system in the tower mode.

Removing the system feet

Prerequisites

NOTE: It is recommended that you remove the system feet only when you are converting the system from the tower mode to the rack mode, or when you are replacing the system feet with the wheel assembly.

- 1 Follow the safety guidelines listed in the safety instructions section.
- 2 Keep the Phillips #2 screwdriver ready.
- 3 Rotate the system feet inward.
- 4 Place the system on its side on a flat, stable surface.

Step

Remove the screws that secure the system feet to the base of the tower.

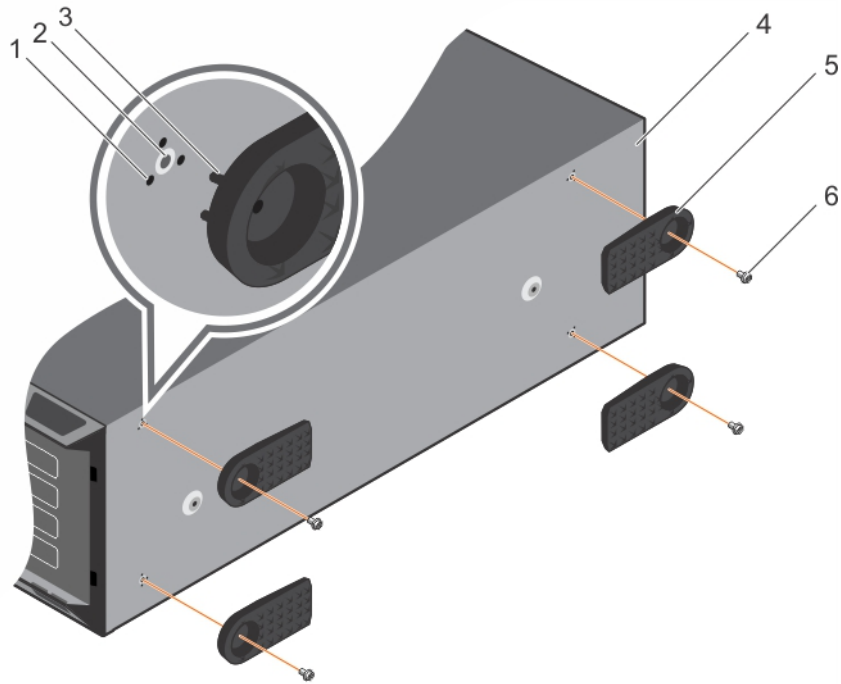

Figure 17. Removing and installing the system feet

- | | | | |
|---|-----------------|---|-------------------|
| 1 | tab slot (12) | 2 | screw hole (4) |
| 3 | tab (12) | 4 | base of the tower |
| 5 | system feet (4) | 6 | screw (4) |

Related links

- [Safety instructions](#)
- [Installing the system feet](#)

Installing the system feet

Prerequisites

⚠ CAUTION: Installing the feet on a stand-alone tower system is necessary to provide a stable foundation for the system. Failure to install the feet poses the risk of having the system tip over, possibly causing bodily injury or damage to the system.

- 1 Follow the safety guidelines listed in the safety instructions section.
- 2 Keep the Phillips #2 screwdriver ready.
- 3 Place the system on its side on a flat, stable surface.

Steps

- 1 Align the three tabs on the system feet with the three slots on the base of the chassis.
- 2 Secure the system feet to the base of the chassis by using the screws.

Next step

Place the system upright on a flat, stable surface, and turn the system feet outward.

Related links

- [Safety instructions](#)
- [Removing the system feet](#)

Caster wheels (optional)—tower mode

Caster wheels provide mobility to the system in the tower mode.

The caster wheel assembly consists of:

- Caster wheel units (front and back)
- Two screws for the caster wheel units

Removing caster wheels

Prerequisites

- 1 Follow the safety guidelines listed in the safety instructions section.
- 2 Keep the Phillips #2 screwdriver ready.
- 3 Place the system on a flat, stable surface with the wheels extending beyond the edge of the surface.

Steps

- 1 Remove the screw that secures the front wheel unit to the base of the chassis.
- 2 Offset the front wheel unit slightly to the back of the system to release the retention hooks, and pull out the front wheel unit.
- 3 Remove the screw that secures the back wheel unit to the base of the chassis.
- 4 Offset the back wheel unit slightly to the front of the system to release the retention hooks, and pull out the back wheel unit.

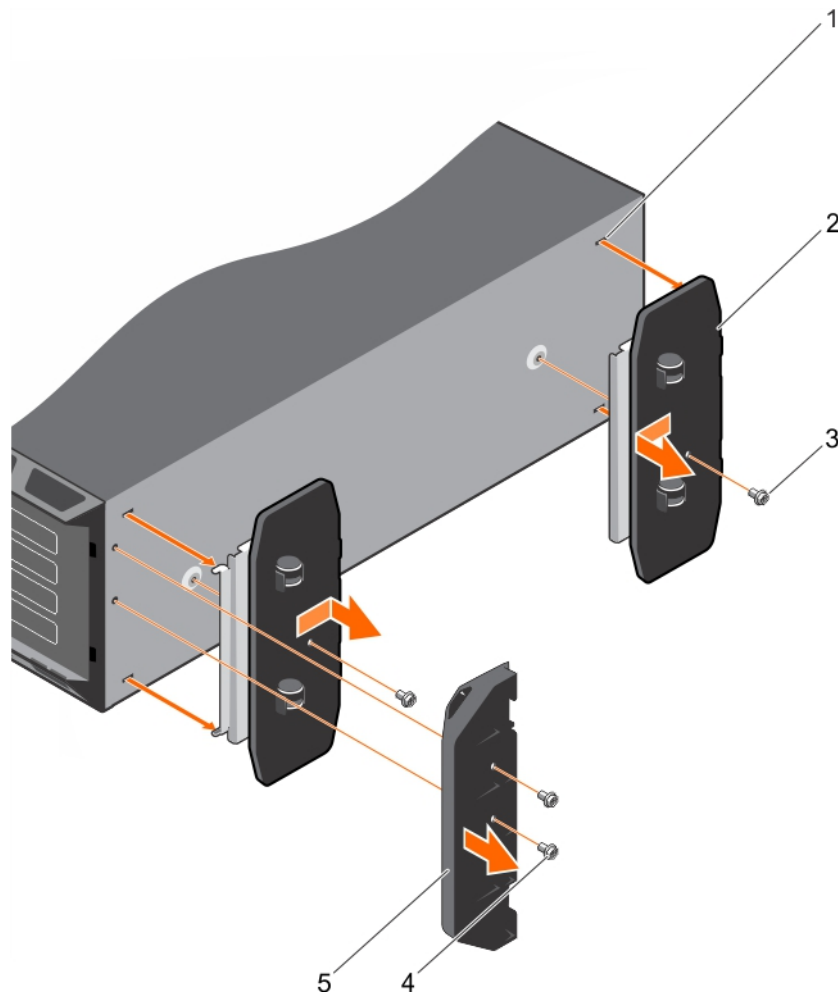

Figure 18. Removing caster wheels

- | | | | |
|---|--------------------------------|---|----------------------------|
| 1 | slots on base of the tower (4) | 2 | wheel assembly unit (2) |
| 3 | screw (2) | 4 | screw for support unit (2) |
| 5 | support unit | | |

Related links

- [Safety instructions](#)
- [Installing caster wheels](#)

Installing caster wheels

Prerequisites

- 1 Follow the safety guidelines listed in the safety instructions section.
- 2 Keep the Phillips #2 screwdriver ready.
- 3 Place the system on its side on a flat, stable surface with the base of the system extending off the edge of the surface.
- 4 If installed, remove the system feet. For more information, see the Removing system feet section.

Steps

- 1 Align the two retention hooks on the back wheel unit with the two slots on the base of the chassis, and insert the hooks into the slots.
- 2 Offset the back wheel slightly to the back of the system and secure the unit in place by using a single screw.
- 3 Align the two retention hooks on the front wheel with the two slots on the base of the chassis, and insert the hooks into the slots.
- 4 Offset the front wheel slightly to the front and secure the unit in place by using a screw.

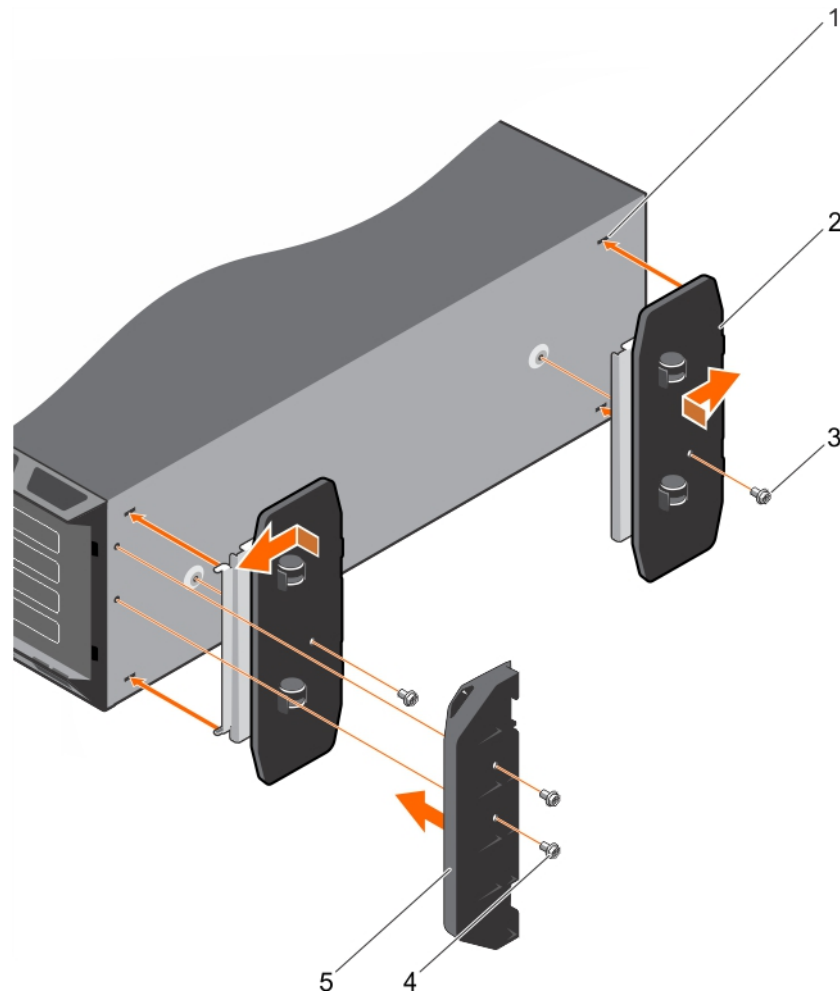

Figure 19. Installing caster wheels

- | | | | |
|---|--------------------------------|---|----------------------------|
| 1 | slots on base of the tower (4) | 2 | wheel assembly unit (2) |
| 3 | screw (2) | 4 | screw for support unit (2) |
| 5 | support unit | | |

Related links

- [Safety instructions](#)
- [Removing the system feet](#)
- [Removing caster wheels](#)

System cover

The system cover protects the components inside the system and helps in maintaining air flow inside the system. Removing the system cover actuates the intrusion switch which aids in maintaining system security.

Removing the system cover

Prerequisites

- 1 Follow the safety guidelines listed in the safety instructions section.
- 2 Turn off the system and any attached peripherals.
- 3 Disconnect the system from the electrical outlet and peripherals.
- 4 If installed, remove the front bezel.
- 5 Place the system on a flat, stable surface.

Steps

- 1 Turn the latch release lock to the unlocked position.
- 2 Press the cover release latch and remove the system cover.

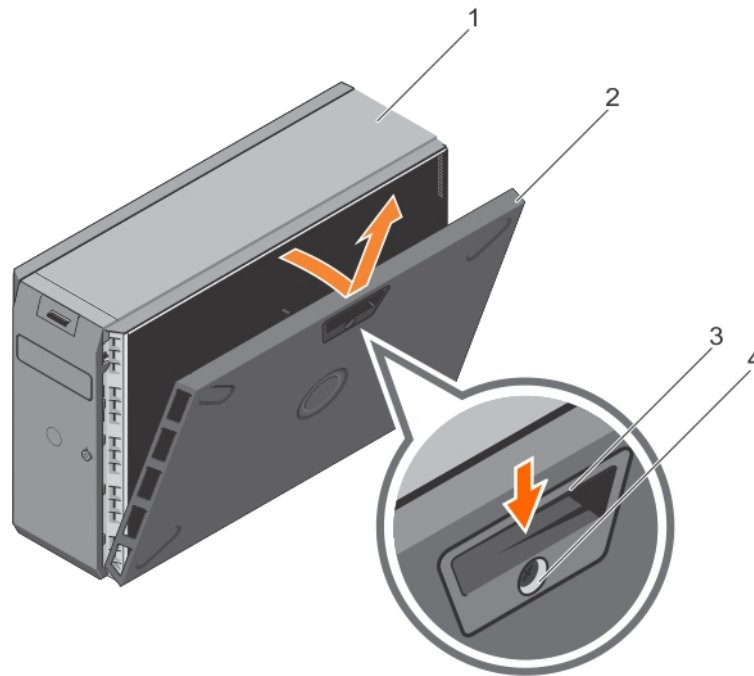

Figure 20. Removing the system cover

- | | | | |
|---|---------------------|---|--------------------------|
| 1 | system | 2 | system cover |
| 3 | cover release latch | 4 | cover release latch lock |

Next steps

- 1 Install the system cover.
- 2 Place the system upright on its feet on a flat and stable surface.
- 3 Reconnect the peripherals and connect the system to the electrical outlet.
- 4 Turn the system on, including any attached peripherals.

Related links

- [Safety instructions](#)
- [Installing the system cover](#)

Installing the system cover

Prerequisites

- 1 Follow the safety guidelines listed in the Safety instructions section.
- 2 Ensure that all internal cables are connected and placed out of the way and no tools or extra parts are left inside the system.

Steps

- 1 Align the slots on the system cover with the tabs on the chassis.
- 2 Press the cover release latch, and push the cover toward the chassis until the latch locks into place.
- 3 Rotate the latch release lock clockwise to the locked position.

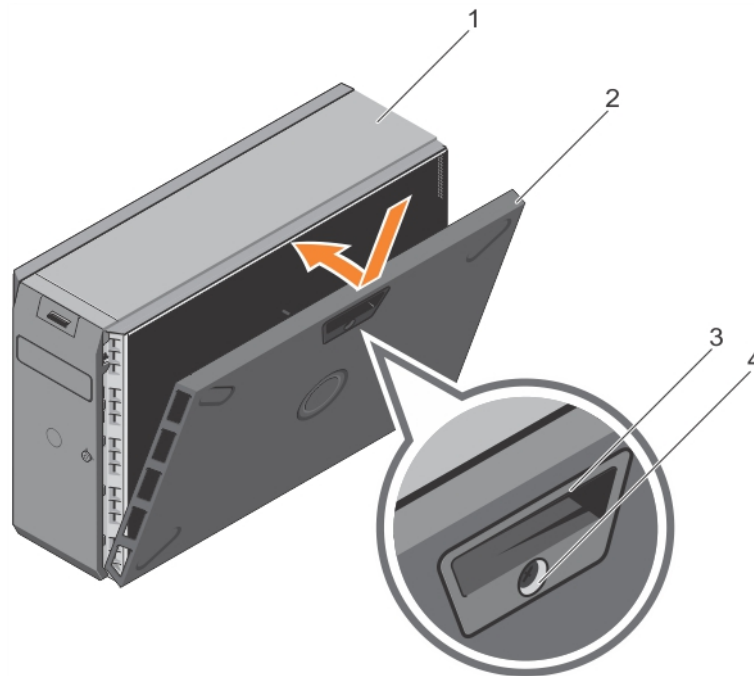

Figure 21. Installing the system cover

- | | | | |
|---|---------------------|---|--------------------------|
| 1 | system | 2 | system cover |
| 3 | cover release latch | 4 | cover release latch lock |

Next steps

- 1 Place the system upright on its feet on a flat and stable surface.
- 2 If removed, install the bezel.
- 3 Reconnect the peripherals and connect the system to the electrical outlet.
- 4 Turn on the system, including any attached peripherals.

Related links

- [Safety instructions](#)
- [Removing the system cover](#)

Inside the system

CAUTION: Many repairs may only be done by a certified service technician. You should only perform troubleshooting and simple repairs as authorized in your product documentation, or as directed by the online or telephone service and support team. Damage due to servicing that is not authorized by Dell is not covered by your warranty. Read and follow the safety instructions that are shipped with your product.

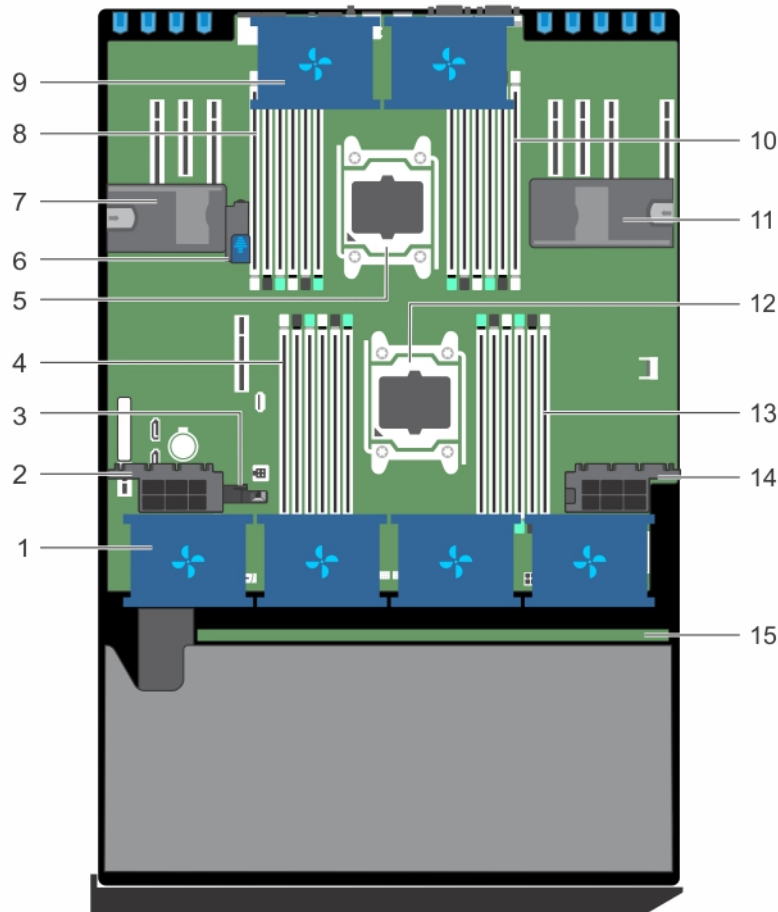

Figure 22. Inside the system

- | | | | |
|----|--|----|-----------------------|
| 1 | cooling fan in the cooling fan assembly (optional) | 2 | expansion card holder |
| 3 | guide to align the cooling shroud | 4 | DIMM slots (6) |
| 5 | processor 2 | 6 | system-board holder |
| 7 | expansion card holder | 8 | DIMM slots (6) |
| 9 | cooling fan in the cooling shroud (2) | 10 | DIMM slots (6) |
| 11 | expansion card holder | 12 | processor 1 |
| 13 | DIMM slots (6) | 14 | expansion card holder |
| 15 | hard-drive backplane | | |

Cooling shroud

The cooling shroud has aerodynamically placed openings that direct the airflow across the entire system. The airflow passes through all the critical parts of the system, where the vacuum pulls air across the entire surface area of the heat sink, thus allowing increased cooling.

Removing the cooling shroud

Prerequisites

CAUTION: Many repairs may only be done by a certified service technician. You should only perform troubleshooting and simple repairs as authorized in your product documentation, or as directed by the online or telephone service and support team. Damage due to servicing that is not authorized by Dell is not covered by your warranty. Read and follow the safety instructions that are shipped with your product.

CAUTION: Never operate your system with the cooling shroud removed. The system may get overheated quickly, resulting in shutdown of the system and loss of data.

- 1 Follow the safety guidelines listed in the Safety instructions section.
- 2 Follow the procedure listed in the Before working inside your system section.
- 3 If required, remove the two cooling fans. For more information, see the Removing a cooling fan section.

Step

Pull the cooling shroud release tab, and holding the touch points at the center of the cooling shroud, lift the shroud from the system.

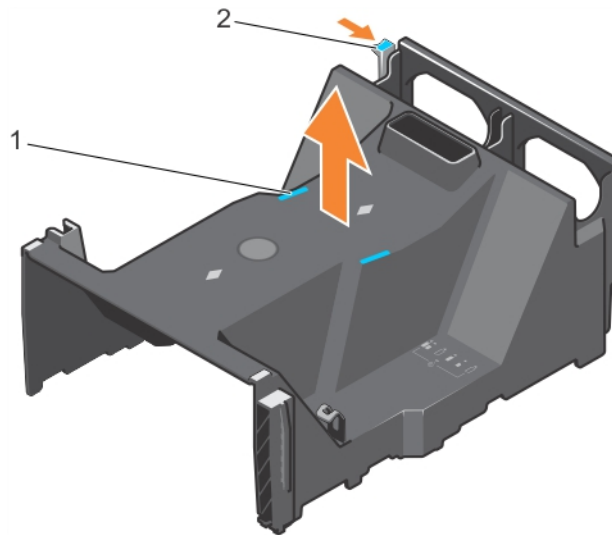

Figure 23. Removing the cooling shroud

1 touch point (2)

2 cooling shroud release tab

Next steps

- 1 Install the cooling shroud.
- 2 Follow the procedure listed in the After working inside your system section.

Related links

- [Safety instructions](#)
- [Installing the cooling shroud](#)
- [Before working inside your system](#)
- [Removing the optional cooling fan assembly](#)

Installing the cooling shroud

Prerequisites

CAUTION: Many repairs may only be done by a certified service technician. You should only perform troubleshooting and simple repairs as authorized in your product documentation, or as directed by the online or telephone service and support team. Damage due to servicing that is not authorized by Dell is not covered by your warranty. Read and follow the safety instructions that are shipped with your product.

- 1 Follow the safety guidelines listed in the Safety instructions section.
- 2 Follow the procedure listed in the Before working inside your system section.
- 3 If applicable, route the cables inside the system along the chassis wall and secure the cables by using the cable-securing bracket.

Steps

- 1 Align the tabs on the cooling shroud with the securing slots on the chassis.
- 2 Lower the cooling shroud into the chassis until it is firmly seated.
- 3 If removed, install the cooling fans in the cooling shroud.

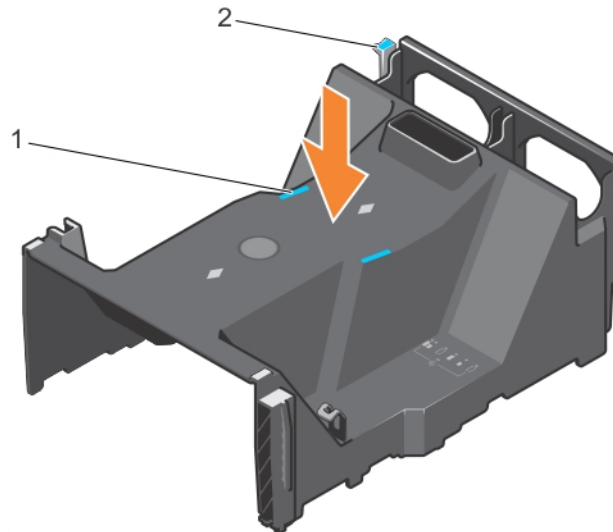

Figure 24. Installing the cooling shroud

1 touch point (2)

2 cooling shroud release tab

Next step

- 1 Follow the procedure listed in the After working inside your system section.

Related links

- [Safety instructions](#)
- [Removing the cooling shroud](#)
- [Before working inside your system](#)

Cooling fans

There are two cooling fans on the cooling shroud and an optional cooling fan assembly that houses four cooling fans on your system.

① **NOTE:** Each fan is listed in the system's management software, referenced by the respective fan number. If there is a problem with a particular fan, you can easily identify and replace the proper fan by noting the fan numbers on the cooling fan assembly.

Removing a cooling fan

Prerequisites

- 1 Follow the safety guidelines listed in the safety instructions section.
- 2 Follow the procedure listed in the Before working inside your system section.

⚠ **WARNING:** Opening or removing the system cover when the system is on may expose you to a risk of electric shock. Exercise utmost care while removing or installing cooling fans.

⚠ **CAUTION:** Many repairs may only be done by a certified service technician. You should only perform troubleshooting and simple repairs as authorized in your product documentation, or as directed by the online or telephone service and support team. Damage due to servicing that is not authorized by Dell is not covered by your warranty. Read and follow the safety instructions that are shipped with your product.

⚠ **CAUTION:** The cooling fans are hot-swappable. To maintain proper cooling while the system is on, replace only one fan at a time.

⚠ **CAUTION:** Do not operate the system with the cover removed for a duration exceeding five minutes.

① **NOTE:** The procedure for removing an individual fan from the cooling-fan assembly and the cooling shroud is identical.

Step

Press the fan release tab and lift the cooling fan out of the cooling-fan assembly.

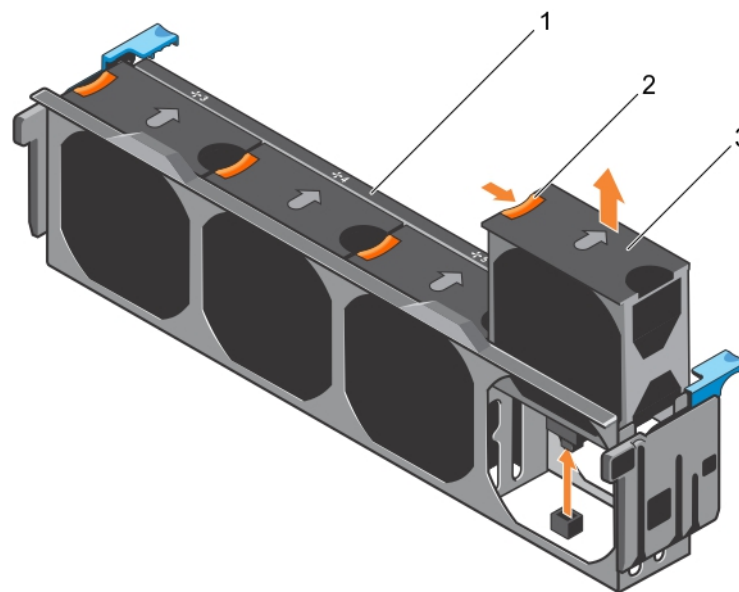

Figure 25. Removing a cooling fan from the cooling-fan assembly

- | | | | |
|---|----------------------|---|-----------------|
| 1 | cooling-fan assembly | 2 | fan release tab |
| 3 | cooling fan | | |

Related links

[Safety instructions](#)
[Before working inside your system](#)
[Installing a cooling fan](#)
[After working inside your system](#)

Installing a cooling fan

Prerequisites

CAUTION: Many repairs may only be done by a certified service technician. You should only perform troubleshooting and simple repairs as authorized in your product documentation, or as directed by the online or telephone service and support team. Damage due to servicing that is not authorized by Dell is not covered by your warranty. Read and follow the safety instructions that are shipped with your product.

NOTE: The procedure for installing an individual fan in the cooling-fan assembly and the cooling shroud is identical.

Follow the safety guidelines listed in the safety instructions section.

Steps

- 1 Align the cooling fan connector with the connector on the system board.
- 2 Slide the cooling fan into the securing slot until the tab locks into place.

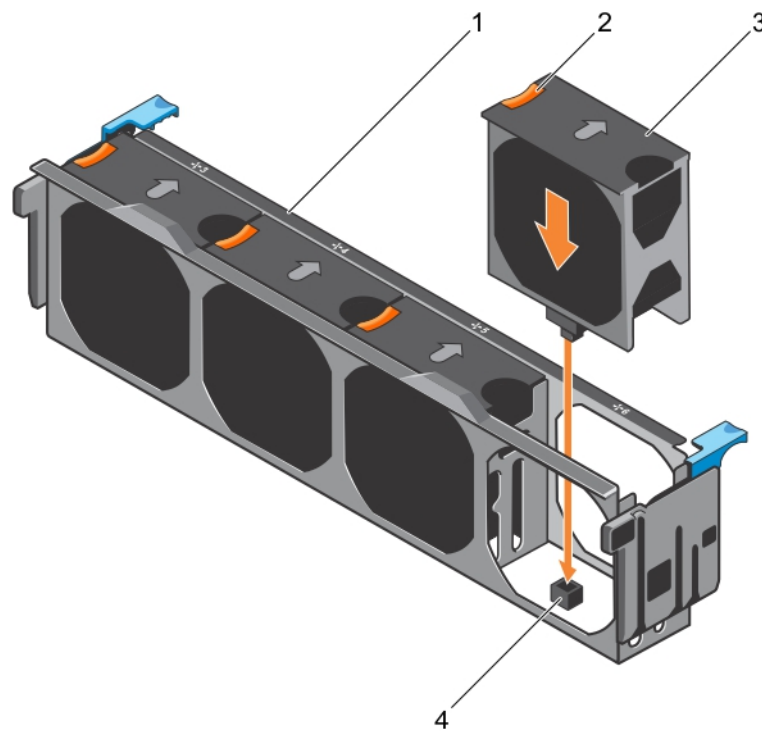

Figure 26. Installing a cooling fan into the cooling-fan assembly

Next steps

- 1 cooling-fan assembly
- 2 fan release tab
- 3 cooling fan
- 4 cooling fan connector on the system board

Related links

- [Safety instructions](#)
- [After working inside your system](#)

Cooling-fan assembly (optional)

The cooling fan assembly is an essential part of a server's cooling system. It ensures that the key components of the server such as the processors, hard drives, and memory get adequate air circulation to keep them cool. A failure in the server's cooling system can result in the server overheating and may lead to damage.

Removing the optional cooling fan assembly

Prerequisites

CAUTION: Many repairs may only be done by a certified service technician. You should only perform troubleshooting and simple repairs as authorized in your product documentation, or as directed by the online or telephone service and support team. Damage due to servicing that is not authorized by Dell is not covered by your warranty. Read and follow the safety instructions that are shipped with your product.

- 1 Follow the safety guidelines listed in the Safety instructions section.
- 2 Follow the procedure listed in the Before working inside your system section.

Steps

- 1 Unlock the cooling fan assembly from the chassis by lifting the release levers up.
- 2 Lift the cooling fan assembly out of the chassis.

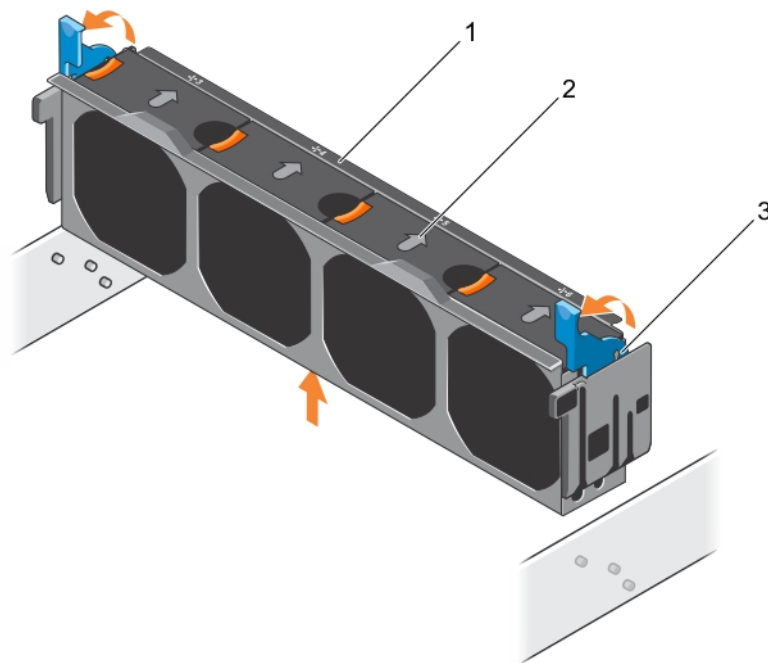

Figure 27. Removing the cooling fan assembly

- | | | | |
|---|----------------------|---|-----------------|
| 1 | cooling fan assembly | 2 | cooling fan (4) |
| 3 | release lever (2) | | |

Related links

- [Safety instructions](#)
- [Before working inside your system](#)
- [Installing the optional cooling fan assembly](#)

Installing the optional cooling fan assembly

Prerequisites

CAUTION: Many repairs may only be done by a certified service technician. You should only perform troubleshooting and simple repairs as authorized in your product documentation, or as directed by the online or telephone service and support team. Damage due to servicing that is not authorized by Dell is not covered by your warranty. Read and follow the safety instructions that are shipped with your product.

CAUTION: Ensure that the cables are correctly installed and retained by cable retention bracket before installing the cooling-fan assembly. Incorrectly installed cables may get damaged.

Follow the safety guidelines listed in the safety instructions section.

Steps

- 1 Align the slots on the cooling fan assembly with the guide pins on the chassis side walls.
- 2 Slide the cooling fan assembly into the chassis.
- 3 Lock the cooling fan assembly into the chassis by pressing the release levers down.

Next step

Follow the procedure listed in the After working inside your system section.

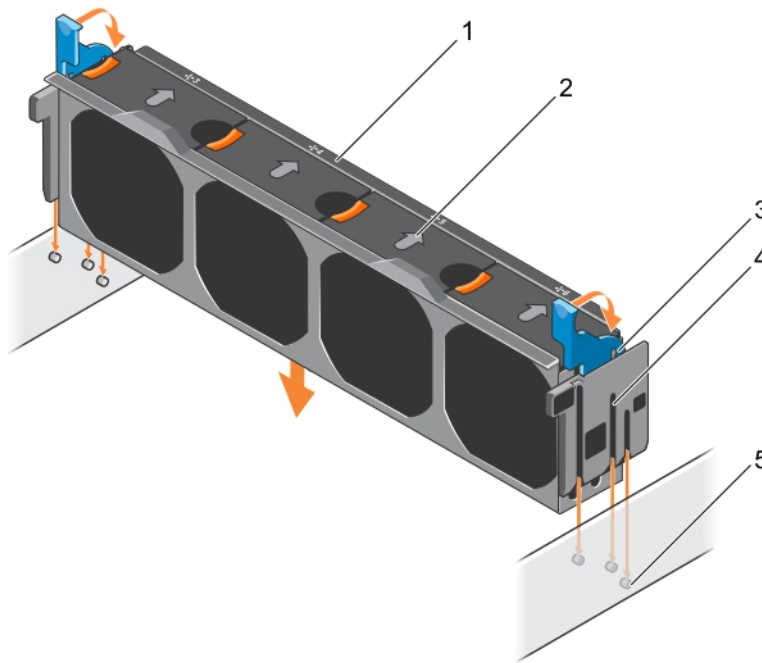

Figure 28. Installing the cooling fan assembly

- | | | | |
|---|----------------------|---|-----------------|
| 1 | cooling-fan assembly | 2 | cooling fan (4) |
| 3 | release lever (2) | 4 | slot (6) |
| 5 | guide pin (6) | | |

Related links

[Safety instructions](#)

[Removing the optional cooling fan assembly](#)

[After working inside your system](#)

System memory

The system supports DDR4 registered DIMMs (RDIMMs) and load reduced DIMMs (LRDIMMs). System memory holds the instructions that are executed by the processor.

NOTE: MT/s indicates DIMM speed in MegaTransfers per second.

Memory bus operating frequency can be 1866 MT/s, 2133 MT/s, or 2400 MT/s depending on the following factors:

- DIMM type (RDIMM or LRDIMM)
- Number of DIMMs populated per channel
- System profile selected (for example, Performance Optimized, Custom, or Dense Configuration Optimized)
- Maximum supported DIMM frequency of the processors

Your system contains 24 memory sockets split into two sets of 12 sockets, one set per processor. Each 12-socket set is organized into four channels. In each channel, the release tabs of the first socket are marked white, the second socket black, and the third socket green.

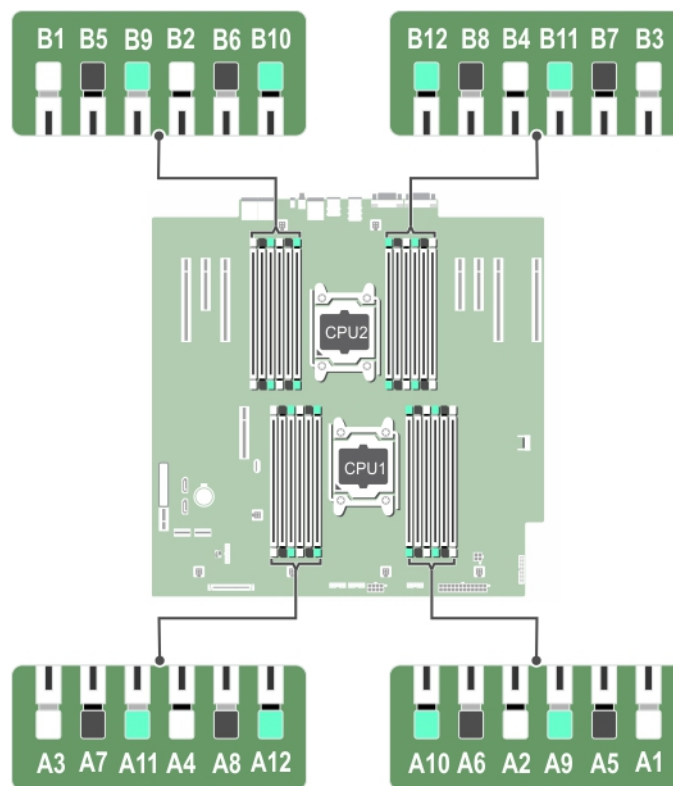

Figure 29. Memory socket locations

Memory channels are organized as follows:

Table 28. Memory channels

Processor	Channel 0	Channel 1	Channel 2	Channel 3
Processor 1	Slots A1, A5, and A9	Slots A2, A6, and A10	Slots A3, A7, and A11	Slots A4, A8, and A12
Processor 2	Slots B1, B5, and B9	Slots B2, B6, and B10	Slots B3, B7, and B11	Slots B4, B8, and B12

The following table shows the memory populations and operating frequencies for the supported configurations:

Table 29. Memory population

DIMM Type	DIMMs Populated/Channel	Voltage	Operating Frequency (in MT/s)	Maximum DIMM Rank/Channel
RDIMM	1		2400, 2133, 1866	Dual rank or single rank
	2	1.2 V	2400, 2133, 1866	Dual rank or single rank
	3		1866	Dual rank or single rank
LRDIMM	1		2400, 2133, 1866	Quad rank
	2	1.2 V	2400, 2133, 1866	Quad rank
	3		2133, 1866	Quad rank

General memory module installation guidelines

NOTE: Memory configurations that fail to observe these guidelines can prevent your system from booting, stop responding during memory configuration, or operating with reduced memory.

The system supports Flexible Memory Configuration, enabling the system to be configured and run in any valid chipset architectural configuration. The following are the recommended guidelines for installing memory modules:

- RDIMMs and LRDIMMs must not be mixed.
- x4 and x8 DRAM based memory modules can be mixed. For more information, see the Mode-specific guidelines section.
- Up to three dual- or single-rank RDIMMs can be populated per channel.
- Up to three LRDIMMs can be populated per channel regardless of rank count.
- If memory modules with different speeds are installed, they will operate at the speed of the slowest installed memory module(s) or slower depending on system DIMM configuration.
- Populate memory module sockets only if a processor is installed. For single-processor systems, sockets A1 to A12 are available. For dual-processor systems, sockets A1 to A12 and sockets B1 to B12 are available.
- Populate all the sockets with white release tabs first, followed by the black release tabs, and then the green release tabs.
- When mixing memory modules with different capacities, populate the sockets with memory modules with highest capacity first. For example, if you want to mix 4 GB and 8 GB memory modules, populate 8 GB memory modules in the sockets with white release tabs and 4 GB memory modules in the sockets with black release tabs.
- In a dual-processor configuration, the memory configuration for each processor should be identical. For example, if you populate socket A1 for processor 1, then populate socket B1 for processor 2, and so on.
- Memory modules of different capacities can be mixed provided other memory population rules are followed (for example, 4 GB and 8 GB memory modules can be mixed).
- Mixing of more than two memory module capacities in a system is not supported.
- Populate four memory modules per processor (one DIMM per channel) at a time to maximize performance.

Mode-specific guidelines

Four memory channels are allocated to each processor. The allowable configurations depend on the memory mode selected.

Advanced Error Correction Code (lockstep)

Advanced Error Correction Code (ECC) mode extends SDDC from x4 DRAM based DIMMs to both x4 and x8 DRAMs. This protects against single DRAM chip failures during normal operation.

The installation guidelines for memory modules are as follows:

- Memory modules must be identical in size, speed, and technology.
- DIMMs installed in memory sockets with white release levers must be identical and the same rule applies for sockets with black release levers. This ensures that identical DIMMs are installed in matched pair—for example, A1 with A2, A3 with A4, A5 with A6, and so on.

Memory optimized (independent channel) mode

This mode supports Single Device Data Correction (SDDC) only for memory modules that use x4 device width. It does not impose any specific slot population requirements.

Memory sparing

NOTE: To use memory sparing, this feature must be enabled in System Setup.

In this mode, one rank per channel is reserved as a spare. If persistent correctable errors are detected on a rank, the data from this rank is copied to the spare rank, and the failed rank is disabled.

With memory sparing enabled, the system memory available to the operating system is reduced by one rank per channel. For example, in a dual-processor configuration with sixteen 4 GB single-rank memory modules, the available system memory is: $3/4$ (ranks/channel) \times 16 (memory modules) \times 4 GB = 48 GB, and not 16 (memory modules) \times 4 GB = 64 GB.

NOTE: Memory sparing does not offer protection against a multi-bit uncorrectable error.

NOTE: Both Advanced ECC/Lockstep and Optimizer modes support memory sparing.

Memory mirroring

Memory mirroring offers the strongest memory module reliability mode compared to all other modes, providing improved uncorrectable multi-bit failure protection. In a mirrored configuration, the total available system memory is one half of the total installed physical memory. Half of the installed memory is used to mirror the active memory modules. In the event of an uncorrectable error, the system switches over to the mirrored copy. This ensures SDDC and multi-bit protection.

The installation guidelines for memory modules are as follows:

- Memory modules must be identical in size, speed, and technology.
- Memory modules installed in memory module sockets with white release levers must be identical and the same rule applies for sockets with black and green release tabs. This ensures that identical memory modules are installed in matched pairs—for example, A1 with A2, A3 with A4, A5 with A6, and so on.

Table 30. Processor configuration

Processor	Configuration	Memory population rules	Memory population information
Single CPU	Memory population order	{1,2}, {3,4}	See Memory mirroring note

Sample memory configurations

The following tables show sample memory configurations for one and two processor configurations that follow the appropriate memory guidelines.

NOTE: 1R, 2R, and 4R in the following tables indicate single, dual, and quad-rank DIMMs respectively.

Table 31. Memory configurations—single processor

System capacity (in GB)	DIMM size (in GB)	Number of DIMMs	DIMM rank, organization, and frequency	DIMM slot population
4	4	1	1R, x8, 2400 MT/s	A1
			1R, x8, 2133 MT/s	
8	4	2	1R, x8, 2400 MT/s	A1, A2
			1R, x8, 2133 MT/s	
16	4	4	1R, x8, 2400 MT/s	A1, A2, A3, A4
			1R, x8, 2133 MT/s	
	8	2	1R, x8, 2400 MT/s	A1, A2
			1R, x8, 2133 MT/s	
24	4	6	1R, x8, 2400 MT/s	A1, A2, A3, A4, A5, A6
			1R, x8, 2133 MT/s	
48	4	12	1R, x8, 1866 MT/s	A1, A2, A3, A4, A5, A6, A7, A8, A9, A10, A11, A12
			1R, x8, 2133 MT/s	
	8	6	1R, x8, 2400 MT/s	A1, A2, A3, A4, A5, A6
			1R, x8, 2133 MT/s	
96	8	12	1R, x8, 1866 MT/s	A1, A2, A3, A4, A5, A6, A7, A8, A9, A10, A11, A12
			2R, x8, 2400 MT/s	
	16	6	2R, x8, 2133 MT/s	A1, A2, A3, A4, A5, A6
			2R, x8, 2133 MT/s	
128	16	8	2R, x8, 2400 MT/s	A1, A2, A3, A4, A5, A6, A7, A8
			2R, x8, 2133 MT/s	
144	8	10	1R, x8, 1866 MT/s	A1, A2, A3, A4, A5, A6, A7, A8, A9, A11*
			2R, x8, 1866 MT/s	
	16	10	2R, x8, 1866 MT/s	A1, A2, A3, A4, A5, A6, A7, A8, A9, A11*
			2R, x8, 1866 MT/s	
256	32	8	2R, x4, 2400 MT/s	A1, A2, A3, A4, A5, A6, A7, A8

System capacity (in GB)	DIMM size (in GB)	Number of DIMMs	DIMM rank, organization, and frequency	DIMM slot population
			2R, x4, 2133 MT/s	
384	32	12	2R, x4, 1866 MT/s	A1, A2, A3, A4, A5, A6, A7, A8, A9, A10, A11, A12
512	64	8	4R, x4, 2133 MT/s	A1, A2, A3, A4, A5, A6, A7, A8
			4R, x4, 2400 MT/s	
768	64	12	4R, x4, 1866 MT/s	A1, A2, A3, A4, A5, A6, A7, A8, A9, A10, A11, A12
			4R, x4, 2133 MT/s	

* 16 GB DIMMs must be installed in slots numbered A1, A2, A3, A4, A5, A6, A7, and A8 and 8 GB DIMMs must be installed in slots A9 and A11.

Table 32. Memory configurations—two processors

System capacity (in GB)	DIMM size (in GB)	Number of DIMMs	DIMM rank, organization, and frequency	DIMM slot population
16	4	4	1R, x8, 2400 MT/s	A1, A2, B1, B2
			1R, x8, 2133 MT/s	
32	4	8	1R, x8, 2400 MT/s	A1, A2, A3, A4, B1, B2, B3, B4
			1R, x8, 2133 MT/s	
64	4	16	1R, x8, 2400 MT/s	A1, A2, A3, A4, A5, A6, A7, A8, B1, B2, B3, B4, B5, B6, B7, B8
			1R, x8, 2133 MT/s	
	8	8	1R, x8, 2400 MT/s	A1, A2, A3, A4, B1, B2, B3, B4
			1R, x8, 2133 MT/s	
96	4	24	1R, x8, 1866 MT/s	A1, A2, A3, A4, A5, A6, A7, A8, A9, A10, A11, A12, B1, B2, B3, B4, B5, B6, B7, B8, B9, B10, B11, B12
	8	12	1R, x8, 2400 MT/s	A1, A2, A3, A4, A5, A6, B1, B2, B3, B4, B5, B6
			1R, x8, 2133 MT/s	
128	8	16	1R, x8, 2400 MT/s	A1, A2, A3, A4, A5, A6, A7, A8, B1, B2, B3, B4, B5, B6, B7, B8
			1R, x8, 2133 MT/s	
	16	8	2R, x8, 2400 MT/s	A1, A2, A3, A4, B1, B2, B3, B4
			2R, x8, 2133 MT/s	
160	8	20	1R, x8, 1866 MT/s	A1, A2, A3, A4, A5, A6, A7, A8, A9, A11, B1, B2, B3, B4, B5, B6, B7, B8, B9, B11

System capacity (in GB)	DIMM size (in GB)	Number of DIMMs	DIMM rank, organization, and frequency	DIMM slot population
	8	12	1R, x8, 2400 MT/s 1R, x8, 2133 MT/s	A1, A2, A3, A4, A5, A6, B1, B2, B3, B4, B5, B6 *
	16	12	2R, x8, 2400 MT/s 2R, x8, 2133 MT/s	A1, A2, A3, A4, A5, A6, B1, B2, B3, B4, B5, B6 *
192	8	24	1R, x8, 1866 MT/s	A1, A2, A3, A4, A5, A6, A7, A8, A9, A10, A11, A12, B1, B2, B3, B4, B5, B6, B7, B8, B9, B10, B11, B12
	16	12	2R, x8, 2400 MT/s 2R, x8, 2133 MT/s	A1, A2, A3, A4, A5, A6, B1, B2, B3, B4, B5, B6
256	16	16	2R, x8, 2400 MT/s 2R, x8, 2133 MT/s	A1, A2, A3, A4, A5, A6, A7, A8, B1, B2, B3, B4, B5, B6, B7, B8
384	16	24	2R, x8, 1866 MT/s	A1, A2, A3, A4, A5, A6, A7, A8, A9, A10, A11, A12, B1, B2, B3, B4, B5, B6, B7, B8, B9, B10, B11, B12
	32	12	2R, x4, 2400 MT/s 2R, x4, 2133 MT/s	A1, A2, A3, A4, A5, A6, B1, B2, B3, B4, B5, B6
512	32	16	2R, x4, 2400 MT/s 2R, x4, 2133 MT/s	A1, A2, A3, A4, A5, A6, A7, A8, B1, B2, B3, B4, B5, B6, B7, B8
	64	8	4R, x4, 2400 MT/s 4R, x4, 2133 MT/s	A1, A2, A3, A4, A5, A6, A7, A8, B1, B2, B3, B4, B5, B6, B7, B8
768	32	24	2R, x4, 1866 MT/s	A1, A2, A3, A4, A5, A6, A7, A8, A9, A10, A11, A12, B1, B2, B3, B4, B5, B6, B7, B8, B9, B10, B11, B12
	64	16	4R, x4, 2400 MT/s 4R, x4, 2133 MT/s	A1, A2, A3, A4, A5, A6, A7, A8, A9, A10, A11, A12, B1, B2, B3, B4, B5, B6
1024	64	16	4R, x4, 2133 MT/s	A1, A2, A3, A4, A5, A6, A7, A8, A9, A10, A11, A12, B1, B2, B3, B4, B5, B6
1536	64	24	4R, x4, 1866 MT/s 4R, x4, 2133 MT/s	A1, A2, A3, A4, A5, A6, A7, A8, A9, A10, A11, A12, B1, B2, B3, B4, B5, B6, B7, B8, B9, B10, B11, B12

* 16 GB DIMMs must be installed in slots numbered A1, A2, A3, A4, B1, B2, B3, and B4 and 8 GB DIMMs must be installed in slots A5, A6, B5, and B6.

Removing memory modules

Prerequisites

CAUTION: Many repairs may only be done by a certified service technician. You should only perform troubleshooting and simple repairs as authorized in your product documentation, or as directed by the online or telephone service and support team. Damage due to servicing that is not authorized by Dell is not covered by your warranty. Read and follow the safety instructions that are shipped with your product.

- 1 Follow the safety guidelines listed in the Safety instructions section.
- 2 Follow the procedure listed in the Before working inside your system section.
- 3 Remove the cooling shroud.
- 4 If installed, remove the cooling fan assembly. For more information, see the Removing the cooling-fan assembly section.

WARNING: The memory modules are hot to touch for some time after the system has been powered down. Allow the memory modules to cool before handling them. Handle the memory modules by the card edges and avoid touching the components or metallic contacts on the memory module.

CAUTION: To ensure proper system cooling, memory module blanks must be installed in any memory socket that is not occupied. Remove memory module blanks only if you intend to install memory modules in those sockets.

Steps

- 1 Locate the appropriate memory module socket.

CAUTION: Handle each memory module only by the card edges, ensuring not to touch the middle of the memory module or metallic contacts.

- 2 To release the memory module from the socket, simultaneously press the ejectors on both ends of the memory module socket.
- 3 Lift and remove the memory module from the system.

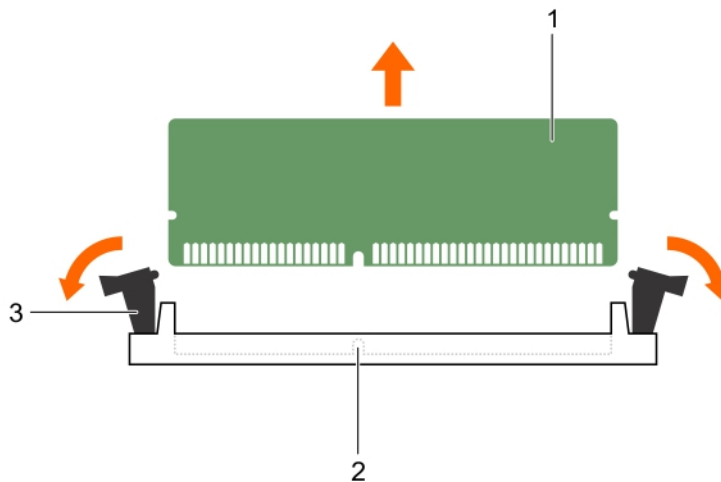

Figure 30. Removing the memory module

- | | | | |
|---|----------------------------------|---|----------------------|
| 1 | memory module | 2 | memory module socket |
| 3 | memory module socket ejector (2) | | |

Next steps

- 1 If you are removing the memory module permanently, install a memory-module blank.
- 2 Install the memory module.
- 3 Install the cooling shroud.
- 4 Follow the procedure listed in the After working inside your system section.

Related links

- [Safety instructions](#)
- [Before working inside your system](#)
- [Removing the optional cooling fan assembly](#)
- [Installing memory modules](#)

Installing memory modules

Prerequisites

CAUTION: Many repairs may only be done by a certified service technician. You should only perform troubleshooting and simple repairs as authorized in your product documentation, or as directed by the online or telephone service and support team. Damage due to servicing that is not authorized by Dell is not covered by your warranty. Read and follow the safety instructions that are shipped with your product.

- 1 Follow the safety guidelines listed in the Safety instructions section.
- 2 Follow the procedure listed in the Before working inside your system section.
- 3 Removing the cooling fan assembly.

WARNING: The memory modules are hot to touch for some time after the system has been powered down. Allow the memory modules to cool before handling them. Handle the memory modules by the card edges and avoid touching the components or metallic contacts on the memory module.

Steps

- 1 Locate the appropriate memory module socket.

CAUTION: Handle each memory module only by the card edges, ensuring not to touch the middle of the memory module or metallic contacts.

- 2 Align the edge connector of the memory module with the alignment key of the memory module socket, and insert the memory module in the socket.

CAUTION: Do not apply pressure at the center of the memory module; apply pressure at both ends of the memory module evenly.

NOTE: The memory module socket has an alignment key that enables you to install the memory module in the socket in only one orientation.

- 3 Press the memory module with your thumbs until the socket levers firmly click into place.

When the memory module is properly seated in the socket, the levers on the memory module socket align with the levers on the other sockets that have memory modules installed.

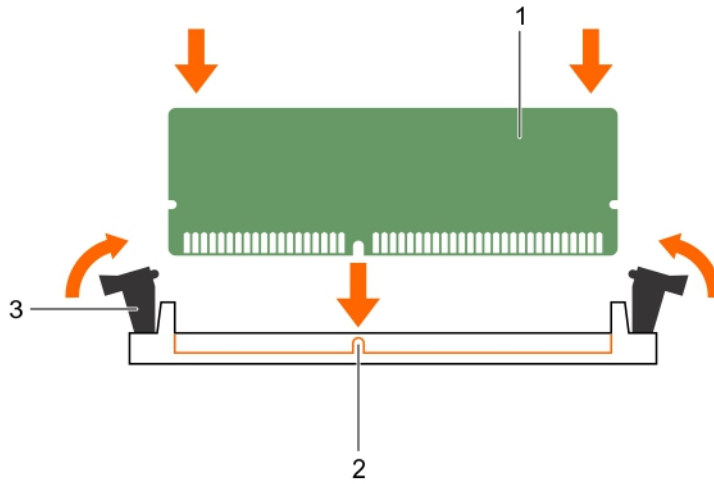

Figure 31. Installing the memory module

- | | | | |
|---|----------------------------------|---|---------------|
| 1 | memory module | 2 | alignment key |
| 3 | memory module socket ejector (2) | | |

Next steps

- 1 Follow the procedure listed in the After working inside your system section.
- 2 Press F2 to enter System Setup, and check the **System Memory** setting.
The system should have already changed the value to reflect the installed memory.
- 3 If the value is incorrect, one or more of the memory modules may not be installed properly. Ensure that the memory module is firmly seated in the memory module socket.
- 4 Run the system memory test in system diagnostics.

Related links

- [Safety instructions](#)
- [Before working inside your system](#)
- [After working inside your system](#)
- [Removing memory modules](#)
- [Removing the optional cooling fan assembly](#)

Flex bays

Your system's flex bay supports sixteen 2.5 inch hard drives or four Dell PowerEdge Express Flash devices.

Removing a flex bay

Prerequisites

- 1 Follow the safety guidelines listed in the safety instructions section.
- 2 Keep the Phillips #2 screwdriver ready.
- 3 Follow the procedure listed in the Before working inside your system section.

CAUTION: Many repairs may only be done by a certified service technician. You should only perform troubleshooting and simple repairs as authorized in your product documentation, or as directed by the online or telephone service and support team. Damage due to servicing that is not authorized by Dell is not covered by your warranty. Read and follow the safety instructions that are shipped with your product.

Steps

- 1 Remove the cables.
 - a For a 2.5 inch drive flex bay, remove the cables from the slim optical-drive and the backplane.
 - b For a Dell PowerEdge Express Flash device flex bay, remove the cables from the backplane.
- 2 Remove the two screws that secure the flex bay to the chassis.
- 3 Press the release latch and pull the flex bay away from the chassis.

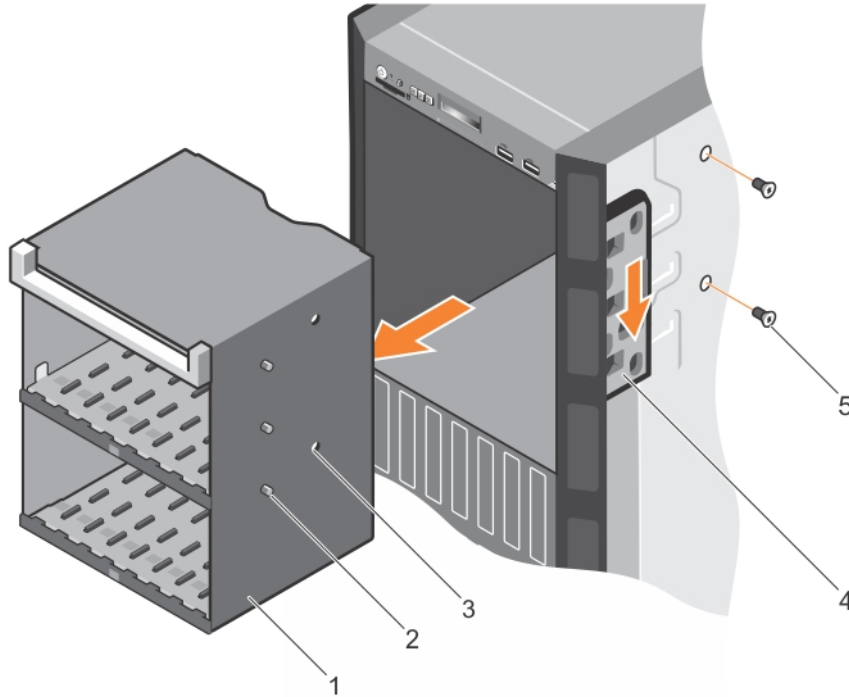

Figure 32. Removing a flex bay

- | | | | |
|---|----------------|---|---------------|
| 1 | flex bay | 2 | tab (3) |
| 3 | screw hole (2) | 4 | release latch |
| 5 | screw (2) | | |

Related links

- [Safety instructions](#)
- [Before working inside your system](#)
- [Installing a flex bay](#)

Installing a flex bay

Prerequisites

- 1 Follow the safety guidelines listed in the safety instructions section.
- 2 Keep the Phillips #2 screwdriver ready.

CAUTION: Many repairs may only be done by a certified service technician. You should only perform troubleshooting and simple repairs as authorized in your product documentation, or as directed by the online or telephone service and support team. Damage due to servicing that is not authorized by Dell is not covered by your warranty. Read and follow the safety instructions that are shipped with your product.

Steps

- 1 Align the tabs on the flex bay with the slots on the front of the chassis.
- 2 Insert the flex bay into the chassis until the tabs click into place.
- 3 Install the two screws to secure the flex bay to the chassis.

Next step

Follow the procedure listed in the After working inside your system section.

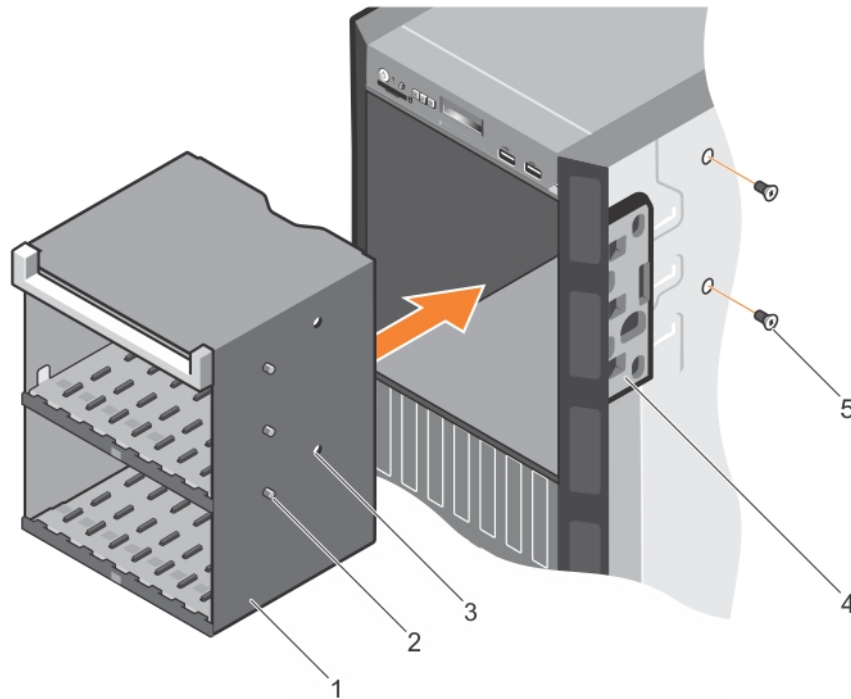

Figure 33. Installing a flex bay

- | | | | |
|---|----------------|---|---------------|
| 1 | flex bay | 2 | tab (3) |
| 3 | screw hole (2) | 4 | release latch |
| 5 | screw (2) | | |

Related links

- [Safety instructions](#)
- [After working inside your system](#)
- [Removing a flex bay](#)

Hard drives

Your system supports entry hard drives and enterprise-class hard drives. Entry hard drives are designed for 5x8 operating environment with less workload rating to drives and enterprise-class drives are designed for 24x7 operating environment. Selecting the correct drive class will enable the critical areas of quality, functionality, performance, and reliability to be optimized for the target implementation.

NOTE: Do not mix enterprise-class hard drives with entry hard drives.

Choosing the right drive type depends on the usage pattern. Improper use of entry hard drives (workload rating exceeds 55TB/year) will lead to significant risk and increase the drives failure rate.

For more information on these hard drives, see the *512e and 4Kn Disk Formats* whitepaper and *4K Sector HDD FAQ* document at Dell.com/poweredge manuals.

All hard drives are connected to the system board through the hard drive backplane. Hard drives are supplied in hot-swappable hard drive carriers that fit in the hard drive slots.

CAUTION: Before attempting to remove or install a hard drive while the system is running, see the documentation for the storage controller card to ensure that the host adapter is configured correctly to support hot-swap hard drive removal and insertion.

CAUTION: Do not turn off or restart your system while the hard drive is being formatted. Doing so can cause a hard drive failure.

Use only hard drives that have been tested and approved for use with the hard drive backplane.

When you format a hard drive, allow enough time for the formatting to be complete. Be aware that high-capacity hard drives can take a long time to format.

Removing a hot swappable hard drive or SSD

Prerequisites

CAUTION: Many repairs may only be done by a certified service technician. You should only perform troubleshooting and simple repairs as authorized in your product documentation, or as directed by the online or telephone service and support team. Damage due to servicing that is not authorized by Dell is not covered by your warranty. Read and follow the safety instructions that came with the product.

- 1 Follow the safety guidelines listed in the Safety instructions section.
- 2 Follow the procedure listed in the Before working inside your system section.
- 3 If applicable, remove the bezel.
- 4 Using the management software, prepare the hard drive for removal. If the hard drive is online, the green activity or fault indicator flashes while the drive is turning off. When the hard drive indicators are off, the hard drive is ready for removal.

For more information, see the documentation for the storage controller.

CAUTION: To prevent data loss, ensure that your operating system supports hot-swap drive installation. See the documentation supplied with your operating system.

Steps

- 1 Press the release button to open the hard drive or SSD carrier release handle.
- 2 Slide the hard drive carrier or SSD out of the hard drive slot.

CAUTION: To maintain proper system cooling, all empty hard drive or SSD slots must have hard drive or SSD blanks installed.

- 3 If you are not replacing the hard drive or SSD immediately, insert a hard drive or SSD blank in the empty hard drive slot.

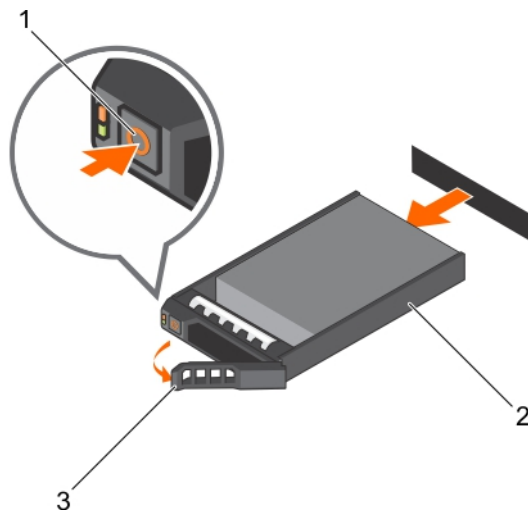

Figure 34. Removing a hot swappable hard drive or SSD

- 1 release button
- 2 hard drive or SSD carrier
- 3 hard drive or SSD carrier handle

Related links

- [Safety instructions](#)
- [Before working inside your system](#)
- [After working inside your system](#)
- [Removing the optional front bezel](#)

Installing a hot swappable hard drive

Prerequisites

- ⚠ **CAUTION:** Many repairs may only be done by a certified service technician. You should only perform troubleshooting and simple repairs as authorized in your product documentation, or as directed by the online or telephone service and support team. Damage due to servicing that is not authorized by Dell is not covered by your warranty. Read and follow the safety instructions that are shipped with your product.
- ⚠ **CAUTION:** Use only hard drives that have been tested and approved for use with the hard drive backplane.
- ⚠ **CAUTION:** Combining SAS and SATA hard drives in the same RAID volume is not supported.
- ⚠ **CAUTION:** When installing a hard drive, ensure that the adjacent drives are fully installed. Inserting a hard drive carrier and attempting to lock its handle next to a partially installed carrier can damage the partially installed carrier's shield spring and make it unusable.
- ⚠ **CAUTION:** To prevent data loss, ensure that your operating system supports hot-swap drive installation. See the documentation supplied with your operating system.
- ⚠ **CAUTION:** When a replacement hot swappable hard drive is installed and the system is powered on, the hard drive automatically begins to rebuild. Make absolutely sure that the replacement hard drive is blank or contains data that you wish to have overwritten. Any data on the replacement hard drive is immediately lost after the hard drive is installed.

- 1 Follow the safety guidelines listed in Safety instructions section.

Steps

- 1 If a hard drive blank is installed in the hard drive slot, remove it.
- 2 Install a hard drive in the hard drive carrier. For more information, see the Installing a hot swappable hard drive into a hot swappable hard drive carrier section.

- 3 Press the release button on the front of the hard drive carrier and open the hard drive carrier handle.
- 4 Insert the hard drive carrier into the hard drive slot until the carrier connects with the backplane.
- 5 Close the hard drive carrier handle to lock the hard drive in place.

Next step

Install the optional front bezel.

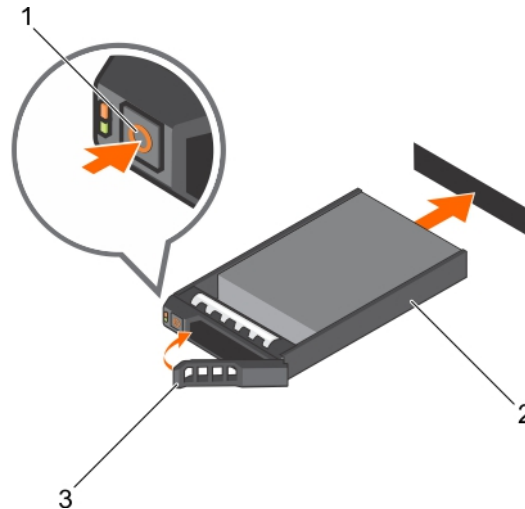

Figure 35. Installing a hot swappable hard drive

- | | | | |
|---|----------------------------------|---|---------------------------|
| 1 | release button | 2 | hard drive or SSD carrier |
| 3 | hard drive or SSD carrier handle | | |

Related link

[Safety instructions](#)

Removing a 2.5-inch hard drive blank

Prerequisites

⚠ CAUTION: Many repairs may only be done by a certified service technician. Perform troubleshooting and simple repairs as authorized in your product documentation, or as directed by the online or telephone service and support team. Damage due to servicing that is not authorized by Dell is not covered by your warranty. Read and follow the safety instructions that came with the product.

⚠ CAUTION: To maintain proper system cooling, all empty hard drive slots must have hard drive blanks installed.

- 1 Follow the safety guidelines listed in the Safety instructions section.
- 2 If installed, remove the bezel.

Step

Press the release button and slide the hard drive blank out of the hard drive slot.

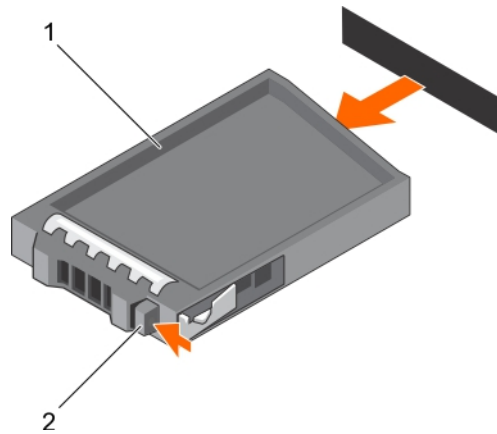

Figure 36. Removing a 2.5-inch hard drive blank

1 hard drive blank

2 release button

Related links

[Safety instructions](#)

[Installing a 2.5-inch hard drive blank](#)

Installing a 2.5-inch hard drive blank

Prerequisites

- 1 Follow the safety guidelines listed in the Safety instructions section.
- 2 If installed, remove the front bezel.

Step

Insert the hard drive blank into the hard drive slot until the release button clicks into place.

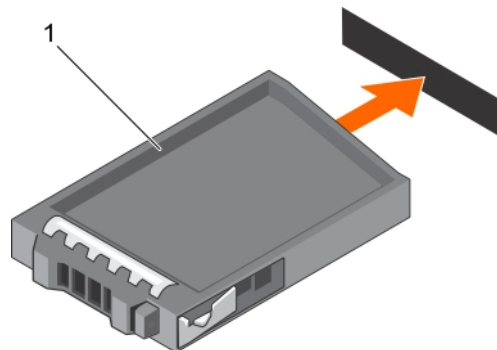

Figure 37. Installing a 2.5-inch hard drive blank

1 hard drive blank

Next step

If removed, install the front bezel.

Related links

[Safety instructions](#)

[Removing a 2.5-inch hard drive blank](#)

Removing a 3.5-inch hard drive blank

Prerequisites

CAUTION: Many repairs may only be done by a certified service technician. You should only perform troubleshooting and simple repairs as authorized in your product documentation, or as directed by the online or telephone service and support team. Damage due to servicing that is not authorized by Dell is not covered by your warranty. Read and follow the safety instructions that came with the product.

CAUTION: To maintain proper system cooling, all empty hard drive slots must have hard drive blanks installed.

- 1 Follow the safety guidelines listed in the Safety instructions section.
- 2 If installed, remove the front bezel.

Step

Press the release button and slide the blank out of the hard drive slot.

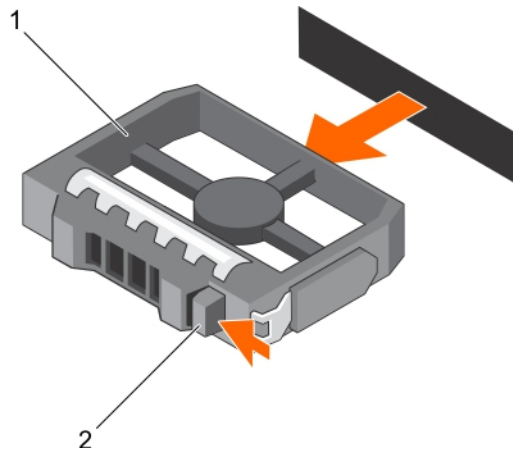

Figure 38. Removing a 3.5 inch hard drive blank

1 hard drive blank

2 release button

Next step

If applicable, install the front bezel.

Related links

[Safety instructions](#)

[Installing the optional front bezel](#)

[Installing a 3.5-inch hard drive blank](#)

[Safety instructions](#)

Installing a 3.5-inch hard drive blank

Prerequisites

- 1 Follow the safety guidelines listed in the Safety instructions section.
- 2 If installed, remove the front bezel.

Step

Insert the hard drive blank into the hard drive slot until the release button clicks into place.

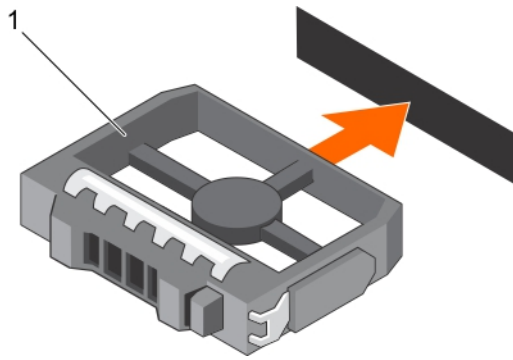

Figure 39. Installing a 3.5 inch hard drive blank

- 1 hard drive blank

Next step

If applicable, install the front bezel.

Related link

[Safety instructions](#)

Installing a hot swappable 2.5-inch hard drive into a 3.5-inch hard drive adapter

Prerequisites

⚠ CAUTION: Many repairs may only be done by a certified service technician. You should only perform troubleshooting and simple repairs as authorized in your product documentation, or as directed by the online or telephone service and support team. Damage due to servicing that is not authorized by Dell is not covered by your warranty. Read and follow the safety instructions that are shipped with your product.

- 1 Follow the safety guidelines listed in the Safety instructions section.
- 2 Keep the #2 Phillips screwdriver ready.

Steps

- 1 Align the screw holes on the 2.5-inch hot swappable hard drive with the screw holes on the 3.5-inch hard drive adapter.
- 2 Install the screws to secure the hot swappable hard drive to the 3.5-inch hard drive adapter.

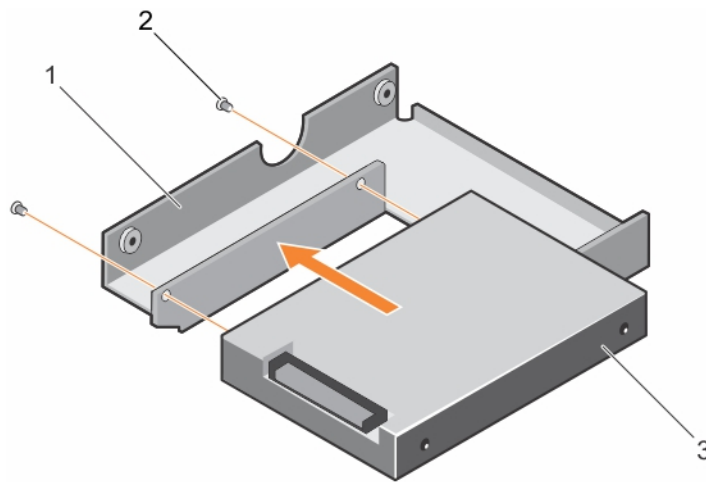

Figure 40. Installing a 2.5-inch hot swappable hard drive into a 3.5-inch hard drive adapter

- | | | | |
|---|-----------------------------|---|-----------|
| 1 | 3.5-inch hard drive adapter | 2 | screw (2) |
| 3 | 2.5-inch hard drive | | |

Next step

Install the 3.5-inch adapter into the 3.5-inch hard drive carrier.

Related links

[Safety instructions](#)

[Removing a 2.5-inch hot swappable hard drive from a 3.5-inch hard drive adapter](#)

Removing a 2.5-inch hot swappable hard drive from a 3.5-inch hard drive adapter

Prerequisites

⚠ CAUTION: Many repairs may only be done by a certified service technician. You should only perform troubleshooting and simple repairs as authorized in your product documentation, or as directed by the online or telephone service and support team. Damage due to servicing that is not authorized by Dell is not covered by your warranty. Read and follow the safety instructions that came with the product.

- 1 Follow the safety guidelines listed in the Safety instructions section.
- 2 Keep the Phillips #2 screwdriver ready.
- 3 Remove the 3.5-inch hard drive adapter from the 3.5-inch hot swappable hard drive carrier.

ⓘ NOTE: A 2.5-inch hot swappable hard drive is installed in a 3.5-inch hard drive adapter, which is then installed in the 3.5-inch hot swappable hard drive carrier.

Steps

- 1 Remove the screws from the side of the 3.5-inch hard drive adapter.
- 2 Remove the hot swappable hard drive from the 3.5-inch hard drive adapter.

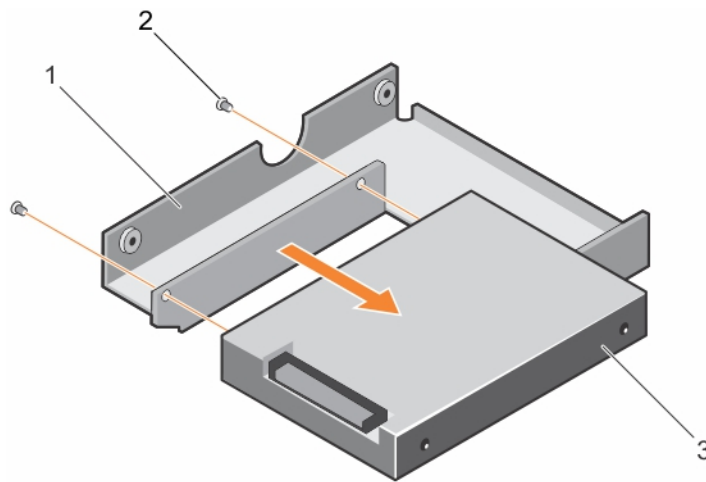

Figure 41. Removing a 2.5-inch hot swappable hard drive into a 3.5-inch hard drive adapter

- | | | | |
|---|-----------------------------------|---|-----------|
| 1 | 3.5-inch hard drive adapter | 2 | screw (2) |
| 3 | 2.5-inch hot swappable hard drive | | |

Related links

[Safety instructions](#)

[Installing a hot swappable 2.5-inch hard drive into a 3.5-inch hard drive adapter](#)

Installing a 3.5-inch hard drive adapter into a hot swap hard drive carrier

Prerequisites

⚠ CAUTION: Many repairs may only be done by a certified service technician. You should only perform troubleshooting and simple repairs as authorized in your product documentation, or as directed by the online or telephone service and support team. Damage due to servicing that is not authorized by Dell is not covered by your warranty. Read and follow the safety instructions that are shipped with your product.

- 1 Follow the safety guidelines listed in the Safety instructions section.
- 2 Keep the Phillips #2 screwdriver ready.
- 3 Install the 2.5-inch hot swappable hard drive into the hot swappable hard drive adapter.

Steps

- 1 Insert the 3.5 inch hard drive adapter into the hot swappable hard drive carrier with the connector end of the hard drive toward the back of the hot swappable hard drive carrier.
- 2 Align the screw holes on the hard drive with the holes on the hot swappable hard drive carrier.
- 3 Install the screws to secure the hot swappable hard drive to the hot swappable hard drive carrier.

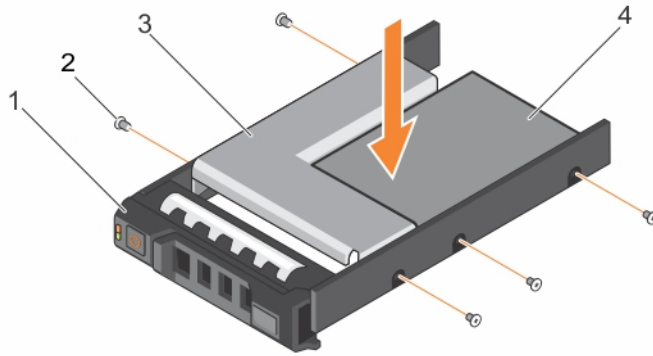

Figure 42. Installing a 3.5-inch hard drive adapter into a hot swappable hard drive carrier

- | | | | |
|---|-----------------------------|---|---------------------|
| 1 | 3.5-inch hard drive carrier | 2 | screw (5) |
| 3 | hard-drive adapter | 4 | 2.5-inch hard drive |

Next step

Install the hot swappable hard drive carrier into the system.

Related links

[Safety instructions](#)

[Removing a 3.5-inch hot swappable hard drive adapter from a 3.5-inch hot swappable hard drive carrier](#)

Removing a 3.5-inch hot swappable hard drive adapter from a 3.5-inch hot swappable hard drive carrier

- 1 Follow the safety guidelines listed in the Safety instructions section.
- 2 Keep the Phillips #2 screwdriver ready.
- 3 Remove the 3.5-inch hot swappable hard drive carrier from the system.
- 4 Remove the screws from the rails on the hot swappable hard drive carrier.
- 5 Lift the 3.5-inch hard drive adapter out of the 3.5-inch hot swappable hard drive carrier

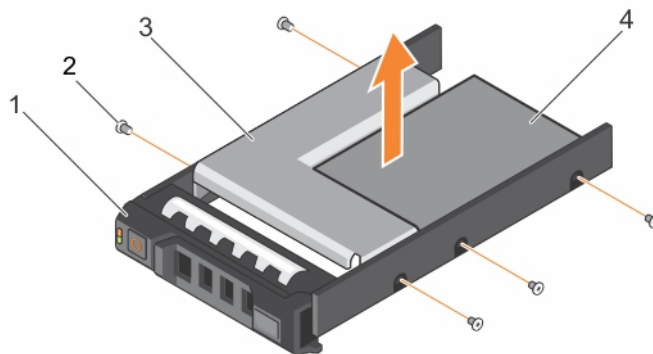

Figure 43. Removing a 3.5-inch hot swappable hard drive adapter from a 3.5-inch hot swappable hard drive carrier

- | | | | |
|---|-----------------------------|---|---------------------|
| 1 | 3.5 inch hard-drive carrier | 2 | screw (5) |
| 3 | hard drive adapter | 4 | 2.5-inch hard drive |

Related links

[Safety instructions](#)

[Installing a 3.5-inch hard drive adapter into a hot swap hard drive carrier](#)

Removing a hard drive from a hard drive carrier

Prerequisites

- 1 Keep the Phillips #1 screwdriver handy.
- 2 Remove the hard drive carrier from the system.

Steps

- 1 Remove the screws from the slide rails on the hard drive carrier.
- 2 Lift the hard drive out of the hard drive carrier.

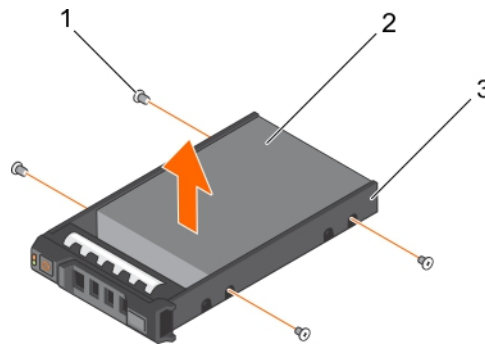

Figure 44. Removing a hard drive into a hard drive carrier

- | | | | |
|---|--------------------|---|------------|
| 1 | screw (4) | 2 | hard drive |
| 3 | hard drive carrier | | |

Related link

[Safety instructions](#)

Installing a hot swappable hard drive into a hot swappable hard drive carrier

Prerequisites

⚠ CAUTION: Many repairs may only be done by a certified service technician. You should only perform troubleshooting and simple repairs as authorized in your product documentation, or as directed by the online or telephone service and support team. Damage due to servicing that is not authorized by Dell is not covered by your warranty. Read and follow the safety instructions that are shipped with your product.

📘 NOTE: Hot swappable hard drives are supplied in hot swappable hard drive carriers that fit in the hard drive slots.

- 1 Keep the Phillips #2 screwdriver ready.
- 2 Remove the hot swappable hard drive carrier.

Steps

- 1 Insert the hot swappable hard drive into the hard drive carrier with the connector end of the hard drive toward the back.
- 2 Align the screw holes on the hard drive with the set of screw holes on the hard drive carrier.
When aligned correctly, the back of the hard drive is flush with the back of the hard drive carrier.

- 3 Attach the screws to secure the hard drive to the hard drive carrier.

Next step

Install the hard drive carrier into the system.

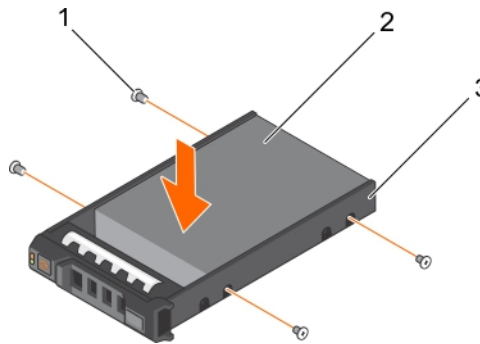

Figure 45. Installing a hot swappable hard drive into a hot swappable hard drive carrier

- | | | | |
|---|--------------------|---|------------|
| 1 | screw (4) | 2 | hard drive |
| 3 | hard drive carrier | | |

Related link

[Safety instructions](#)

Optical drives and tape drives

Your system supports one of the following configurations:

Table 33. System configurations

System	Configurations
Systems with up to eight 3.5 inch hard drives or sixteen 2.5 inch hard drives	Up to three SATA half height optical drives Up to three SATA/SAS/SCSI tape drives A combination of optical and tape drives
Systems with up to eight 3.5 inch hard drives or eight 2.5 inch hard drives in the 3.5 inch hard-drive carrier, or sixteen 2.5 inch hard drives and four PCIe SSDs	Up to one SATA half height optical drive Up to one SATA/SAS/SCSI tape drive
Systems with up to eighteen 3.5 inch hard drives	One optical or tape drive
Systems with up to thirty-two 2.5 inch hard drives	One slim optical drive with option to choose from DVD-ROM or DVD-RW. Tape drives are not supported.

Removing the optical drive or tape drive

Prerequisites

- 1 Follow the safety guidelines listed in safety instructions section.
- 2 Follow the procedure listed in Before working inside your system section.

CAUTION: Many repairs may only be done by a certified service technician. You should only perform troubleshooting and simple repairs as authorized in your product documentation, or as directed by the online or telephone service and support team. Damage due to servicing that is not authorized by Dell is not covered by your warranty. Read and follow the safety instructions that are shipped with your product.

Steps

1 Disconnect the power and data cable from the back of the drive.

NOTE: Observe the routing of the power and data cable inside the chassis as you remove them from the system board and the drive. You must route these cables properly when you replace them to prevent them from being pinched or crimped.

2 To remove the drive, push the release latch as indicated in the figure.

3 Slide the drive out of the drive bay.

4 If you are not immediately replacing the optical drive or tape drive, install the blank.

NOTE: Blanks must be installed on empty optical drive or tape drive slots to maintain FCC certification of the system. The brackets also keep dust and dirt out of the system and aid in proper cooling and airflow inside the system. Perform the same steps to install blanks.

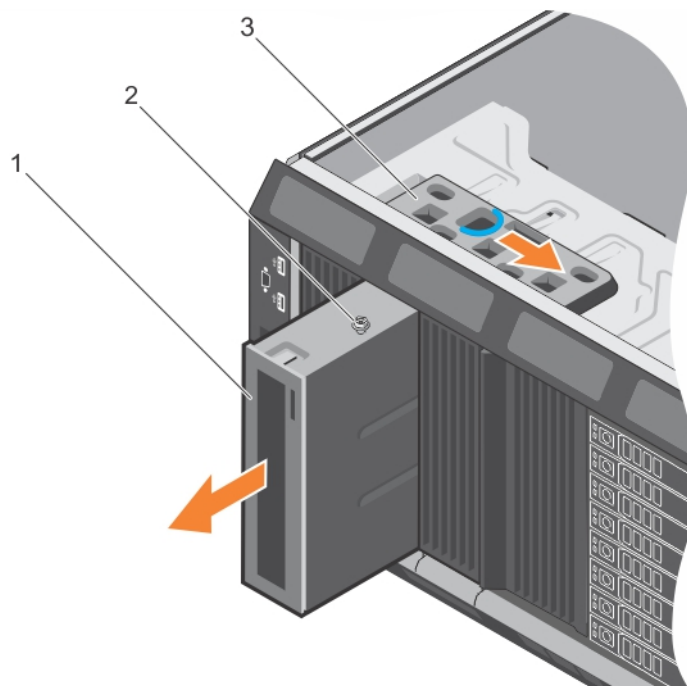

Figure 46. Removing the optical drive or tape drive

1 optical drive/tape drive

2 guide

3 release latch

NOTE: The following figure shows the cabling diagram for an optical drive/tape drive with an x16 backplane. All backplanes (x8, x18, and x16) have an ODD connector.

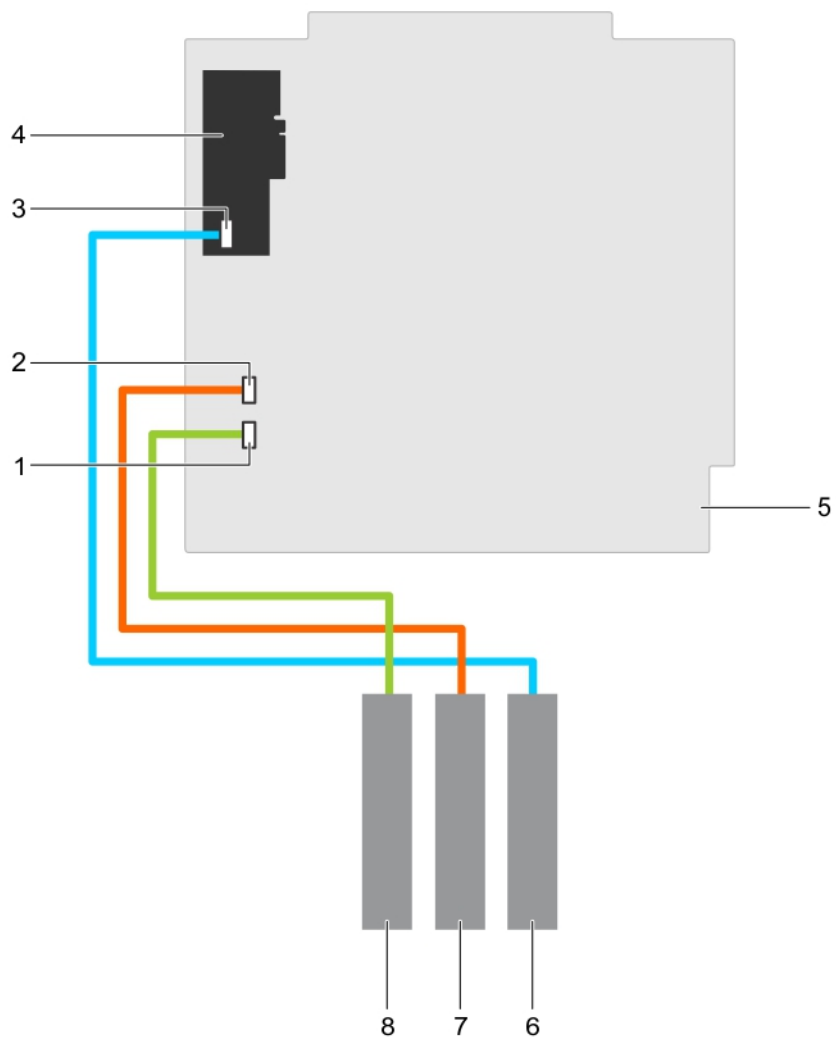

Figure 47. Cabling— optical drive and tape drive

- | | | | |
|---|--|---|------------------------------------|
| 1 | ODD1/TBU connector on system board | 2 | ODD2/TBU connector on system board |
| 3 | mini-SAS/SATA connector on internal tape adapter | 4 | internal tape adapter |
| 5 | system board | 6 | SAS tape drive |
| 7 | optical drive 2 | 8 | optical drive 1 |

Next step

Follow the procedure listed in the After working inside your system section.

Related links

- [Safety instructions](#)
- [Before working inside your system](#)
- [Installing the optical drive or tape drive](#)

Installing the optical drive or tape drive

Prerequisites

CAUTION: Many repairs may only be done by a certified service technician. You should only perform troubleshooting and simple repairs as authorized in your product documentation, or as directed by the online or telephone service and support team. Damage due to servicing that is not authorized by Dell is not covered by your warranty. Read and follow the safety instructions that are shipped with your product.

- 1 Follow the safety guidelines listed in safety instructions section.
- 2 Follow the procedure listed in Before working inside your system section.

Steps

- 1 Unpack and prepare the drive for installation.
For instructions, see the documentation that shipped with the drive.

If you are installing a SAS tape drive, you must have an internal tape adapter installed. For more information on installing a SAS tape drive, see installing an expansion card section.

- 2 If applicable, remove the old drive or the drive blank.
- 3 Align the guide on the drive with the slot on drive bay.
- 4 Slide the drive into the slot until the latch snaps into place.
- 5 Connect the power and data cable to the back of the drive.
- 6 Connect the power and data cables to the backplane and the system board.

The system board connectors are ODD1/TBU and ODD2/TBU. The system can connect up to two optical drives, or one optical drive with one SATA tape backup unit, and one SAS tape backup unit using Dell OpenManage IT Assistant.

NOTE: For systems configured with software RAID and installed with PowerVault RD1000, connect the PowerVault RD1000 data cable to ODD1/TBU (SATA_E) port and the optical drive data cable to ODD2/TBU (SATA_F) port on the system board respectively.

Next step

Follow the procedure listed in After working inside your system section.

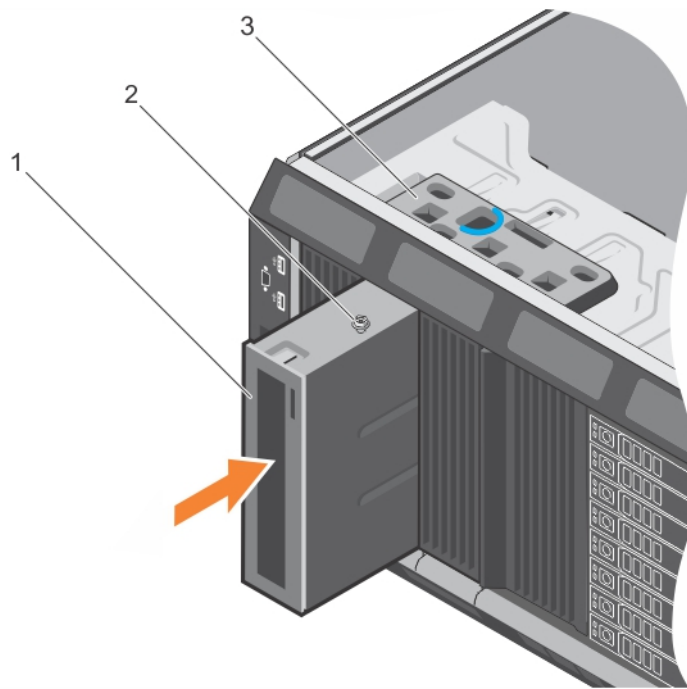

Figure 48. Installing the optical drive or tape drive

- 1 optical drive/tape drive
- 2 guide
- 3 release latch

Related links

- [Safety instructions](#)
- [Before working inside your system](#)
- [Installing an expansion card](#)
- [After working inside your system](#)

Removing the slim optical drive blank

To remove the slim optical drive, follow the same procedure.

Prerequisites

⚠ CAUTION: Many repairs may only be done by a certified service technician. You should only perform troubleshooting and simple repairs as authorized in your product documentation, or as directed by the online or telephone service and support team. Damage due to servicing that is not authorized by Dell is not covered by your warranty. Read and follow the safety instructions that are shipped with your product.

- 1 Follow the safety guidelines listed in the Safety instructions section.
- 2 Follow the procedure listed in the Before working inside your system section.

Steps

- 1 Locate the touch point for the slim optical drive blank lock inside the system.
- 2 Press the lock and pull the slim optical drive blank out of the chassis.

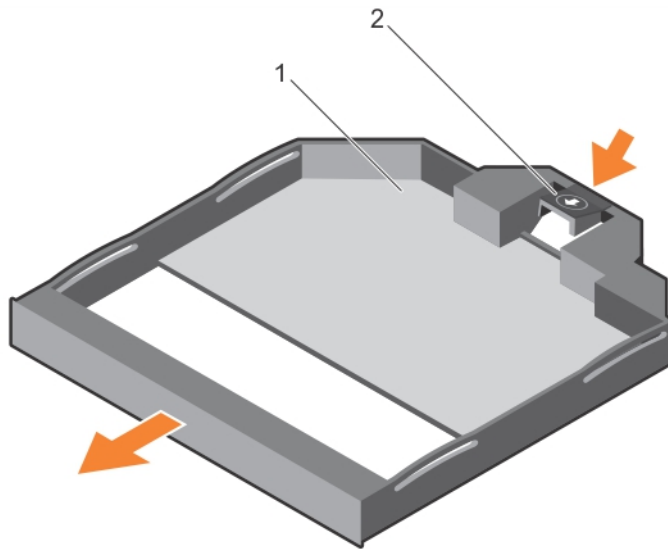

Figure 49. Removing the slim optical drive blank

1 slim optical drive blank

2 optical drive blank lock

Related links

- [Safety instructions](#)
- [Before working inside your system](#)
- [Installing the slim optical drive blank](#)

Installing the slim optical drive blank

Prerequisite

CAUTION: Many repairs may only be done by a certified service technician. You should only perform troubleshooting and simple repairs as authorized in your product documentation, or as directed by the online or telephone service and support team. Damage due to servicing that is not authorized by Dell is not covered by your warranty. Read and follow the safety instructions that are shipped with your product.

Follow the safety instructions listed in the Safety instructions section.

Steps

- 1 Align the slim optical drive blank with the slim optical drive bay.
- 2 Slide the optical drive blank into the optical drive bay until the lock clicks into place.

Next step

Follow the procedure listed in the After working inside your system section.

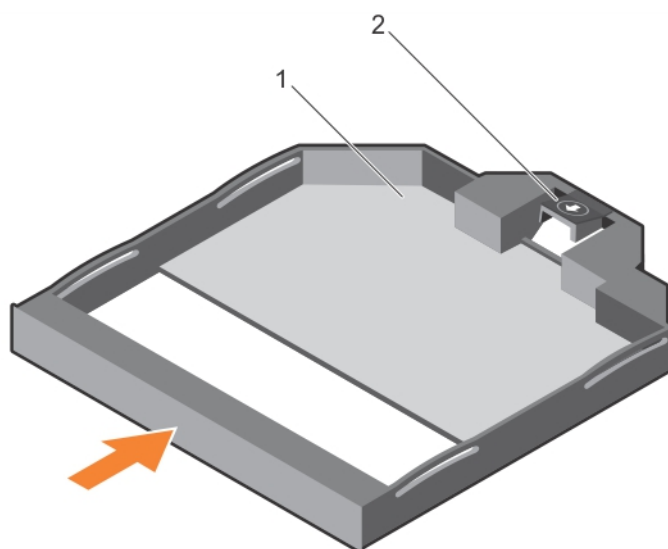

Figure 50. Installing the slim optical drive blank

1 slim optical drive blank

2 optical drive blank lock

Related links

[Safety instructions](#)

[After working inside your system](#)

[Removing the slim optical drive blank](#)

Internal USB memory key (optional)

An optional USB memory key installed inside your system can be used as a boot device, security key, or mass storage device.

To boot from the USB memory key, configure the USB memory key with a boot image and then specify the USB memory key in the boot sequence in System Setup.

The internal USB port must be enabled in **Internal USB Port** option in the **Integrated Devices** screen of **System Setup**.

NOTE: To locate the internal USB port (INT_USB) on the system board, see the **System board jumpers and connectors** section.

Replacing the optional internal USB memory key

Prerequisites

CAUTION: Many repairs may only be done by a certified service technician. You should only perform troubleshooting and simple repairs as authorized in your product documentation, or as directed by the online or telephone service and support team. Damage due to servicing that is not authorized by Dell is not covered by your warranty. Read and follow the safety instructions that are shipped with your product.

- 1 Follow the safety guidelines listed in the Safety instructions section.
- 2 Follow the procedure listed in the Before working inside your system section.

Steps

- 1 Locate the USB port or USB memory key on the system board.
To locate the USB port, see the System board jumpers and connectors section.
- 2 If installed, remove the USB memory key from the USB port.

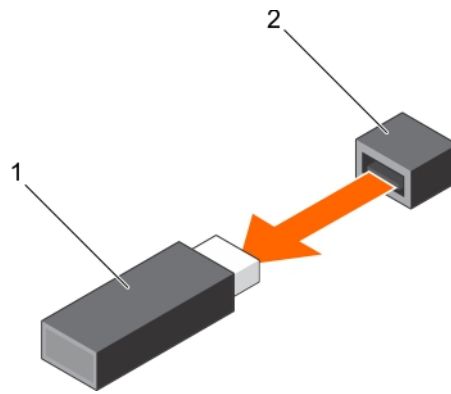

Figure 51. Removing the internal USB memory key

- 1 USB memory key
- 2 USB port
- 3 Insert the replacement USB memory key into the USB port.

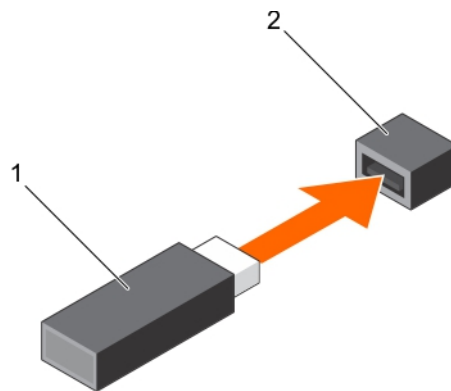

Figure 52. Installing the internal USB memory key

- 1 USB memory key
- 2 USB port

Next steps

- 1 Follow the procedure listed in the After working inside your system section.
- 2 While booting, press F2 to enter System Setup and verify that the system detects the USB memory key.

Related links

- [Safety instructions](#)
- [Before working inside your system](#)
- [After working inside your system](#)

Expansion card holder

Removing the expansion card holder

Prerequisites

- 1 Follow the safety guidelines listed in the safety instructions section.
- 2 Follow the procedure listed in the Before working inside your system section.

CAUTION: Many repairs may only be done by a certified service technician. You should only perform troubleshooting and simple repairs as authorized in your product documentation, or as directed by the online or telephone service and support team. Damage due to servicing that is not authorized by Dell is not covered by your warranty. Read and follow the safety instructions that are shipped with your product.

Step

Press the tab and pull the expansion card holder away from the chassis.

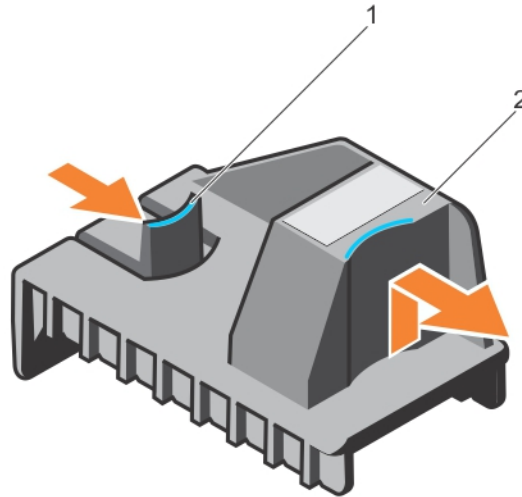

Figure 53. Removing the expansion card holder

1 tab

2 expansion card holder

Related links

- [Safety instructions](#)
- [Before working inside your system](#)
- [Installing the expansion card holder](#)

Installing the expansion card holder

Prerequisite

CAUTION: Many repairs may only be done by a certified service technician. You should only perform troubleshooting and simple repairs as authorized in your product documentation, or as directed by the online or telephone service and support team. Damage due to servicing that is not authorized by Dell is not covered by your warranty. Read and follow the safety instructions that are shipped with your product.

Follow the safety guidelines listed in the safety instructions section.

Step

Align the expansion card holder with the projections on the chassis and push it down until firmly seated.

Next step

Follow the procedure listed in the After working inside your system section.

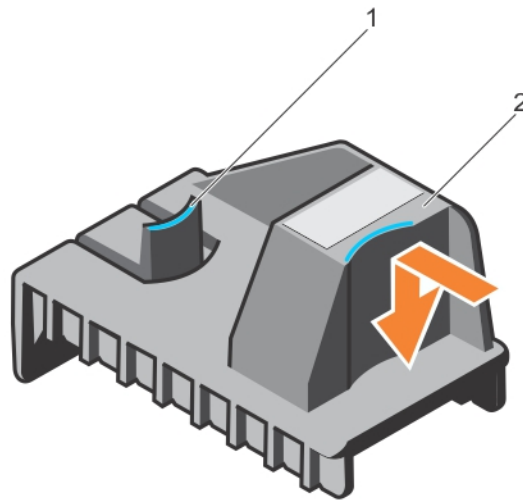

Figure 54. Installing the expansion card holder

1 tab

2 expansion card holder

Related links

- [Safety instructions](#)
- [After working inside your system](#)
- [Removing the expansion card holder](#)

Expansion cards

Expansion card installation guidelines

The following table describes the supported expansion cards:

Table 34. Supported PCI express generation 3 expansion cards

PCIe Slot	Processor Connection	Height	Length	Link Width	Slot Width
1 (Gen3)	Processor 1	Standard Height	Full Length	x16	x16
2 (Gen2)	Platform Controller Hub	Standard Height	Full Length*	x4	x8
3 (Gen3)	Processor 1	Standard Height	Full Length	x16	x16
4 (Gen3)	Processor 2	Standard Height	Half Length	x8	x8
5 (Gen2)	Processor 2	Standard Height	Full Length*	x4	x8
6 (Gen3)	Processor 2	Standard Height	Full Length	x16	x16
7 (Gen3)	Processor 2	Standard Height	Full Length	x16	x16
8 (Internal PERC Slot)	Processor 1	Standard Height	Half Length	x8	x8

*PCIe Generation 2 expansion card.

NOTE: To use PCIe slots 4, 5, 6, and 7, both the processors must be installed.

NOTE: The expansion-card slots are not hot-swappable.

The following table describes the installation order for installing expansion cards to ensure proper cooling and mechanical fit. The expansion cards with the highest priority must be installed first by using the slot priority indicated.

Table 35. Expansion card installation order

CPU	Card Priority	Card Type	Slot Priority	Maximum Allowed
CPU1	1	Dell PowerEdge Express Flash (PCIe SSD) Bridge	1, 3	1
	2	GPU (single width and double width)	3, 1	2
	3	RAID (H330)	8, 1, 3	1
		RAID (H730)	8	1
		RAID (H730P)	8, 1, 3	1
		RAID (H830)	3,1	2
	4	40 Gb NICs	3, 1	2
	5	FC16 HBA	3, 1	2
	6	10 Gb NICs	3, 1	2
		10 Gb NICs (Intel and Broadcom Dual Port 10GBASE-T)	1, 3	2
7	FC8 HBA	3, 1, 2	3	
9	1 Gb NICs	1, 3, 2	3	
CPU2		1 Gb NIC (Broadcom Quad Port)	1, 3	2
	10	Non-RAID	3, 1	2
	1	Dell PowerEdge Express Flash (PCIe SSD) Bridge	1, 3	1
	2	GPU (single width and double width)	3, 6, 7, 1	4
	3	RAID (H330)	8, 1, 3	1
		RAID (H730)	8	1
		RAID (H730P)	8, 1, 3	1
		RAID (H830)	3, 4, 6, 7, 1	2
	4	40 Gb NICs	3, 4, 6, 7, 1	5
	5	FC16 HBA	3, 4, 6, 7, 1	5
	FC16 HBA (QLE2660 V2 and QLE2662 V2)	3, 4, 6, 7, 1	2	
6	10 Gb NICs	3, 4, 6, 7, 1	5	
	10 Gb NIC (Emulex Dual Port)	3, 4, 6, 7, 1	2	

CPU	Card Priority	Card Type	Slot Priority	Maximum Allowed
		 NOTE: The slot priority for Emulex V2 Dual Port is 3, 4, 6, 7, 1 and the maximum number of cards supported is 5.		
		10 Gb NICs (Intel 10G BASE-T Dual Port and Broadcom 10G BASE-T Dual Port)	4, 6, 7, 1, 3	5
	7	FC8 HBA	3, 4, 6, 7, 1, 5, 2	7
	9	1 Gb NICs	3, 4, 6, 7, 1, 5, 2	7
		1 Gb NIC (Broadcom Quad Port)	4, 7, 1, 3, 6	5
	10	Non-RAID	3, 4, 6, 7, 1	5

Removing a expansion card

Prerequisites

- 1 Follow the safety guidelines listed in the safety instructions section.
- 2 Follow the procedure listed in the Before working inside your system section.
- 3 Remove the expansion card holder.

 **CAUTION: Many repairs may only be done by a certified service technician. You should only perform troubleshooting and simple repairs as authorized in your product documentation, or as directed by the online or telephone service and support team. Damage due to servicing that is not authorized by Dell is not covered by your warranty. Read and follow the safety instructions that are shipped with your product.**

Steps

- 1 If installed, disconnect the data cables from the PERC card and/or the power cables from the GPU card.
- 2 Press the expansion card latch and push down the latch to open it.
- 3 Hold the expansion card by its edge, and pull the card up to remove it from the expansion card connector and the system.
- 4 Install the filler brackets by performing the following steps:
 - a Align the slot on the filler bracket with the tab on the expansion card slot.
 - b Press the expansion card latch till the filler bracket locks into place.

 **NOTE: Filler brackets must be installed in empty expansion-card slots to maintain FCC certification of the system. The brackets also keep dust and dirt out of the system and aid in proper cooling and airflow inside the system.**

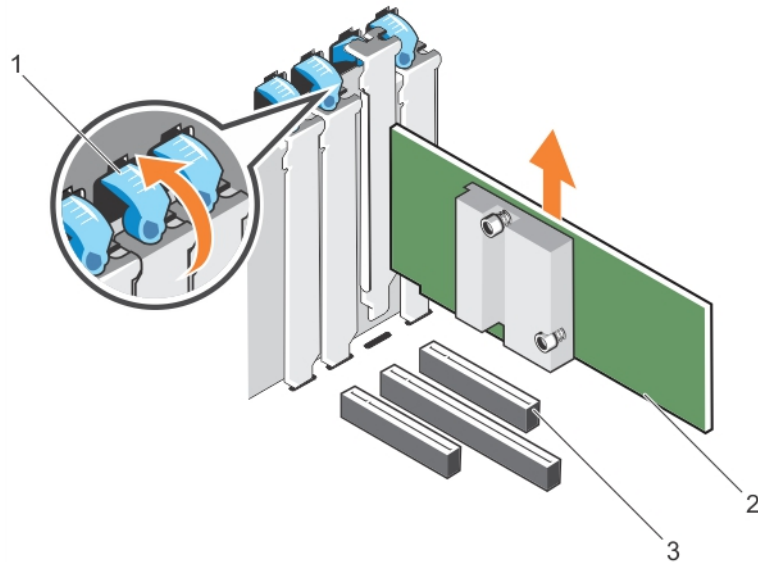

Figure 55. Removing an expansion card

- | | |
|--|--|
| <ol style="list-style-type: none"> 1 expansion card latch 3 expansion card connector | <ol style="list-style-type: none"> 2 expansion card |
|--|--|

Related links

- [Safety instructions](#)
- [Before working inside your system](#)
- [After working inside your system](#)
- [Installing an expansion card](#)

Installing an expansion card

Prerequisites

- 1 Follow the safety guidelines listed in the safety instructions section.
- 2 Follow the procedure listed in the Before working inside your system section.
- 3 Remove the expansion card holder.

⚠ CAUTION: Many repairs may only be done by a certified service technician. You should only perform troubleshooting and simple repairs as authorized in your product documentation, or as directed by the online or telephone service and support team. Damage due to servicing that is not authorized by Dell is not covered by your warranty. Read and follow the safety instructions that are shipped with your product.

Steps

- 1 Unpack the expansion card and prepare it for installation.
For instructions, see the documentation accompanying the card.
- 2 Open the expansion card latch adjacent to the slot you want to install the expansion card.
- 3 Remove the existing expansion card or filler bracket from the expansion card holder.

📘 NOTE: Store this bracket for future use. Filler brackets must be installed in empty expansion-card slots to maintain FCC certification of the system. The brackets also keep dust and dirt out of the system and aid in proper cooling and airflow inside the system.

- 4 Holding the card by its edges, position the card so that the card-edge connector aligns with the expansion card connector.

- 5 Insert the card-edge connector firmly into the expansion card connector until the card is fully seated.
- 6 Close the expansion card latch by pushing the latch up until the latch snaps into place.
- 7 Connect any cables to the expansion card.
- 8 Replace the expansion card holder.

Next steps

- 1 Install the expansion card holder.
- 2 Follow the procedure listed in the After working inside your system section.

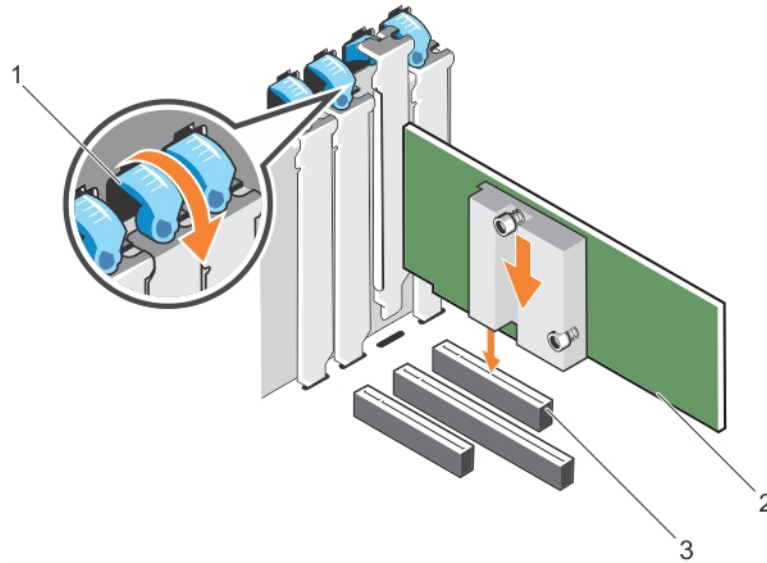

Figure 56. Installing an expansion card

- | | |
|--|--|
| <ol style="list-style-type: none"> 1 expansion card latch 3 expansion card connector | <ol style="list-style-type: none"> 2 expansion card |
|--|--|

Related links

- [Safety instructions](#)
- [Before working inside your system](#)

GPU card holder (optional)

Removing the optional GPU card holder

Prerequisites

- 1 Follow the safety guidelines listed in the safety instructions section.
- 2 Follow the procedure listed in the Before working inside your system section
- 3 Remove the cooling shroud.

⚠ CAUTION: Many repairs may only be done by a certified service technician. You should only perform troubleshooting and simple repairs as authorized in your product documentation, or as directed by the online or telephone service and support team. Damage due to servicing that is not authorized by Dell is not covered by your warranty. Read and follow the safety instructions that are shipped with your product.

Step

Press the release tab and pull the GPU card holder out of the chassis.

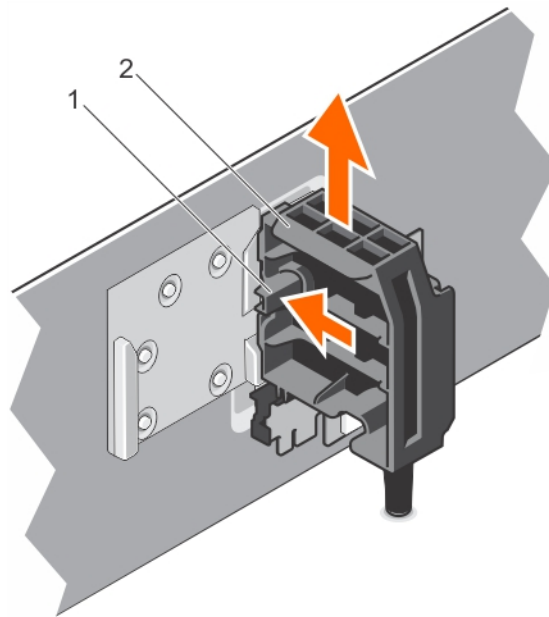

Figure 57. Removing the GPU card holder

1 release tab

2 GPU card holder

Next steps

- 1 Install the cooling shroud.
- 2 Follow the procedure listed in the After working inside your system section.

Related links

- [Safety instructions](#)
- [Installing the optional GPU card holder](#)
- [Before working inside your system](#)
- [Removing the cooling shroud](#)

Installing the optional GPU card holder

Prerequisites

- 1 Follow the safety guidelines listed in the safety instructions section.
- 2 Follow the procedure listed in the Before working inside your system section.

CAUTION: Many repairs may only be done by a certified service technician. You should only perform troubleshooting and simple repairs as authorized in your product documentation, or as directed by the online or telephone service and support team. Damage due to servicing that is not authorized by Dell is not covered by your warranty. Read and follow the safety instructions that are shipped with your product.

Step

Align the GPU card holder with the slots on the chassis and the guide pin, and push down the GPU card holder until it is firmly seated.

Next step

Follow the procedure listed in the After working inside your system section.

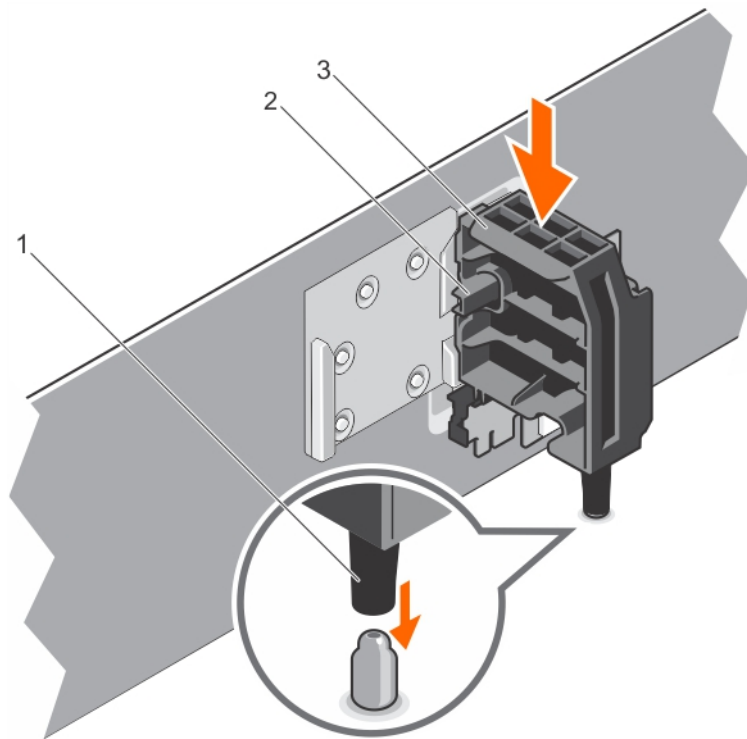

Figure 58. Installing the GPU card holder

- | | | | |
|---|-----------------|---|-------------|
| 1 | guide pin | 2 | release tab |
| 3 | GPU card holder | | |

Related links

- [Safety instructions](#)
- [After working inside your system](#)
- [Removing the optional GPU card holder](#)

GPU cards (optional)

GPU card installation guidelines

Observe the following guidelines while installing a GPU card:

- Ensure that the GPU enablement kit is ready.
- Ensure that all GPU cards are of the same type or model.
- Each GPU card supports up to 6 GB of dedicated GDDR5 memory.
- A single processor configuration only supports up to two double or single width cards on slots 1 and 3.
- A dual processor configuration supports up to four double or single width cards on slots 1, 3, 6, and 7.
- Both the processors must be installed to use slots 6 and 7.
- Two double-width GPU cards on a single processor configuration and four double width GPU cards on a dual processor configuration.
- For four GPGPU configuration, only one PERC can be supported on internal slot.
- Four double-width 300 W GPU cards (Intel 3120A or Intel 7120A) on a dual processor configuration or two double-width 300 W GPU cards (Intel 3120A or Intel 7120A) on a single processor configuration cannot operate at an ambient temperature above 30 °C.
- The 3.5 inch x18 hard-drive system configuration supports two double-width 300 W GPU cards (Intel 3120A or Intel 7120A) on slots 3 and 6 on dual processor configuration, and one double-width 300 W GPU card (Intel 3120A or Intel 7120A) on slot 3 on single processor configuration.

- A system with Express Flash configuration supports a maximum of two GPU cards.
- The GPU cards must be installed:
 - On the x16 PCIe Generation 3 interfaces available on slots 1, 3, 6, and 7.
 - On systems that support one 5.25-inch removable media storage devices.
 - On systems with six fan configuration.
 - On systems that have 1100 W and 1600 W power supply.

NOTE: When you have more than two GPU cards on your system, you will need two 1100 W PSUs installed on your system.

NOTE: For Nvidia Tesla m60A GPGPU support, add another adapter cable to fit the M60 Power pins.

Removing an optional GPU card

Prerequisites

- 1 Follow the safety guidelines listed in the safety instructions section.
- 2 Follow the procedure listed in the Before working inside your system section.
- 3 Remove the cooling shroud.
- 4 Remove the expansion card holder.

CAUTION: Many repairs may only be done by a certified service technician. You should only perform troubleshooting and simple repairs as authorized in your product documentation, or as directed by the online or telephone service and support team. Damage due to servicing that is not authorized by Dell is not covered by your warranty. Read and follow the safety instructions that are shipped with your product.

Steps

- 1 Disconnect the cables from the GPU card.

CAUTION: Do not use excessive force when removing the cables as it can damage the connectors.

- 2 Open the two expansion card latches by pressing the latch and then pushing the latch toward the rear.
- 3 Hold the card by its edge, and pull the card up to remove it from the card connector and the system.

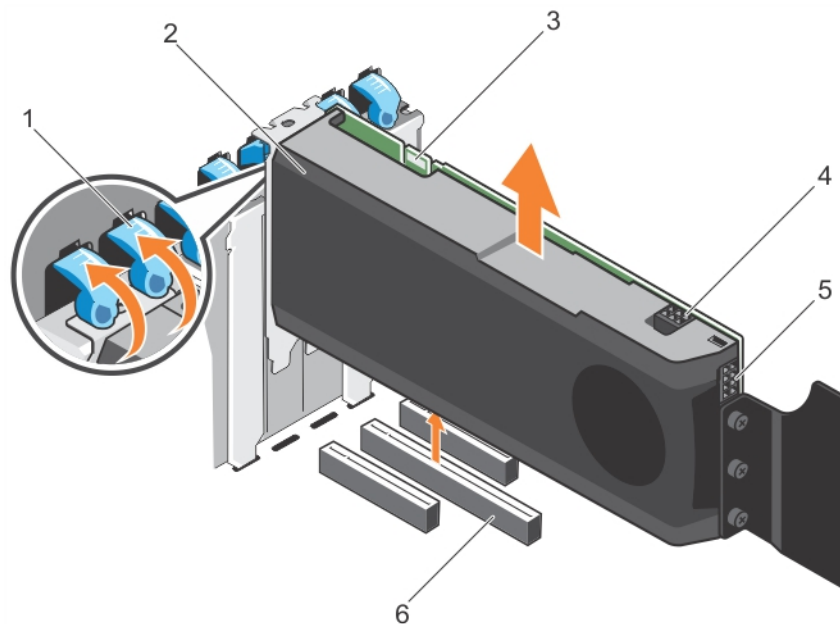

Figure 59. Removing a GPU card

- | | | | |
|---|--------------------------|---|--------------------------|
| 1 | expansion card latch (2) | 2 | GPU card |
| 3 | SLI data connector | 4 | GPU card power connector |
| 5 | GPU card power connector | 6 | x16 connector |

Next steps

- 1 Perform the following steps to install the filler brackets:
 - a Align the slot on the filler bracket with the tab on the expansion card slot.
 - b Press the expansion card latch till the filler bracket locks into place.

NOTE: Filler brackets must be installed in empty expansion-card slots to maintain FCC certification of the system. The brackets also keep dust and dirt out of the system and aid in proper cooling and airflow inside the system.

- 2 Close the two expansion card latches by pushing the latch until the latch snaps into place.
- 3 Replace the expansion card holder.
- 4 Install the cooling shroud.
- 5 Follow the procedure listed in the After working inside your system section.

Related links

- [Safety instructions](#)
- [After working inside your system](#)
- [Installing the cooling shroud](#)
- [Installing the expansion card holder](#)

Installing an optional GPU card

Prerequisites

CAUTION: Many repairs may only be done by a certified service technician. You should only perform troubleshooting and simple repairs as authorized in your product documentation, or as directed by the online or telephone service and support team. Damage due to servicing that is not authorized by Dell is not covered by your warranty. Read and follow the safety instructions that are shipped with your product.

- 1 Follow the safety guidelines listed in the Safety instructions section.
- 2 Follow the procedure listed in the Before working inside your system section.
- 3 Remove the cooling shroud.
- 4 Remove the expansion card holder.
- 5 Open the two expansion card latches.
- 6 Remove the filler brackets.

NOTE: Store this bracket for future use. Filler brackets must be installed in empty expansion-card slots to maintain FCC certification of the system. The brackets also keep dust and dirt out of the system and aid in proper cooling and airflow inside the system.

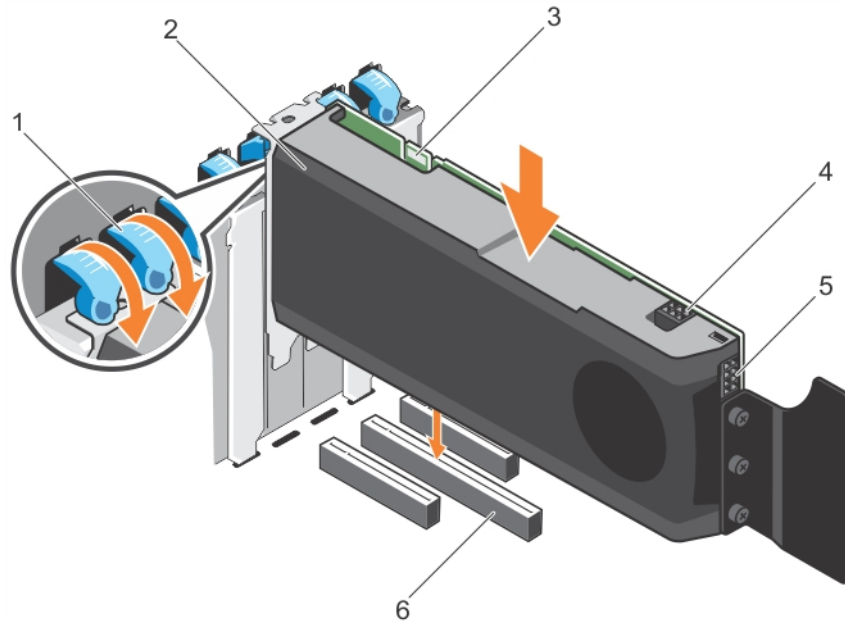

Figure 60. Installing a GPU card

- | | | | |
|---|--------------------------|---|--------------------------|
| 1 | expansion card latch (2) | 2 | GPU card |
| 3 | SLI data connector | 4 | GPU card power connector |
| 5 | GPU card power connector | 6 | x16 connector |

Steps

- 1 Locate the x16 slot on the system board.
- 2 Insert the GPU card into the slot.
- 3 Connect the cables from PIB to the GPU card.
- 4 Close the two expansion card latches.

Next steps

- 1 Install the expansion card holder.
- 2 Install the cooling shroud.
- 3 Follow the procedure listed in the After working inside your system section.

Related links

- [After working inside your system](#)
- [Installing the cooling shroud](#)
- [Installing the expansion card holder](#)
- [Safety instructions](#)
- [Before working inside your system](#)
- [Removing the cooling shroud](#)
- [Removing an optional GPU card](#)
- [Removing the expansion card holder](#)

Internal dual SD module (optional)

The Internal Dual SD Module (IDSDM) card provides two SD card slots. This card offers the following features:

- Dual card operation — maintains a mirrored configuration by using SD cards in both the slots and provides redundancy.
 - ① **NOTE:** When the Redundancy option is set to Mirror Mode in the Integrated Devices screen of System Setup, the information is replicated from one SD card to another.
- Single card operation — single card operation is supported, but without redundancy.

Removing the optional internal dual SD module

Prerequisites

⚠ CAUTION: Many repairs may only be done by a certified service technician. You should only perform troubleshooting and simple repairs as authorized in your product documentation, or as directed by the online or telephone service and support team. Damage due to servicing that is not authorized by Dell is not covered by your warranty. Read and follow the safety instructions that are shipped with your product.

- 1 Follow the safety guidelines listed in the Safety instructions section.
- 2 Follow the procedure listed in the Before working inside your system section.
- 3 If installed, remove the SD cards.

① **NOTE:** Temporarily label each SD card with its corresponding slot number before removal. Reinstall the SD cards into the corresponding slots.

Steps

- 1 Locate the internal dual SD module (IDSDM) on the system board. To locate the internal dual SD module connector, see the System board connectors section.
- 2 Holding the pull tab, lift the IDSDM out of the system.

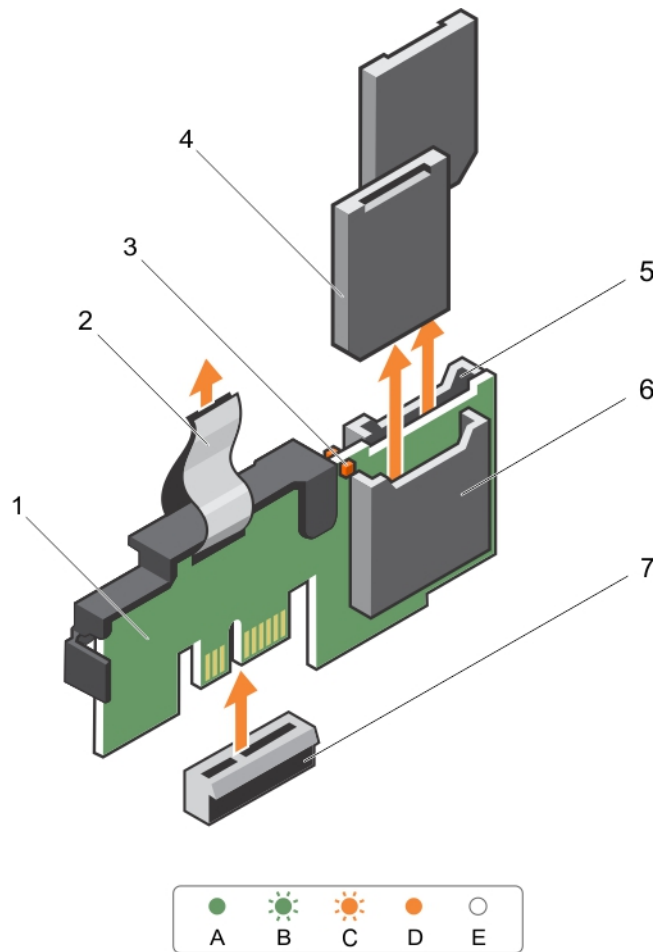

Figure 61. Removing the internal dual SD module (IDSDM)

- | | | | |
|---|--------------------------|---|----------------|
| 1 | IDSDM | 2 | pull tab |
| 3 | LED status indicator (2) | 4 | SD card (2) |
| 5 | SD card slot 2 | 6 | SD card slot 1 |
| 7 | IDSDM connector | | |

The following table describes the IDSDM indicator codes:

Table 36. IDSDM indicator codes

Convention	IDSDM indicator code	Description
A	Green	Indicates that the card is online.
B	Flashing green	Indicates rebuild or activity.
C	Flashing amber	Indicates card mismatch or that the card has failed.
D	Amber	Indicates that the card is offline, has failed, or is write protected.
E	Not lit	Indicates that the card is missing or is booting.

Next steps

- 1 Install the IDSDM.
- 2 Follow the procedure listed in the After working inside your system section.

Related links

- [Safety instructions](#)
- [Before working inside your system](#)
- [Installing the optional internal dual SD module](#)

Installing the optional internal dual SD module

Prerequisites

⚠ CAUTION: Many repairs may only be done by a certified service technician. You should only perform troubleshooting and simple repairs as authorized in your product documentation, or as directed by the online or telephone service and support team. Damage due to servicing that is not authorized by Dell is not covered by your warranty. Read and follow the safety instructions that are shipped with your product.

- 1 Follow the safety guidelines listed in the Safety instructions section.
- 2 Follow the procedure listed in the Before working inside your system section.

📌 NOTE: Temporarily label each SD card with its corresponding slot before removal.

Steps

- 1 Locate the internal dual SD module (IDSDM) connector on the system board. To locate the internal dual SD module connector, see the System board connectors section.
- 2 Align the IDSDM with the connector on the system board.
- 3 Push the IDSDM until it is firmly seated on the system board.

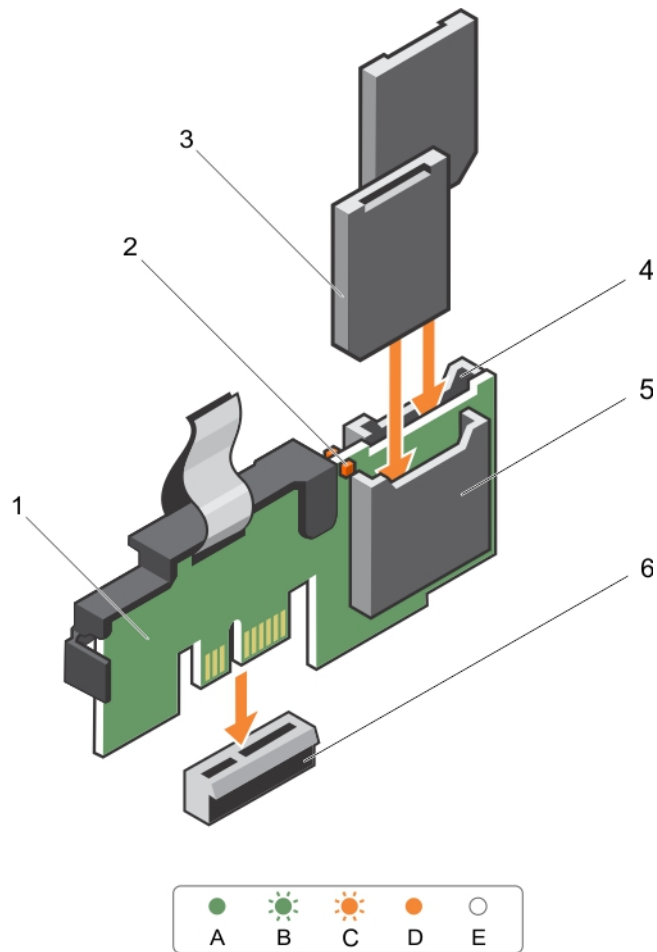

Figure 62. Installing the optional internal dual SD module

- | | | | |
|---|-------------------------|---|--------------------------|
| 1 | Internal Dual SD module | 2 | LED status indicator (2) |
| 3 | SD card (2) | 4 | SD card slot 2 |
| 5 | SD card slot 1 | 6 | IDSDM connector |

Next steps

- 1 Install the SD cards.

NOTE: Re-install the SD cards into the same slots based on the labels you had marked on the cards during removal.

- 2 Follow the procedure listed in the After working inside your system section.

Related links

- [Safety instructions](#)
- [Before working inside your system](#)
- [Safety instructions](#)
- [Before working inside your system](#)

Internal SD card

Removing an internal SD card

Prerequisites

- 1 Follow the safety guidelines listed in the Safety instructions section.
- 2 Follow the procedure listed in the Before working inside your system section.

⚠ CAUTION: Many repairs may only be done by a certified service technician. You should only perform troubleshooting and simple repairs as authorized in your product documentation, or as directed by the online or telephone service and support team. Damage due to servicing that is not authorized by Dell is not covered by your warranty. Read and follow the safety instructions that are shipped with your product.

ⓘ NOTE: When the Redundancy option is set to Mirror Mode in the Integrated Devices screen of System Setup, the information is replicated from one SD card to another.

ⓘ NOTE: Temporarily label each SD card with its corresponding slot number before removal. Re-install the SD card(s) into the corresponding slots.

Step

Locate the SD card slot on the internal dual SD module and press the card to release it from the slot.

Next step

Follow the procedure listed in the After working inside your system section.

Related links

- [Safety instructions](#)
- [Installing the optional internal dual SD module](#)
- [Before working inside your system](#)
- [After working inside your system](#)

Installing an internal SD card

Prerequisites

- 1 Follow the safety guidelines listed in the Safety instructions section.
- 2 Follow the procedure listed in the Before working inside your system section.
- 3 If installed, remove the cooling shroud.

⚠ CAUTION: Many repairs may only be done by a certified service technician. You should only perform troubleshooting and simple repairs as authorized in your product documentation, or as directed by the online or telephone service and support team. Damage due to servicing that is not authorized by Dell is not covered by your warranty. Read and follow the safety instructions that are shipped with your product.

ⓘ NOTE: To use an SD card with your system, ensure that the Internal SD Card Port is enabled in System Setup.

ⓘ NOTE: Temporarily label each SD card with its corresponding slot number before removal. Re-install the SD card(s) into the corresponding slots.

Steps

- 1 Locate the SD card connector on the internal dual SD module. Orient the SD card appropriately and insert the contact-pin end of the card into the slot.

ⓘ NOTE: The slot is keyed to ensure correct insertion of the card.

- 2 Press the card into the card slot to lock it into place.

Next steps

- 1 If removed, replace the cooling shroud.
- 2 Follow the procedure listed in the After working inside your system section.

Processors and heat sinks

Use the following procedure when:

- Removing and installing a heat sink
- Installing an additional processor
- Replacing a processor

 **NOTE:** To ensure proper system cooling, you must install a processor blank in any empty processor socket.

Removing a heat sink

Prerequisites

 **CAUTION:** Never remove the heat sink from a processor unless you intend to remove the processor. The heat sink is necessary to maintain proper thermal conditions.

 **WARNING:** The heat sink will be hot to touch. Allow the heat sink to cool for some time after powering down the system.

- 1 Follow the safety guidelines listed in the Safety instructions section.
- 2 Keep the Phillips #2 screwdriver ready.
- 3 Follow the procedure listed in the Before working inside your system section.
- 4 If installed, remove the cooling fan assembly.
- 5 If installed, remove the full-length PCIe card(s).
- 6 Remove the cooling shroud.

Steps

- 1 Loosen one of the screws that secure the heat sink to the system board.
Allow some time (approximately 30 seconds) for the heat sink to loosen from the processor.
- 2 Remove the screw diagonally opposite the screw you first removed.
- 3 Repeat the procedure for the remaining two screws.
- 4 Remove the heat sink.

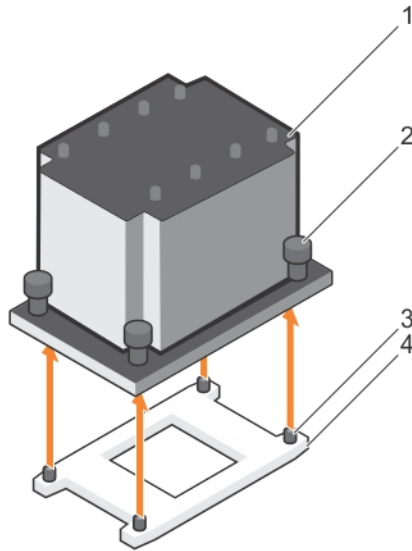

Figure 63. Removing a heat sink

- | | | | |
|---|---------------------------|---|----------------------|
| 1 | heat sink | 2 | retention screws (4) |
| 3 | retention screw slots (4) | 4 | processor socket |

Next steps

- 1 Replace the heat sink(s) and processor(s).
- 2 Follow the procedure listed in the After working inside your system section.

Related links

- [Safety instructions](#)
- [Before working inside your system](#)
- [Installing a heat sink](#)

Removing a processor

Prerequisites

⚠ CAUTION: Many repairs may only be done by a certified service technician. You should only perform troubleshooting and simple repairs as authorized in your product documentation, or as directed by the online or telephone service and support team. Damage due to servicing that is not authorized by Dell is not covered by your warranty. Read and follow the safety instructions that are shipped with your product.

ⓘ NOTE: This is a Field Replaceable Unit (FRU). Removal and installation procedures should be performed only by Dell certified service technicians.

ⓘ NOTE: To ensure proper system cooling, you must install a processor blank in any empty processor socket.



- 1 Follow the safety guidelines listed in the Safety instructions section.
- 2 Follow the procedure listed in the Before working inside your system section.
- 3 Keep the Phillips #2 screwdriver ready.
- 4 If installed, remove the full-length PCIe card(s).
- 5 Remove the cooling shroud.
- 6 Remove the heat sink.
- 7 If you are upgrading your system, download the latest system BIOS version from Dell.com/support and follow the instructions included in the compressed download file to install the update on your system.

 **NOTE:** You can update the system BIOS by using the Dell Lifecycle Controller.

 **CAUTION:** The processor is held in its socket under strong pressure. Be aware that the release lever can spring up suddenly if not firmly grasped.

 **WARNING:** The processor is hot to touch for some time after the system has been powered down. Allow the processor to cool before removing it.

Steps

- 1 Release the *open first* socket lever near the unlock icon  by pushing the lever down and out from under the tab.
- 2 Release the *close first* socket release lever near the lock icon  by pushing the lever down and out from under the tab. Lift the lever 90 degrees upward.
- 3 Lower the *open first* socket-release lever to lift the processor shield.
- 4 Hold the tab on the processor shield and lift the processor shield until the *open first* socket-release lever lifts up.

 **CAUTION:** The socket pins are fragile and can be permanently damaged. Be careful not to bend the pins in the socket when removing the processor out of the socket.

- 5 Lift the processor out of the socket and leave the *open first* socket-release lever up.

 **NOTE:** If you are permanently removing the processor, you must install a socket protective cap in the vacant socket to protect the socket pins and keep the socket free of dust.

 **NOTE:** After removing the processor, place it in an anti-static container for reuse, return, or temporary storage. Do not touch the bottom of the processor. Touch only the side edges of the processor.

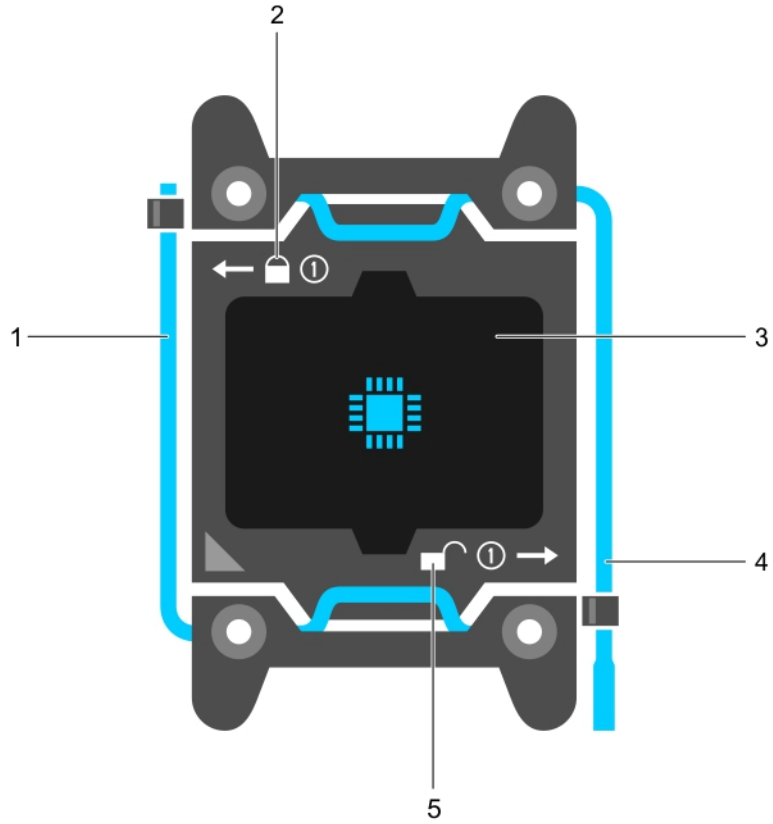

Figure 64. Processor shield

- | | | | |
|---|---|---|--|
| 1 | <i>close first</i> socket release lever | 2 | lock icon |
| 3 | processor | 4 | <i>open first</i> socket release lever |
| 5 | unlock icon | | |

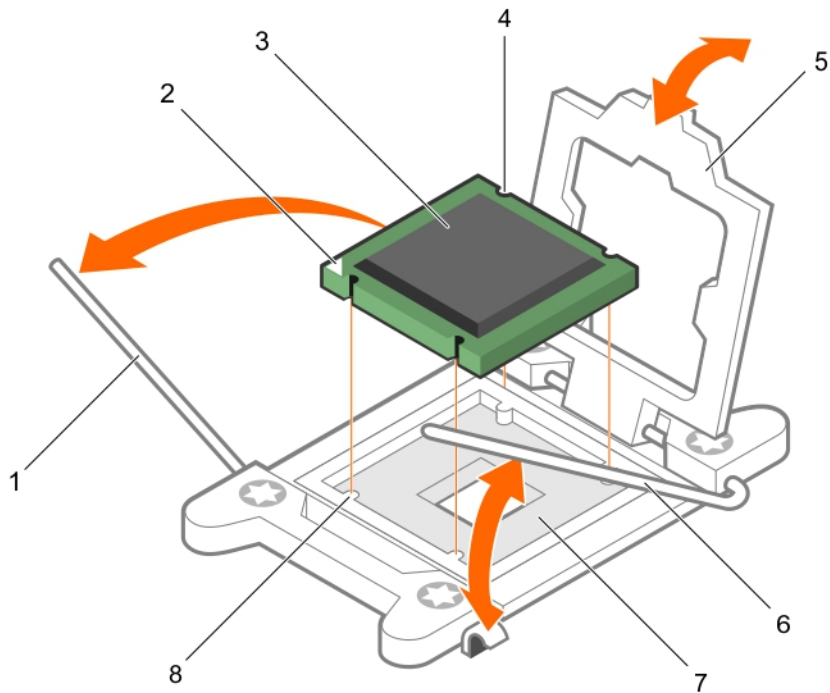

Figure 65. Removing and installing a processor

- | | | | |
|---|----------------------------------|---|---------------------------------|
| 1 | close first socket-release lever | 2 | pin-1 indicator of processor |
| 3 | processor | 4 | slot (4) |
| 5 | processor shield | 6 | open first socket-release lever |
| 7 | socket | 8 | socket keys (4) |

Next steps

- 1 Replace the processor(s).
- 2 Install the heat sink.
- 3 Reinstall the cooling shroud.
- 4 Follow the procedure listed in the After working inside your system section.

Related links

- [Safety instructions](#)
- [Before working inside your system](#)
- [Installing a processor](#)

Installing a processor

Prerequisites

- ⚠ CAUTION:** Many repairs may only be done by a certified service technician. You should only perform troubleshooting and simple repairs as authorized in your product documentation, or as directed by the online or telephone service and support team. Damage due to servicing that is not authorized by Dell is not covered by your warranty. Read and follow the safety instructions that are shipped with your product.

- 1 Follow the safety guidelines listed in the Safety instructions section.
- 2 Follow the procedure listed in the Before working inside your system section.
- 3 Keep the Phillips #2 screwdriver ready.
- 4 If you are upgrading your system, download the latest system BIOS version from **Dell.com/support** and follow the instructions included in the compressed download file to install the update on your system.

 **NOTE:** You can also update the system BIOS by using the Dell Lifecycle Controller.

- 5 If installed, remove the cooling fan assembly.
- 6 If installed, remove the full-length PCIe card.
- 7 Remove the cooling shroud.

 **NOTE:** If applicable, close the expansion card latch on the cooling shroud to release the full length card.

- 8 If connected, disconnect the cables from expansion card (s).
- 9 If installed, remove the expansion card riser.

 **WARNING:** The heat sink and processor are too hot to touch for some time after the system has been powered down. Allow the heat sink and processor to cool down before handling them.



 **CAUTION:** Never remove the heat sink from a processor unless you intend to remove the processor. The heat sink is necessary to maintain proper thermal conditions.

 **NOTE:** If you are installing a single processor, it must be installed in socket CPU1.

Steps

- 1 Unpack the new processor.

 **NOTE:** If the processor has previously been used in a system, remove any remaining thermal grease from the processor by using a lint-free cloth.

- 2 Locate the processor socket.
- 3 If applicable, remove the socket protective cap.
- 4 Release the *open first* socket-release lever near the unlock icon  by pushing the lever down and out from under the tab.
- 5 Similarly, release the *close first* socket-release lever near the lock icon  by pushing the lever down and out from under the tab. Lift the lever 90 degrees upward.
- 6 Hold the tab near the lock symbol on the processor shield and lift it up and out of the way.

 **CAUTION:** Positioning the processor incorrectly can permanently damage the system board or the processor. Be careful not to bend the pins in the socket.

 **CAUTION:** While removing or reinstalling the processor, wipe your hands of any contaminants. Contaminants on the processor pins such as thermal grease or oil can damage the processor.

- 7 Align the processor with the socket keys.

 **CAUTION:** Do not use force to seat the processor. When the processor is positioned correctly, it engages easily into the socket.

- 8 Align the pin-1 indicator of the processor with the triangle on the system board. .

 **CAUTION:** Do not use force to seat the processor. When the processor is positioned correctly, it engages easily into the socket.

- 9 Place the processor on the socket such that the slots on the processor align with the socket keys.
- 10 Close the processor shield.

- 11 Lower the *close first* socket-release lever near the lock icon  and push it under the tab to lock it.

- 12 Similarly, lower the *open first* socket-release lever near the unlock icon  and push it under the tab to lock it.

Next steps

NOTE: Ensure that you install the heat sink after you install the processor. The heat sink is necessary to maintain proper thermal conditions.

- 1 Install the heat sink.
- 2 If removed, reinstall the PCIe expansion card riser.
- 3 If disconnected, reconnect the cables to the expansion card(s).
- 4 While booting, press F2 to enter System Setup and verify that the processor information matches the new system configuration.
- 5 Run the system diagnostics to verify that the new processor operates correctly.

Related links

- [Safety instructions](#)
- [Removing the cooling shroud](#)
- [Removing the control panel assembly](#)
- [Removing a processor](#)
- [After working inside your system](#)

Installing a heat sink

Prerequisites

CAUTION: Many repairs may only be done by a certified service technician. You should only perform troubleshooting and simple repairs as authorized in your product documentation, or as directed by the online or telephone service and support team. Damage due to servicing that is not authorized by Dell is not covered by your warranty. Read and follow the safety instructions that are shipped with your product.

- 1 Follow the safety guidelines listed in the Safety instructions section.
- 2 Keep the Phillips #2 screwdriver ready.
- 3 Follow the procedure listed in the Before working inside your system section.
- 4 If installed, remove the cooling fan assembly.
- 5 If installed, remove the full-length PCIe card.
- 6 Install the processor.

Steps

- 1 If you are using an existing heat sink, remove the thermal grease from the heat sink by using a clean lint-free cloth.
- 2 Use the thermal grease syringe included with your processor kit to apply the grease in a thin spiral on the top of the processor.

CAUTION: Applying too much thermal grease can result in excess grease coming in contact with and contaminating the processor socket.

NOTE: The thermal grease syringe is intended for one-time use only. Dispose of the syringe after you use it.

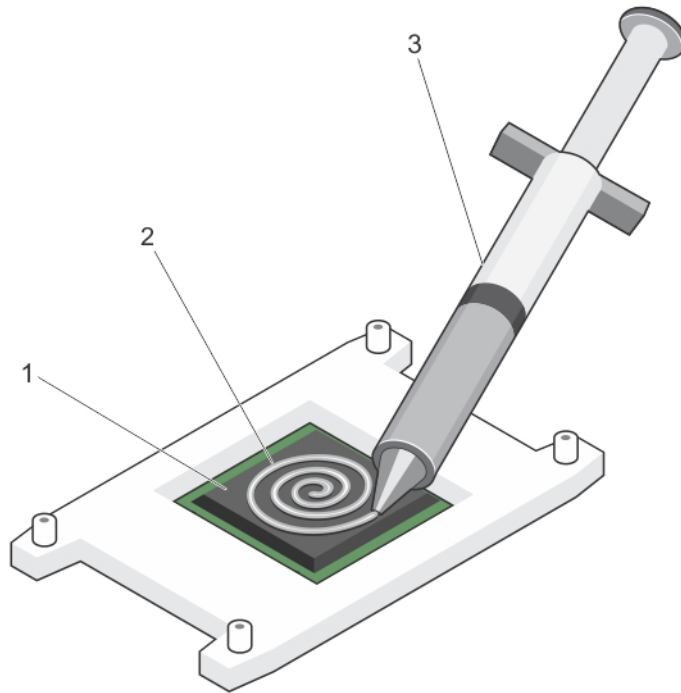

Figure 66. Applying thermal grease on the top of the processor

- 1 processor
- 2 thermal grease
- 3 thermal grease syringe

- 3 Place the heat sink onto the processor.
- 4 Tighten one of the four screws to secure the heat sink to the system board.
- 5 Tighten the screw diagonally opposite to the first screw you have tightened.

ⓘ NOTE: Do not over-tighten the heat sink retention screws when installing the heat sink. To prevent over-tightening, tighten the retention screw until resistance is felt, and stop after the screw is seated. The screw tension should not be more than 6 in-lb (6.9 kg-cm).

- 6 Repeat the procedure for the remaining two screws.

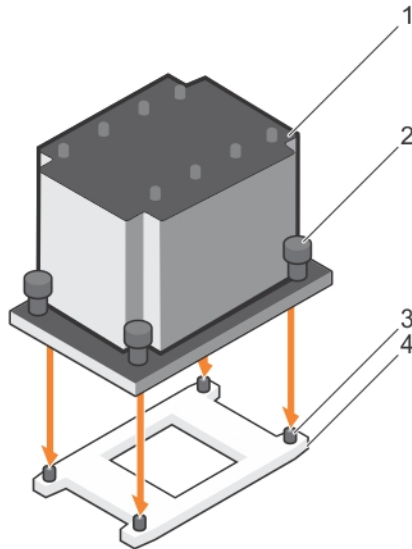

Figure 67. Installing the heat sink

- | | | | |
|---|--------------------------|---|---------------------|
| 1 | heat sink | 2 | retention screw (4) |
| 3 | retention screw slot (4) | 4 | processor socket |

Next steps

- 1 If applicable, install the PCIe card.
- 2 If applicable, install the cooling fan assembly.
- 3 Follow the procedure listed in the After working inside your system section.
- 4 While booting, press F2 to enter System Setup and verify that the processor information matches the new system configuration.
- 5 Run the system diagnostics to verify that the new processor operates correctly.

Related links

- [Safety instructions](#)
- [Before working inside your system](#)
- [Removing the optional cooling fan assembly](#)
- [Installing a processor](#)

Power supply unit

Your system supports either:

- Two 495 W, 750 W, 1100 W, or 1600 W (Platinum) AC power supply modules or
- Two 750 W (Titanium) AC power supply modules or
- Two 1100 W DC power supply modules

⚠ CAUTION: If two power supplies units (PSU) are used, they must be of the same maximum output power.

ℹ NOTE: 495 W, 750 W, and 1100 W Platinum power supplies are nominally rated for 100 VAC to 240 VAC input.

750 W Titanium and 1600 W Platinum power supplies are nominally rated for 200 VAC to 240 VAC input.

1100 W DC power supply is nominally rated for -(48-60) VDC input.

- ① **NOTE:** When two identical PSUs are installed, power supply redundancy (1+1 – with redundancy or 2+0 – without redundancy) is configured in system BIOS. In redundant mode, power is supplied to the system equally from both PSUs when Hot Spare is disabled. When Hot Spare is enabled, one of the PSUs will be put into standby when system utilization is low in order to maximize efficiency.
- ① **NOTE:** For AC power supplies, use only power supplies with the Extended Power Performance (EPP) label on the back. Mixing PSUs from previous generations of servers can result in a power supply mismatch condition or failure to turn on.
- ① **NOTE:** When you have more than two GPU cards on your system, you will need two 1100 W PSUs installed on your system.

Hot spare feature

Your system supports the hot spare feature that significantly reduces the power overhead associated with power supply redundancy.

When the hot spare feature is enabled, one of the redundant PSUs is switched to the sleep state. The active PSU supports 100 percent of the load, thus operating at higher efficiency. The PSU in the sleep state monitors output voltage of the active PSU. If the output voltage of the active PSU drops, the PSU in the sleep state returns to an active output state.

If having both PSUs active is more efficient than having one PSU in the sleep state, the active PSU can also activate the sleeping PSU.

The default PSU settings are as follows:

- If the load on the active PSU is more than 50 percent, then the redundant PSU is switched to the active state.
- If the load on the active PSU falls below 20 percent, then the redundant PSU is switched to the sleep state.

You can configure the hot spare feature by using the iDRAC settings. For more information about iDRAC settings, see the *Integrated Dell Remote Access Controller User's Guide* available at Dell.com/idracmanuals.

Removing an AC power supply unit

Prerequisites

- ⚠ **CAUTION:** Many repairs may only be done by a certified service technician. You should only perform troubleshooting and simple repairs as authorized in your product documentation, or as directed by the online or telephone service and support team. Damage due to servicing that is not authorized by Dell is not covered by your warranty. Read and follow the safety instructions that are shipped with your product.
- ⚠ **CAUTION:** The system needs one power supply for normal operation. On power-redundant systems, remove and replace only one power supply at a time in a system that is powered on.
- ① **NOTE:** You may have to unlatch and lift the optional cable management arm if it interferes with the power supply unit (PSU) removal. For information about the cable management arm, see the system's rack documentation.

Steps

- 1 Disconnect the power cable from the power source and from the PSU you intend to remove, and then remove the cables from the strap.
- 2 Press the release latch and slide the PSU out of the chassis by using the PSU handle.

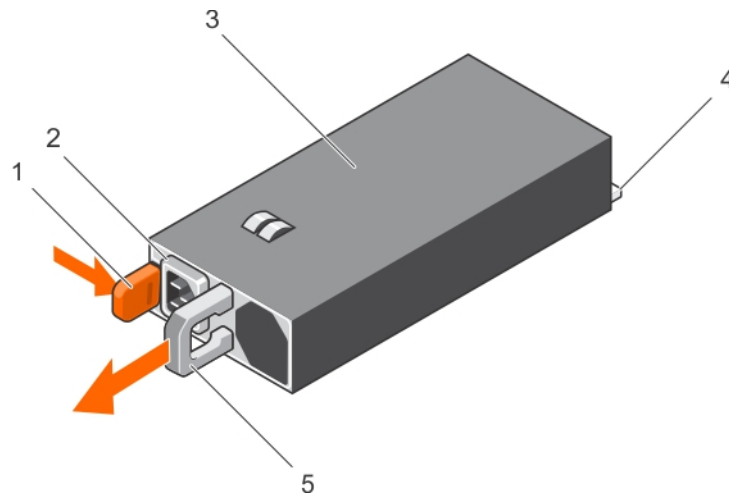

Figure 68. Removing an AC PSU

- | | | | |
|---|---------------|---|---------------------|
| 1 | release latch | 2 | PSU cable connector |
| 3 | PSU | 4 | power connector |
| 5 | PSU handle | | |

Related link

[Installing an AC power supply unit](#)

Installing an AC power supply unit

Prerequisites

⚠ CAUTION: Many repairs may only be done by a certified service technician. You should only perform troubleshooting and simple repairs as authorized in your product documentation, or as directed by the online or telephone service and support team. Damage due to servicing that is not authorized by Dell is not covered by your warranty. Read and follow the safety instructions that are shipped with your product.

📄 NOTE: The maximum output power (shown in watts) is listed on the PSU label.

- 1 Follow the safety guidelines listed in the Safety instructions section.
- 2 For systems that support redundant power supply units (PSUs), ensure that both the PSUs are of the same type and have the same maximum output power
- 3 If installed, remove the PSU blank.

Steps

- 1 Slide the new PSU into the chassis until the PSU is fully seated and the release latch snaps into place.

📄 NOTE: If you unlatched the cable management arm, relatch it. For information about the cable management arm, see the rack documentation of your system.

- 2 Connect the power cable to the PSU and plug the cable into a power outlet.

⚠ CAUTION: When connecting the power cable, secure the cable with the strap.

📄 NOTE: When installing, hot swapping, or hot-adding a new PSU, wait for 15 seconds for the system to recognize the PSU and determine its status. The power supply redundancy may not occur until discovery is complete. Wait until the new PSU is discovered and enabled before you remove the other PSU. The PSU status indicator turns green to signify that the PSU is functioning properly.

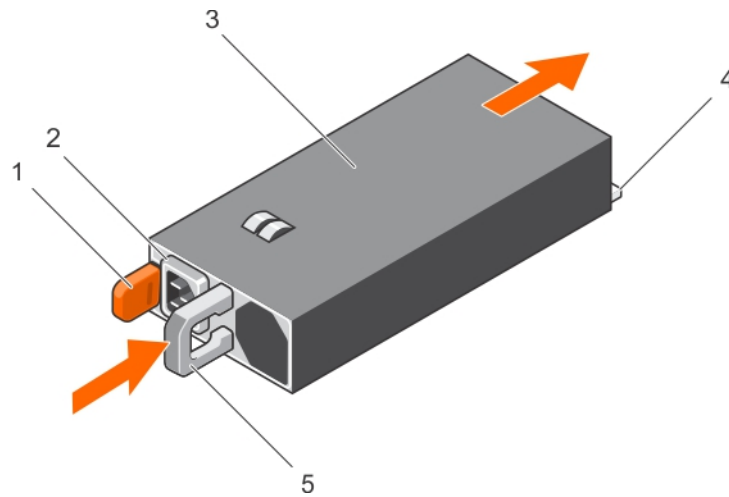

Figure 69. Installing an AC PSU

- | | | | |
|---|---------------|---|---------------------|
| 1 | release latch | 2 | PSU cable connector |
| 3 | PSU | 4 | power connector |
| 5 | PSU handle | | |

Related link

[Removing an AC power supply unit](#)

Wiring instructions for a DC power supply unit

Your system supports up to two $-(48-60)$ V DC power supply units (when available).

⚠ WARNING: For equipment using $-(48-60)$ V DC power supply units (PSUs), a qualified electrician must perform all connections to DC power and to safety grounds. Do not attempt connecting to DC power or installing grounds yourself. All electrical wiring must comply with applicable local or national codes and practices. Damage due to servicing that is not authorized by Dell is not covered by your warranty. Read and follow all safety instructions that came with the product.

⚠ CAUTION: Wire the unit with copper only, unless otherwise specified, use only 10 American Wire Gauge (AWG) wire rated minimum 90°C for source and return. Protect the $-(48-60)$ V DC (1 wire) with a branch circuit over-current protection rated 50 A for DC with a high interrupt current rating.

⚠ CAUTION: Connect the equipment to a $-(48-60)$ V DC supply source that is electrically isolated from the AC source (reliably grounded $-(48-60)$ V DC SELV source). Ensure that the $-(48-60)$ V DC source is efficiently secured to earth (ground).

📌 NOTE: A readily accessible disconnect device that is approved and rated, is incorporated in the field wiring.

Input requirements

- Supply voltage: $-(48-60)$ V DC
- Current consumption: 32 A (maximum)

Kit contents

- Dell part number 6RYJ9 terminal block or equivalent (1)
- #6-32 nut equipped with lock washer (1)

Required tools

Wire-stripper pliers, capable of removing insulation from size 10 AWG solid or stranded, insulated copper wire.

NOTE: Use alpha wire part number 3080 or equivalent (65/30 stranding).

Required wires

- One UL 10 AWG, 2 m maximum (stranded) black wire [–(48–60) V DC]
- One UL 10 AWG, 2 m maximum (stranded) red wire (V DC return)
- One UL 10 AWG, 2 m maximum green/yellow, green with a yellow stripe, stranded wire (safety ground)

Assembling and connecting the safety ground wire

Prerequisite

WARNING: For equipment using –(48–60) V DC power supply units (PSUs), a qualified electrician must perform all connections to DC power and to safety grounds. Do not attempt connecting to DC power or installing grounds yourself. All electrical wiring must comply with applicable local or national codes and practices. Damage due to servicing that is not authorized by Dell is not covered by your warranty. Read and follow all safety instructions that came with the product.

Steps

- 1 Strip the insulation from the end of the green or yellow wire, exposing approximately 4.5 mm (0.175 inch) of copper wire.
- 2 Using a hand-crimping tool (Tyco Electronics, 58433-3 or equivalent), crimp the ring-tongue terminal (Jeason Terminals Inc., R5-4SA or equivalent) to the green/yellow wire (safety ground wire).
- 3 Connect the safety ground wire to the grounding post on the back of the system by using a #6-32 nut equipped with a locking washer.

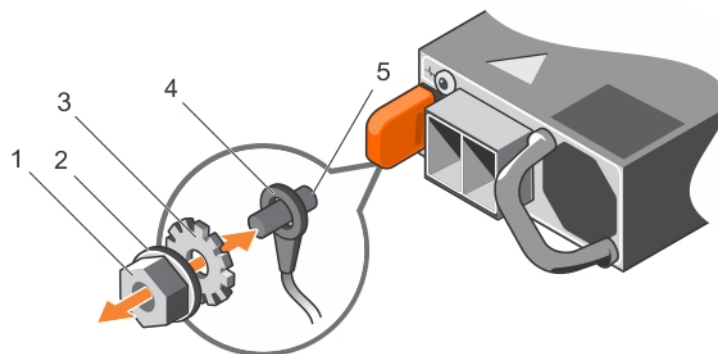

Figure 70. Assembling and connecting the safety ground wire

- | | | | |
|---|----------------|---|--------------------|
| 1 | #6-32 nut | 2 | spring washer |
| 3 | locking washer | 4 | safety ground wire |

Related link[Safety instructions](#)

Assembling the DC input power wires

Prerequisite

⚠ WARNING: For equipment using $-(48-60)$ V DC power supply units (PSUs), a qualified electrician must perform all connections to DC power and to safety grounds. Do not attempt connecting to DC power or installing grounds yourself. All electrical wiring must comply with applicable local or national codes and practices. Damage due to servicing that is not authorized by Dell is not covered by your warranty. Read and follow all safety instructions that came with the product.

Steps

- Strip the insulation from the ends of the DC power wires, exposing approximately 13 mm (0.5 inch) of copper wire.
 - ⚠ WARNING:** Reversing polarity when connecting DC power wires can permanently damage the power supply or the system.
- Insert the copper ends into the mating connectors and tighten the captive screws at the top of the mating connector using a Phillips #2 screwdriver.
 - ⚠ WARNING:** To protect the power supply from electrostatic discharge, the captive screws must be covered with the rubber cap before inserting the mating connector into the power supply.
- Rotate the rubber cap clockwise to fix it over the captive screws.
- Insert the mating connector into the power supply.

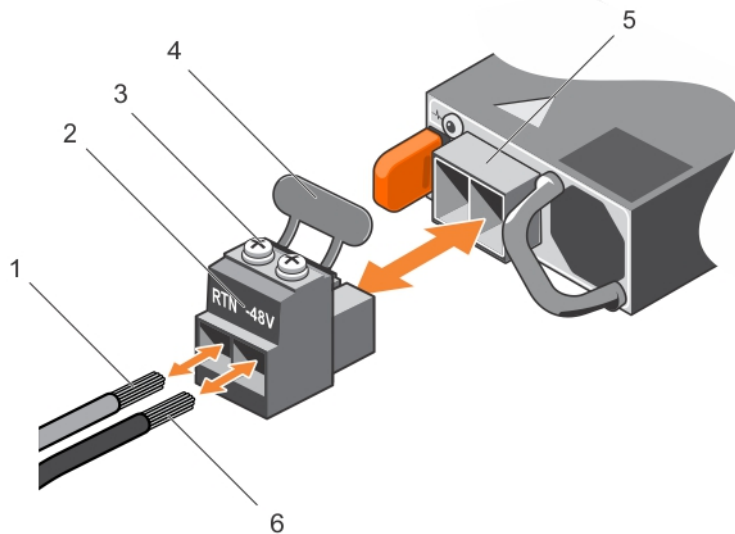
**Figure 71. Assembling the DC input power wires**

- | | | | |
|---|--------------------|---|--------------------|
| 1 | wire RTN | 2 | DC power connector |
| 3 | captive screws (2) | 4 | rubber cap |
| 5 | DC power socket | 6 | wire -48 V |

Related link[Safety instructions](#)

Removing a DC power supply unit

Prerequisites

- ⚠ WARNING:** For equipment using –(48–60) V DC power supply units (PSUs), a qualified electrician must perform all connections to DC power and to safety grounds. Do not attempt connecting to DC power or installing grounds yourself. All electrical wiring must comply with applicable local or national codes and practices. Damage due to servicing that is not authorized by Dell is not covered by your warranty. Read and follow all safety instructions that came with the product.
- ⚠ CAUTION:** The system needs one power supply for normal operation. On power-redundant systems, remove and replace only one power supply at a time in a system that is powered on.
- ℹ NOTE:** You may have to unlatch and lift the optional cable management arm if it interferes with power supply removal. For information about the cable management arm, see the rack documentation of your system.

Steps

- 1 Disconnect the power wires from the power source and the connector from the PSU you intend to remove.
- 2 Disconnect the safety ground wire.
- 3 Press the release latch and slide the PSU out of the chassis by using the PSU handle.

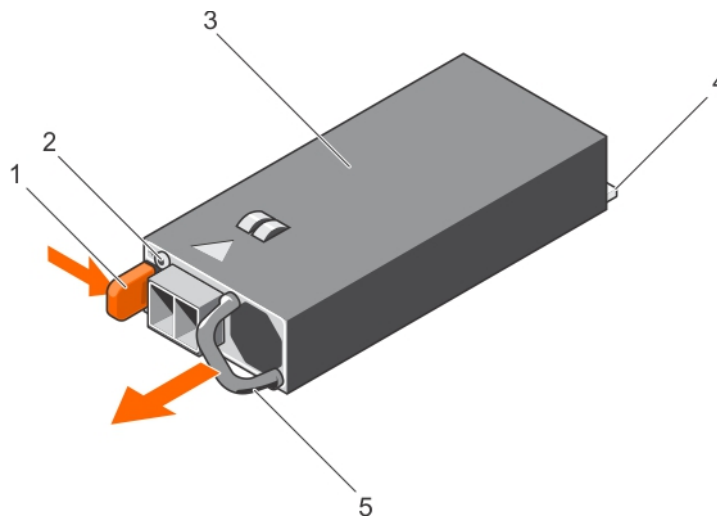

Figure 72. Removing a DC PSU

- | | | | |
|---|---------------|---|-------------------------------|
| 1 | release latch | 2 | power supply status indicator |
| 3 | PSU | 4 | power connector |
| 5 | PSU handle | | |

Related links

- [Safety instructions](#)
- [Installing a DC power supply unit](#)

Installing a DC power supply unit

Prerequisites

- ⚠ WARNING:** For equipment using –(48–60) V DC power supply units (PSUs), a qualified electrician must perform all connections to DC power and to safety grounds. Do not attempt connecting to DC power or installing grounds yourself. All electrical wiring must comply with applicable local or national codes and practices. Damage due to servicing that is not authorized by Dell is not covered by your warranty. Read and follow all safety instructions that came with the product.

- 1 Follow the safety guidelines listed in the Safety instructions section.
- 2 Follow the procedure listed in the Before working inside your system section.
- 3 If installed, remove the PSU blank.
- 4 Verify that both the PSUs are of the same type and have the same maximum output power.

NOTE: The maximum output power (shown in watts) is listed on the PSU label.

Steps

- 1 Slide the PSU into the chassis until the PSU is fully seated and the release latch snaps into place.

NOTE: If you have unlatched the cable management arm, relatch it. For information about the cable management arm, see the system's rack documentation.

- 2 Connect the safety ground wire.
- 3 Install the DC power connector in the PSU.

CAUTION: When connecting the power wires, ensure that you secure the wires with the strap to the PSU handle.

- 4 Connect the wires to a DC power source.

NOTE: When installing, hot-swapping, or hot-adding a new PSU, wait for 15 seconds for the system to recognize the PSU and determine its status. The PSU status indicator turns green to signify that the PSU is functioning properly.

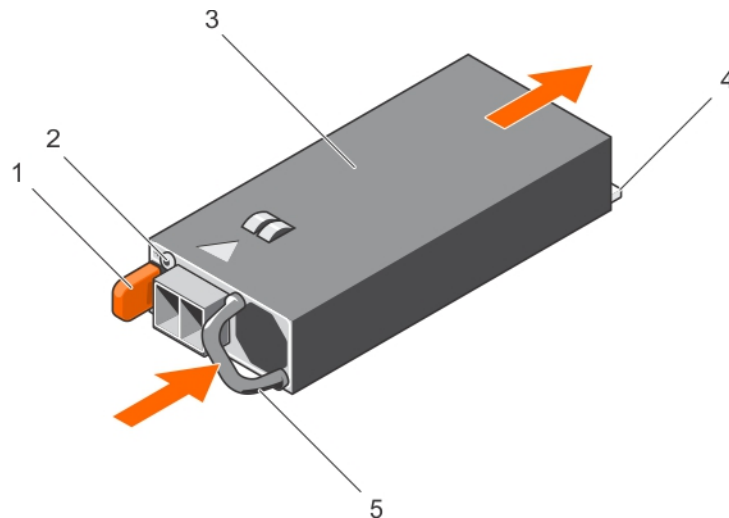

Figure 73. Installing a DC PSU

- | | | | |
|---|---------------|---|-------------------------------|
| 1 | release latch | 2 | power supply status indicator |
| 3 | PSU | 4 | power connector |
| 5 | PSU handle | | |

Next step

- Follow the procedure listed in the After working inside your system section.

Related links

- [Safety instructions](#)
- [Before working inside your system](#)
- [After working inside your system](#)
- [Removing a DC power supply unit](#)

Removing the power supply unit blank

If you are installing a second power supply unit (PSU), remove the PSU blank in the bay by pulling the blank outward.

CAUTION: To ensure proper system cooling, the power supply blank must be installed in the second PSU bay in a non-redundant configuration. Remove the PSU blank only if you are installing a second PSU.

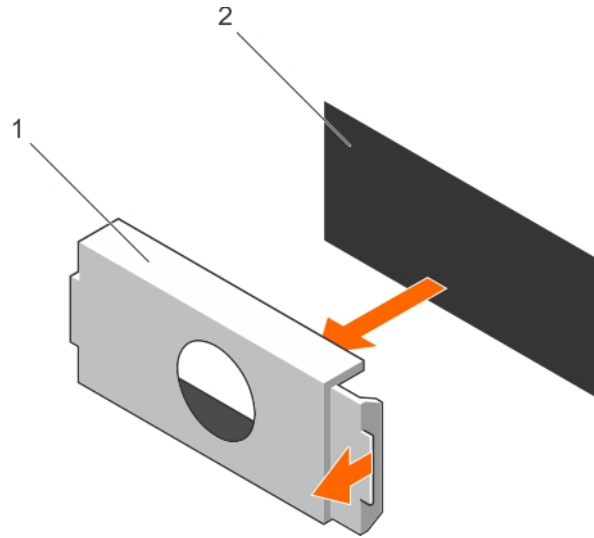

Figure 74. Removing the PSU blank

1 PSU blank

2 PSU bay

Related links

[Safety instructions](#)

[Installing the power supply unit blank](#)

Installing the power supply unit blank

Install the power supply unit (PSU) blank only in the second PSU bay.

Align the PSU blank with the PSU bay and push it into the chassis until it clicks into place.

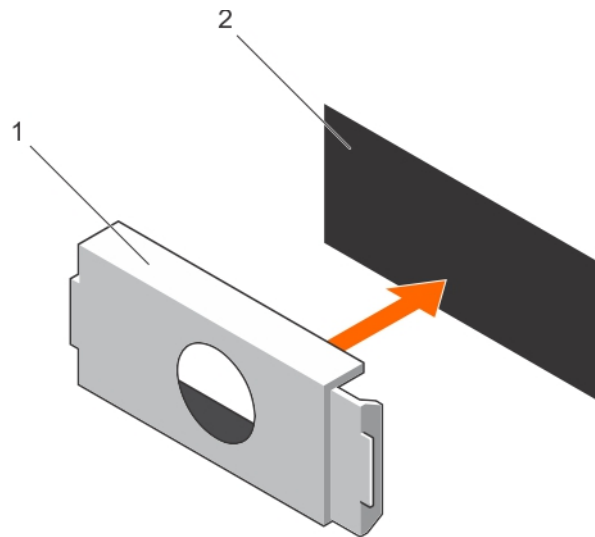

Figure 75. Installing the PSU blank

1 PSU blank

2 PSU bay

Related links

[Safety instructions](#)

[Removing the power supply unit blank](#)

System battery

The system board battery is used for low-level system functions like powering the real-time clock and storing the computer's BIOS settings.

Replacing the system battery

Prerequisites

- ⚠ WARNING:** There is a danger of a new battery exploding if it is incorrectly installed. Replace the battery only with the same or equivalent type recommended by the manufacturer. For more information, see the safety information that shipped with your system.
- ⚠ CAUTION:** Many repairs may only be done by a certified service technician. You should only perform troubleshooting and simple repairs as authorized in your product documentation, or as directed by the online or telephone service and support team. Damage due to servicing that is not authorized by Dell is not covered by your warranty. Read and follow the safety instructions that are shipped with your product.

- 1 Follow the safety guidelines listed in the Safety instructions section.
- 2 Follow the procedure listed in the Before working inside your system section.
- 3 Remove the cooling shroud.

Steps

- 1 Locate the battery socket. For more information, see the System board jumpers and connectors section.
 - ⚠ CAUTION:** To avoid damage to the battery connector, you must firmly support the connector while installing or removing a battery.
- 2 Place your finger between the securing tabs at the negative side of the battery connector and lift the battery out of the socket.

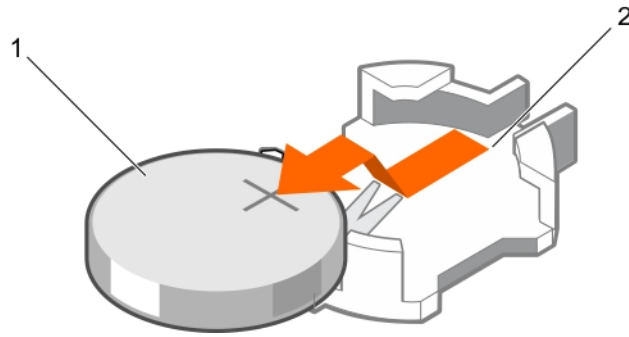

Figure 76. Removing the system battery

1 system battery

2 system battery slot

- 3 To install a new system battery, hold the battery with the "+" facing up and slide it under the securing tabs.
- 4 Press the battery into the connector until it snaps into place.

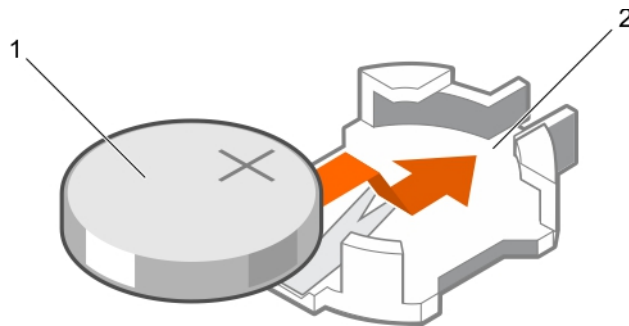

Figure 77. Installing the system battery

1 system battery

2 system battery slot

Next steps

- 1 Install the cooling shroud.
- 2 Follow the procedure listed in the After working inside your system section.
- 3 While booting, press F2 to enter System Setup and ensure the battery is operating properly.
- 4 Enter the correct time and date in the System Setup **Time** and **Date** fields.
- 5 Exit System Setup.

Related links

- [Safety instructions](#)
- [After working inside your system](#)
- [Before working inside your system](#)
- [Removing the cooling shroud](#)

Hard drive backplane

Depending on the configuration, your system supports one of the following:

- 3.5 inch x8 SAS/SATA backplane
- 3.5 inch x18 SAS/SATA backplane
- 2.5 inch x4 Dell PowerEdge Express Flash (PCIe SSD) backplane

- 2.5 inch x16 SAS/SATA backplane
- 2.5 inch x32 SAS/SATA backplane

Depending on the configuration, your system supports one of the following backplane combinations:

- 3.5 inch x8 SAS/SATA backplane and 2.5 inch x4 PCIe SSD backplane
- 2.5 inch x16 SAS/SATA backplane and 2.5 inch x4 PCIe SSD backplane
- 2.5 inch x16 SAS/SATA backplane for hard-drives in the hard drive bay and 2.5 inch x16 SAS/SATA backplane for hard-drives in a flex bay.

Removing the hard drive backplane

Prerequisites

- 1 Follow the safety guidelines listed in the safety instructions section.
- 2 Follow the procedure listed in the Before working inside your system section.
- 3 Remove all hard drives.
- 4 Remove the cooling shroud.
- 5 If applicable, remove the cooling-fan assembly.

⚠ CAUTION: Many repairs may only be done by a certified service technician. You should only perform troubleshooting and simple repairs as authorized in your product documentation, or as directed by the online or telephone service and support team. Damage due to servicing that is not authorized by Dell is not covered by your warranty. Read and follow the safety instructions that are shipped with your product.

⚠ CAUTION: To prevent damage to the drives and backplane, you must remove the hard drives from the system before removing the backplane.

⚠ CAUTION: You must note the number of each hard drive and temporarily label them before removal so that you can replace them in the same locations.

Steps

- 1 Disconnect the SAS/SATA/SSD data, signal, and power cable(s) from the backplane.
- 2 Pull the release pin or the release tab and pull the backplane up and out from the system.

📌 NOTE: For a Dell PowerEdge Express Flash (PCIe SSD) backplane, press the release tab to unlock the hard-drive backplane and release it from the hard-drive bay.

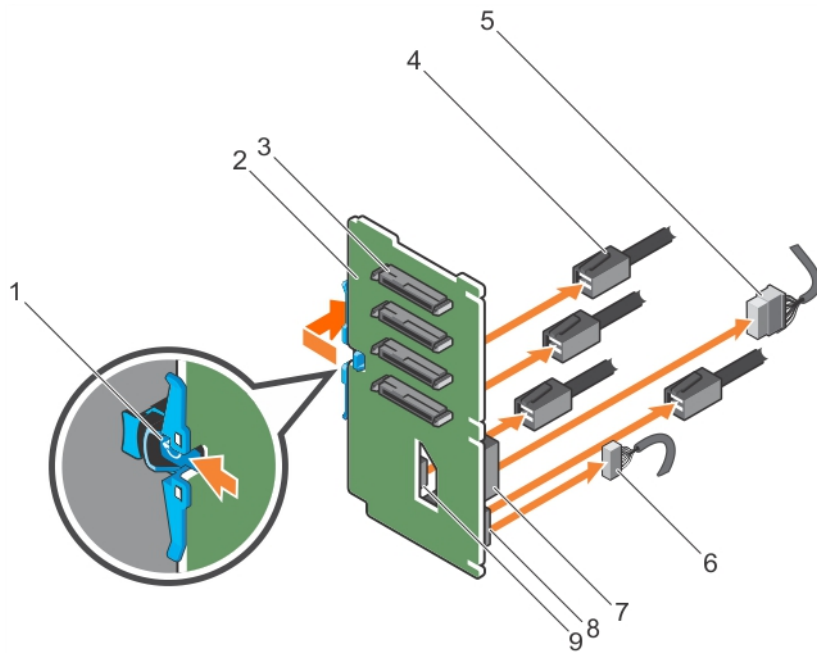

Figure 78. Removing the PCIe SSD hard drive backplane

- | | | | |
|---|-----------------------------------|---|-------------------------------------|
| 1 | release tab | 2 | PCIe SSD hard drive backplane |
| 3 | hard-drive connector | 4 | PCIe cable |
| 5 | power cable | 6 | signal cable |
| 7 | power connector on backplane | 8 | signal cable connector on backplane |
| 9 | PCIe cable connector on backplane | | |

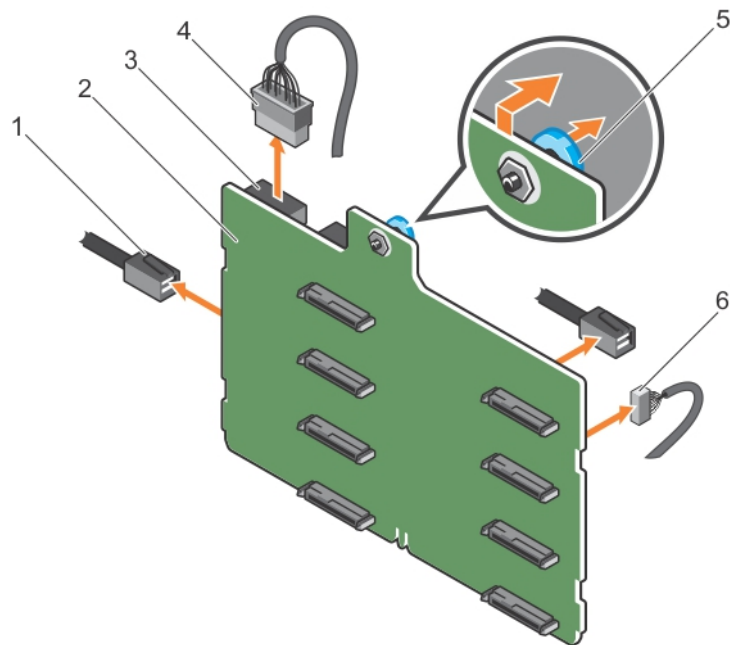

Figure 79. Removing a 3.5 inch (x8) SAS/SATA backplane

- | | | | |
|---|-----------|---|--------------|
| 1 | SAS cable | 2 | x8 backplane |
|---|-----------|---|--------------|

- 3 backplane power connector
- 4 backplane power cable
- 5 release pin
- 6 signal cable

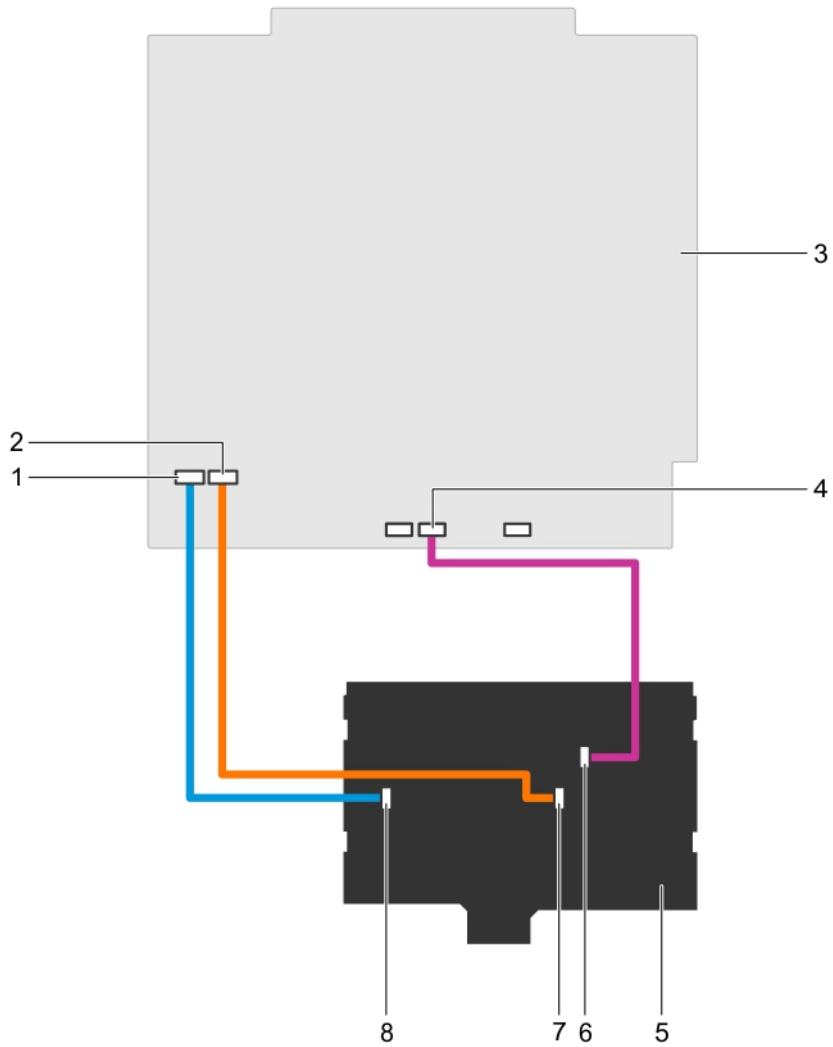

Figure 80. Cabling—3.5 inch (x8) SAS/SATA backplane

- 1 SAS A connector on system board
- 2 SAS B connector on system board
- 3 system board
- 4 signal connector on system board
- 5 x8 backplane
- 6 signal connector on backplane
- 7 SAS B connector on backplane
- 8 SAS A connector on backplane

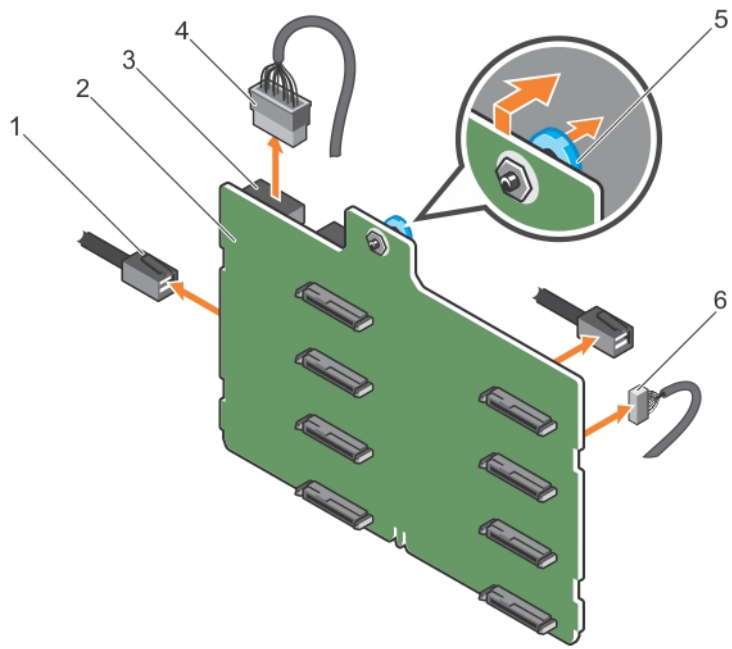

Figure 81. Removing a 3.5 inch (x8) SAS/SATA backplane with a single PERC card

- | | | | |
|---|-----------------|---|--------------|
| 1 | SAS cable | 2 | x8 backplane |
| 3 | power connector | 4 | power cable |
| 5 | release pin | 6 | signal cable |

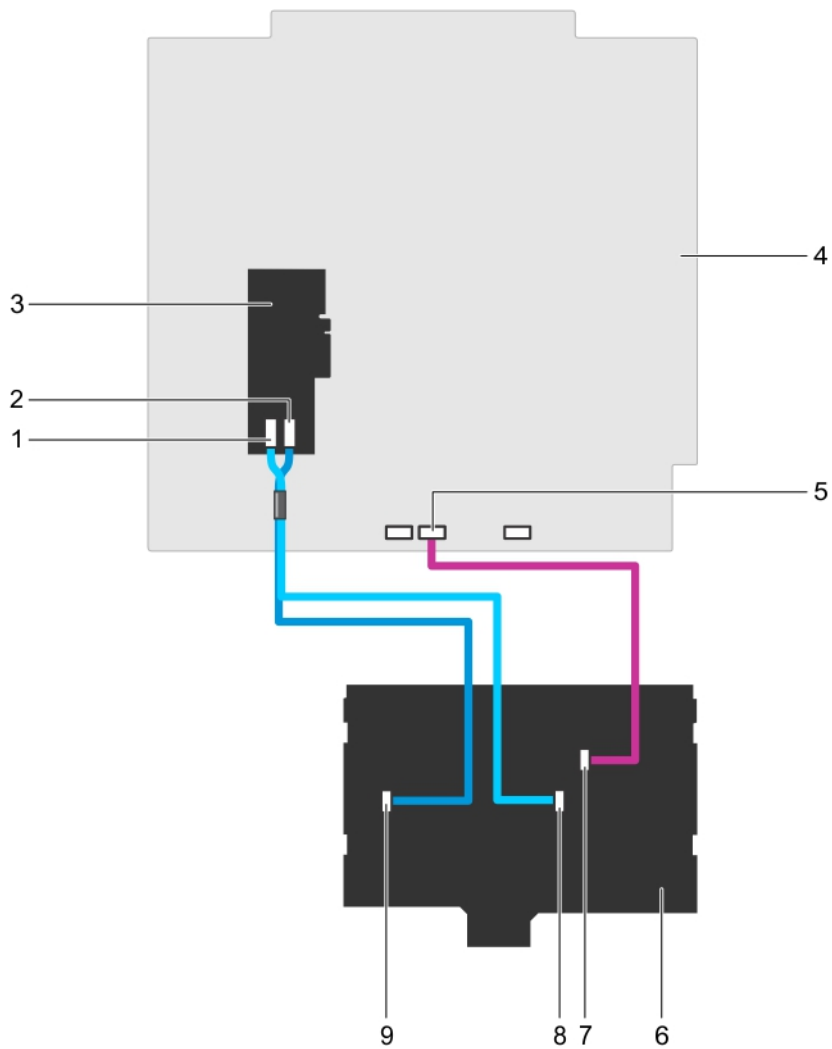

Figure 82. Cabling—3.5 inch (x8) SAS/SATA backplane with a single PERC card

- | | | | |
|---|----------------------------------|---|------------------------------|
| 1 | SAS B connector on PERC card | 2 | SAS A connector on PERC card |
| 3 | PERC card | 4 | system board |
| 5 | signal connector on system board | 6 | x8 backplane |
| 7 | signal connector on backplane | 8 | SAS B connector on backplane |
| 9 | SAS A connector on backplane | | |

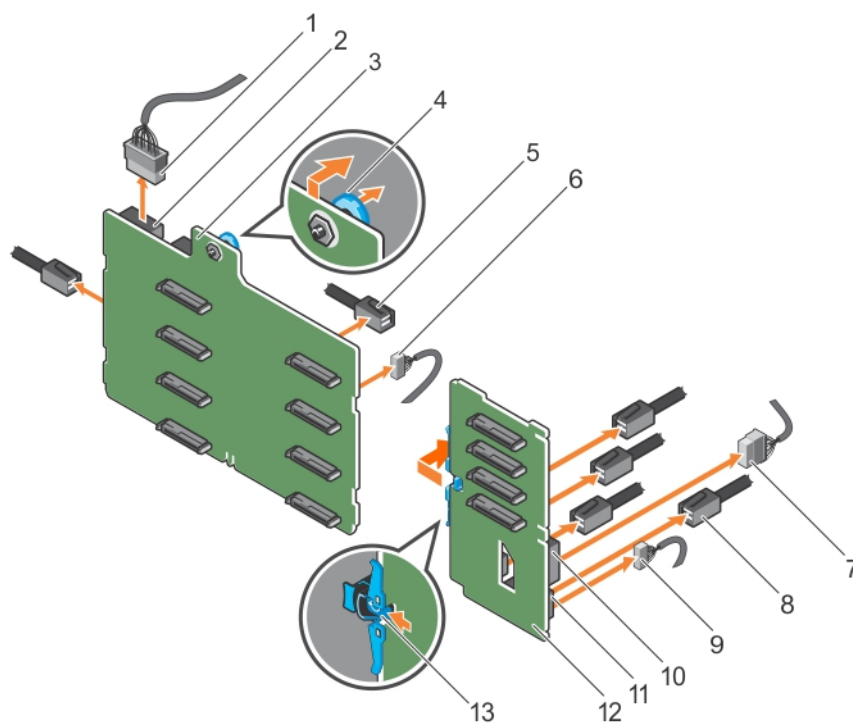

Figure 83. Removing a 3.5 inch (x8) plus 2.5 Inch (x4) SAS/SATA backplane

- | | | | |
|----|--|----|---------------------------------------|
| 1 | x8 backplane power cable | 2 | power connector on x8 backplane |
| 3 | x8 backplane | 4 | release pin |
| 5 | SAS cable on x8 backplane | 6 | signal cable on x8 backplane |
| 7 | power cable on PCIe SSD backplane | 8 | PCIe cable on PCIe SSD backplane |
| 9 | signal cable on PCIe SSD backplane | 10 | power connector on PCIe SSD backplane |
| 11 | signal connector on PCIe SSD backplane | 12 | PCIe SSD backplane |
| 13 | release tab | | |

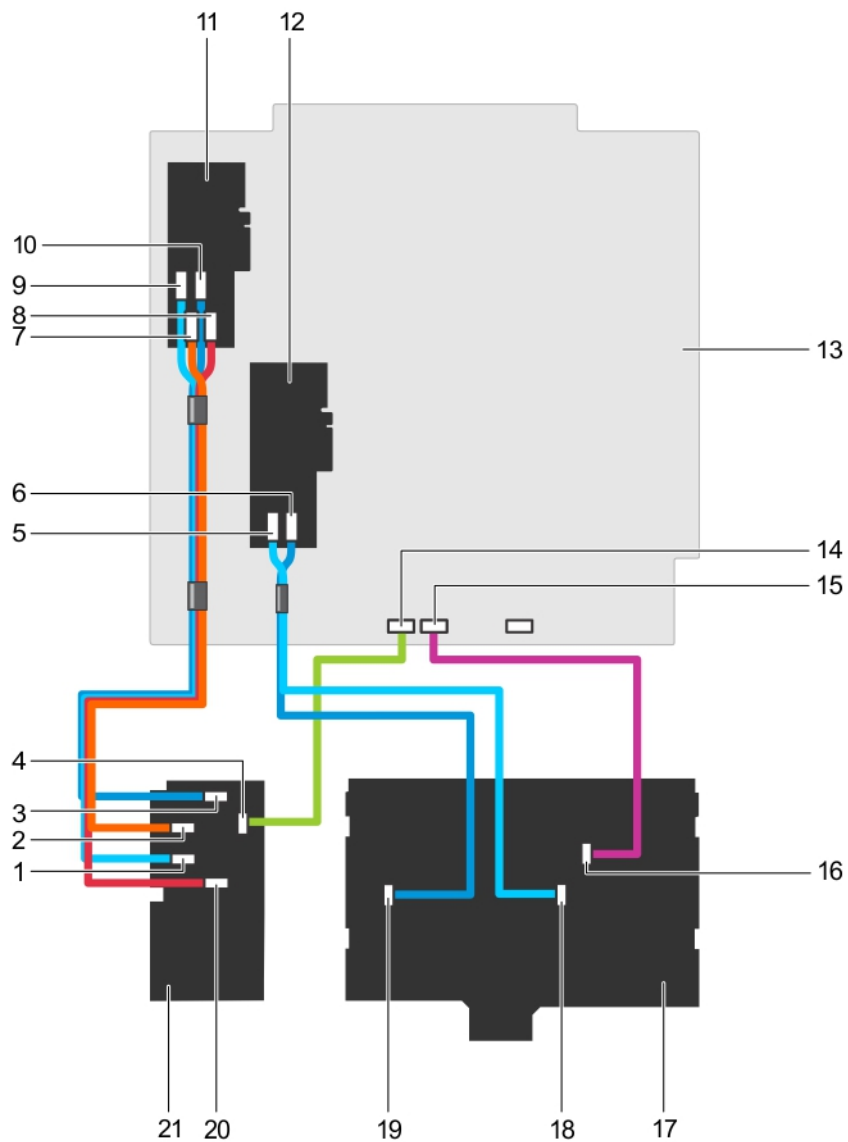

Figure 84. Cabling—3.5 Inch (x8) plus 2.5 inch (x4) SAS/SATA backplane

- | | | | |
|----|--|----|--|
| 1 | PCIe C connector on PCIe SSD backplane | 2 | PCIe B connector on PCIe SSD backplane |
| 3 | PCIe A connector on PCIe SSD backplane | 4 | PCIe SSD backplane signal connector |
| 5 | SAS B cable from 3.5 inch backplane on PERC card | 6 | SAS A cable from 3.5 inch backplane on PERC card |
| 7 | PCIe C connector from PCIe SSD backplane to PCIe extender card | 8 | PCIe A connector from PCIe SSD backplane to PCIe extender card |
| 9 | PCIe D connector from PCIe SSD backplane to PCIe extender card | 10 | PCIe B connector from PCIe SSD backplane to PCIe extender card |
| 11 | PCIe bridge card | 12 | PERC card 2 |
| 13 | System Board | 14 | PCIe SSD backplane signal connector on system board |
| 15 | x8 backplane signal connector on system board | 16 | x8 backplane signal connector |
| 17 | 3.5-inch x8 backplane | 18 | SAS B connector on x8 backplane |

19 SAS A connector on x8 backplane

20 PCIe D connector on PCIe SSD backplane

21 PCIe SSD backplane

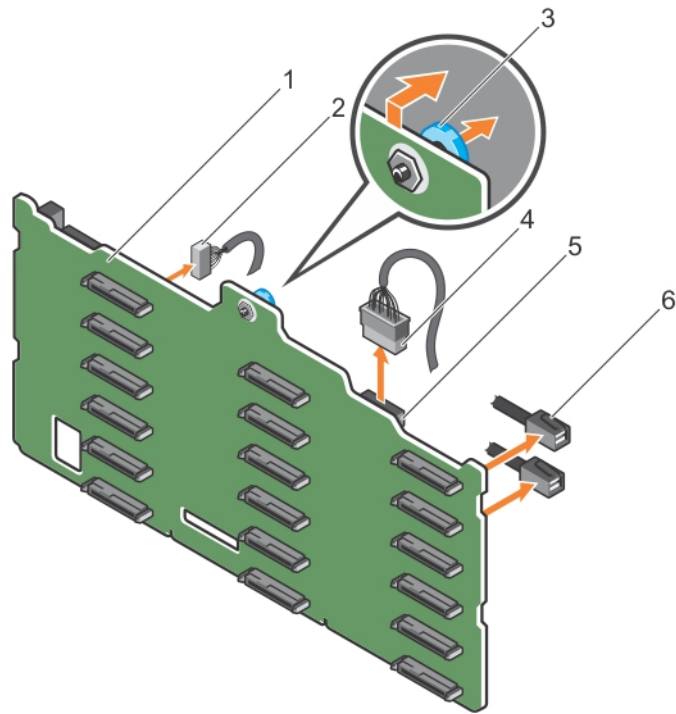

Figure 85. Removing a 3.5 inch (x18) SAS/SATA backplane

1 x18 backplane

2 signal cable

3 release pin

4 power cable

5 power connector

6 SAS cable

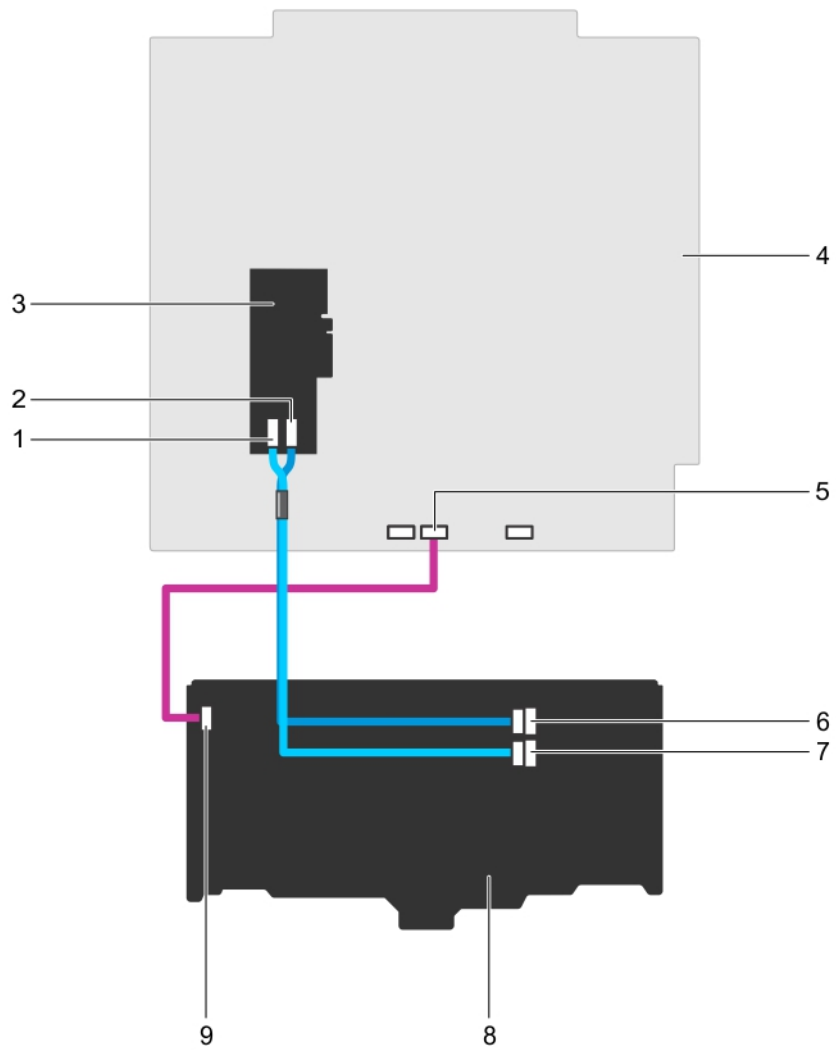

Figure 86. Cabling—3.5 inch (x18) SAS/SATA backplane

- | | |
|------------------------------------|--------------------------------|
| 1 SAS B connector on PERC card | 2 SAS A connector on PERC card |
| 3 PERC card | 4 System board |
| 5 signal connector on system board | 6 SAS A connector on backplane |
| 7 SAS B connector on backplane | 8 x18 backplane |
| 9 signal connector on backplane | |

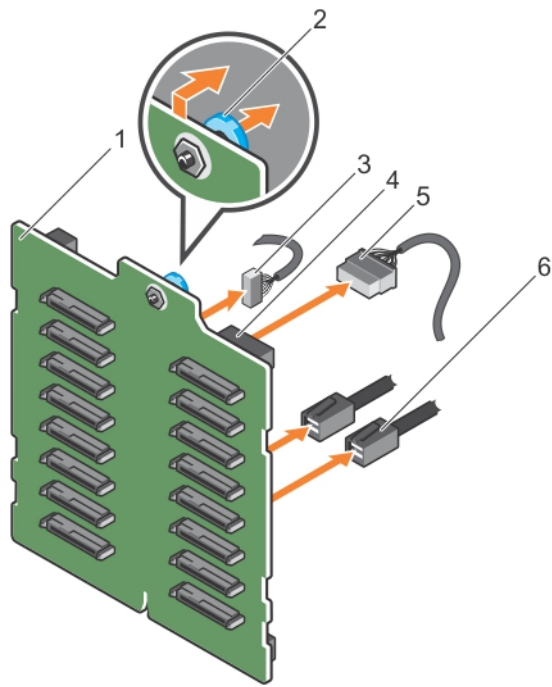

Figure 87. Removing a 2.5 inch (x16) SAS/SATA backplane

- | | | | |
|---|---------------|---|-----------------|
| 1 | x16 backplane | 2 | release pin |
| 3 | signal cable | 4 | power connector |
| 5 | power cable | 6 | SAS cable |

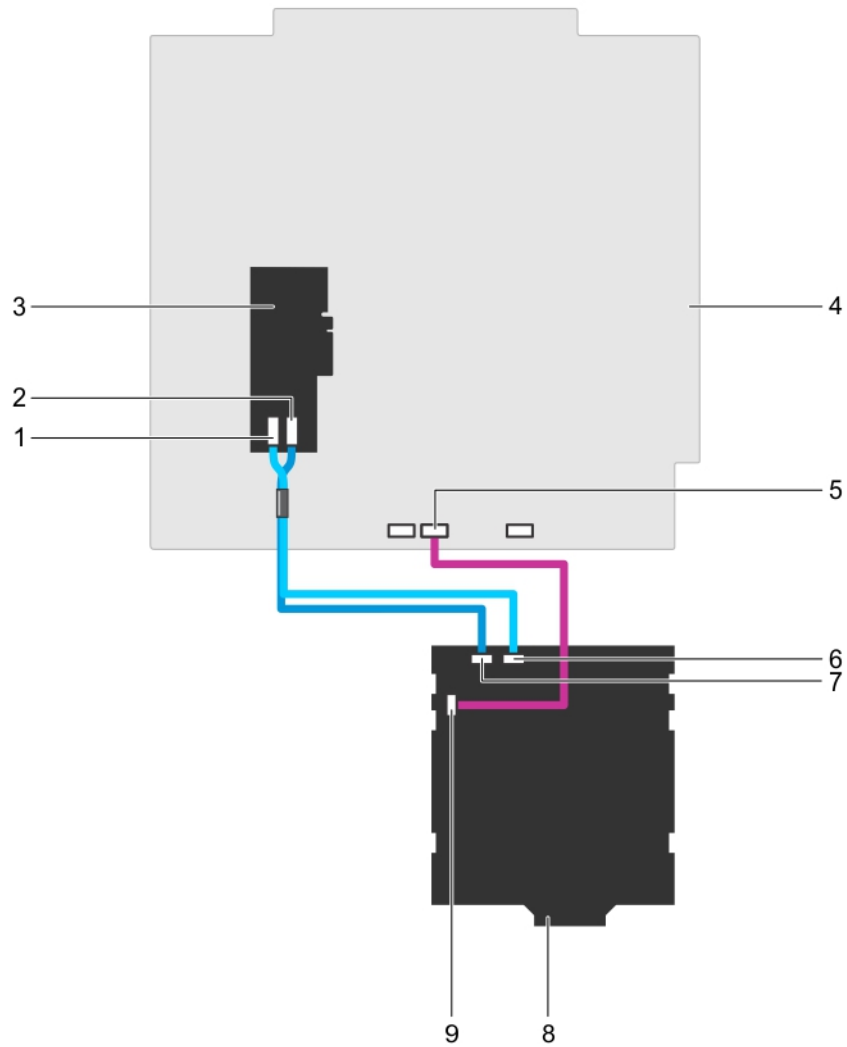

Figure 88. Cabling—2.5 inch (x16) SAS/SATA backplane

- | | | | |
|---|----------------------------------|---|------------------------------|
| 1 | SAS B connector on PERC card | 2 | SAS A connector on PERC card |
| 3 | PERC card | 4 | system board |
| 5 | signal connector on system board | 6 | SAS B connector on backplane |
| 7 | SAS A connector on backplane | 8 | x16 backplane |
| 9 | signal connector on backplane | | |

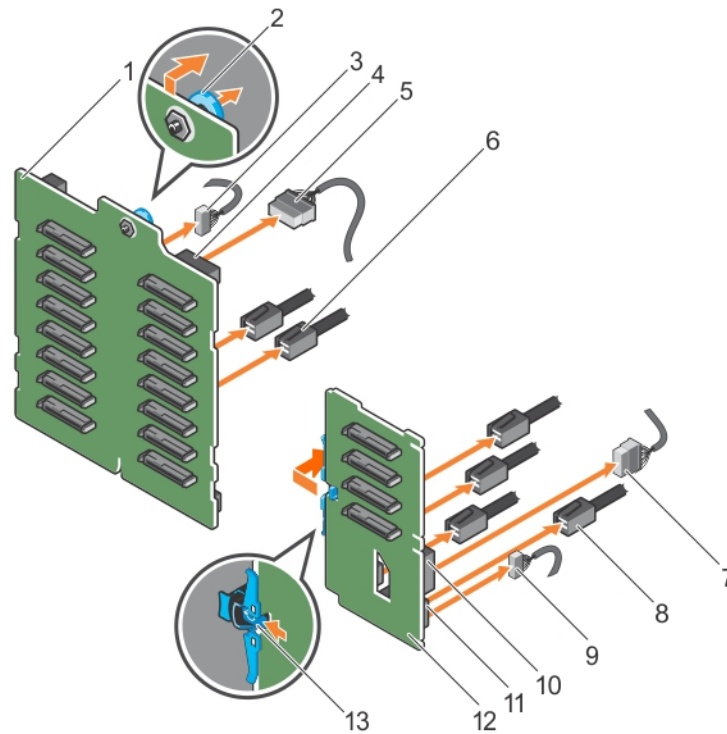

Figure 89. Removing a 2.5 inch (x16) plus 2.5 Inch (x4) SAS/SATA backplane

- | | | | |
|----|--|----|---------------------------------------|
| 1 | x16 backplane | 2 | release pin |
| 3 | signal cable to x16 backplane | 4 | power connector on x16 backplane |
| 5 | power cable to x16 backplane | 6 | SAS cable to x16 backplane |
| 7 | power cable to PCIe SSD backplane | 8 | PCIe cable to PCIe SSD backplane |
| 9 | signal cable to PCIe SSD backplane | 10 | power connector on PCIe SSD backplane |
| 11 | signal connector on PCIe SSD backplane | 12 | PCIe SSD backplane |
| 13 | release tab | | |

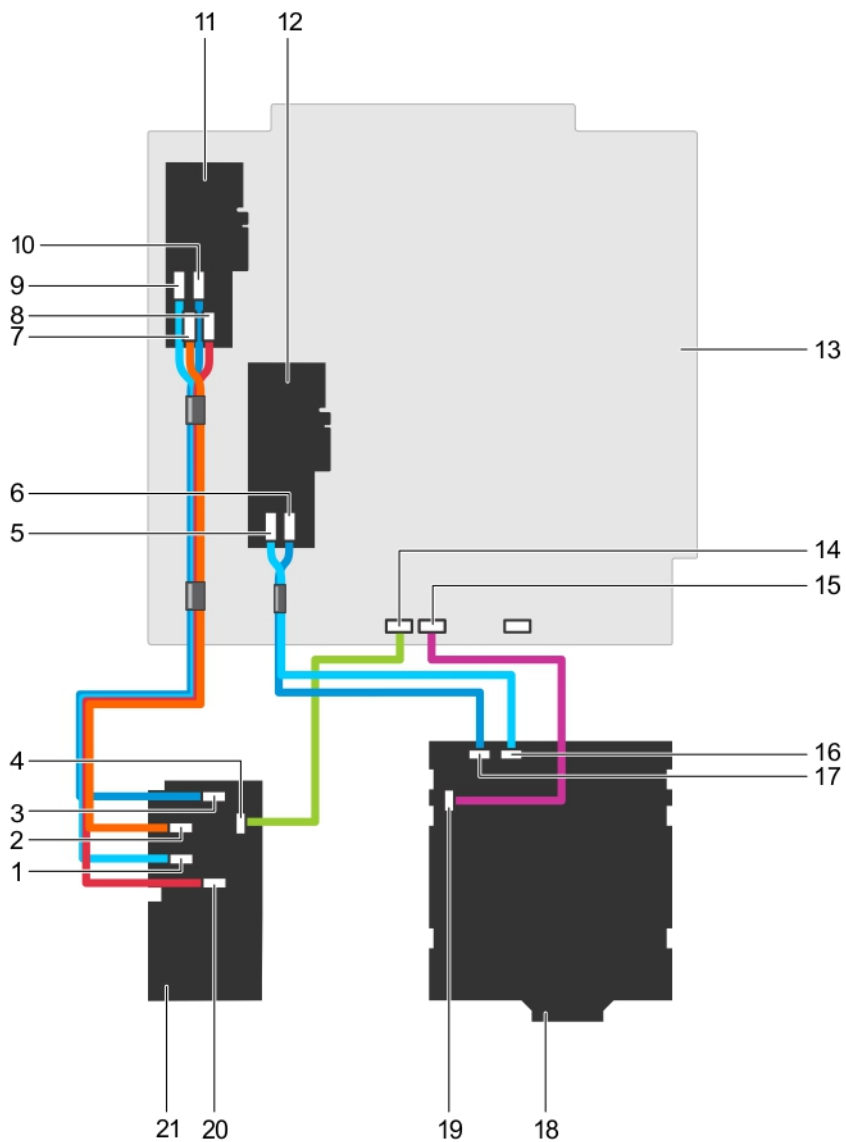

Figure 90. Cabling—2.5 inch (x16) plus 2.5 inch (x4) SAS/SATA backplane

- | | | | |
|----|--|----|--|
| 1 | PCIe C connector on PCIe SSD backplane | 2 | PCIe B connector on PCIe SSD backplane |
| 3 | PCIe A connector on PCIe SSD backplane | 4 | PCIe SSD backplane signal connector |
| 5 | SAS B cable from 2.5 inch backplane on PERC card | 6 | SAS A cable from 2.5 inch backplane on PERC card |
| 7 | PCIe C connector from PCIe SSD backplane to PCIe extender card | 8 | PCIe A connector from PCIe SSD backplane to PCIe extender card |
| 9 | PCIe D connector from PCIe SSD backplane to PCIe extender card | 10 | PCIe B connector from PCIe SSD backplane to PCIe extender card |
| 11 | PCIe bridge card | 12 | PERC card 2 |
| 13 | System Board | 14 | PCIe SSD backplane signal connector on system board |
| 15 | x16 backplane signal connector on system board | 16 | SAS B cable on x16 backplane |
| 17 | SAS A cable on x16 backplane | 18 | 2.5-inch x16 backplane |

19 x16 backplane signal cable

20 PCIe D connector on PCIe SSD backplane

21 PCIe SSD backplane

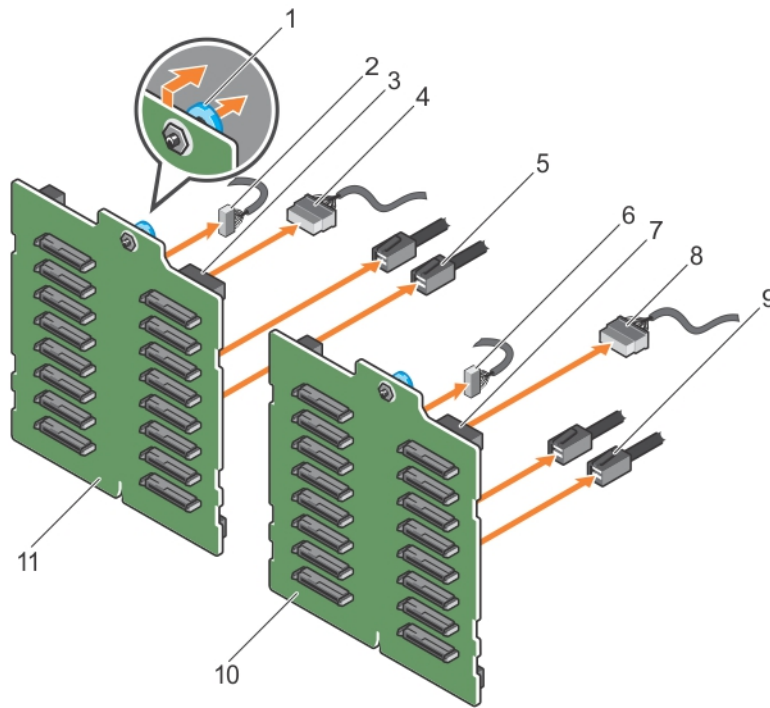

Figure 91. Removing a 2.5 inch (x32) SAS/SATA backplane with two PERC cards

- | | | | |
|----|--------------------------------|----|-----------------------------|
| 1 | release pin | 2 | signal cable to backplane 2 |
| 3 | power connector on backplane 2 | 4 | power cable to backplane 2 |
| 5 | SAS cable to backplane 2 | 6 | signal cable to backplane 1 |
| 7 | power connector on backplane 1 | 8 | power cable to backplane 1 |
| 9 | SAS cable to backplane 1 | 10 | backplane 1 |
| 11 | backplane 2 | | |

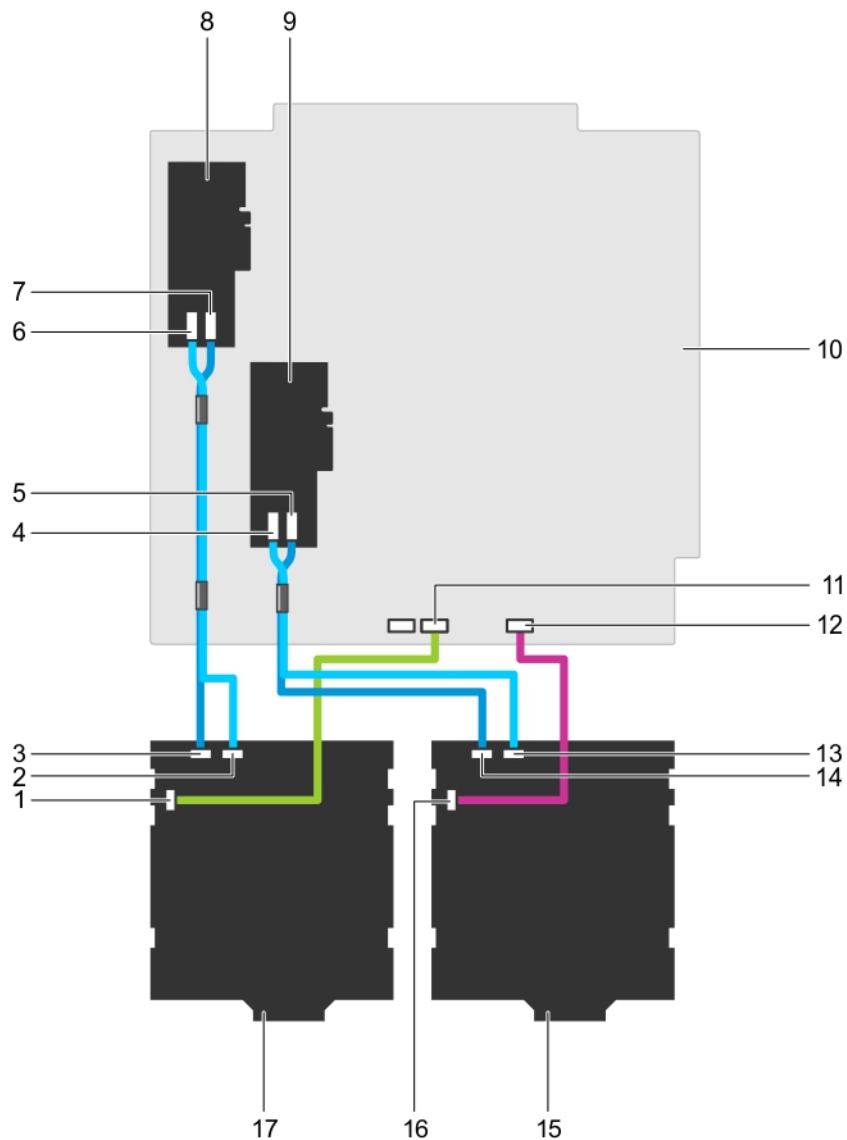

Figure 92. Cabling—2.5 inch (x32) SAS/SATA backplane with two PERC cards

- | | | | |
|----|---|----|---|
| 1 | signal connector on backplane 2 | 2 | SAS B connector on backplane 2 |
| 3 | SAS A connector on backplane 2 | 4 | SAS B connector on PERC 1 |
| 5 | SAS A connector on PERC 1 | 6 | SAS B connector on PERC 2 |
| 7 | SAS A connector on PERC 2 | 8 | PERC card 2 |
| 9 | PERC card 1 | 10 | system board |
| 11 | signal cable from backplane 2 on system board | 12 | signal cable from backplane 1 on system board |
| 13 | SAS B connector on backplane 1 | 14 | SAS A connector on backplane 1 |
| 15 | backplane 1 | 16 | signal connector on backplane 1 |
| 17 | backplane 2 | | |

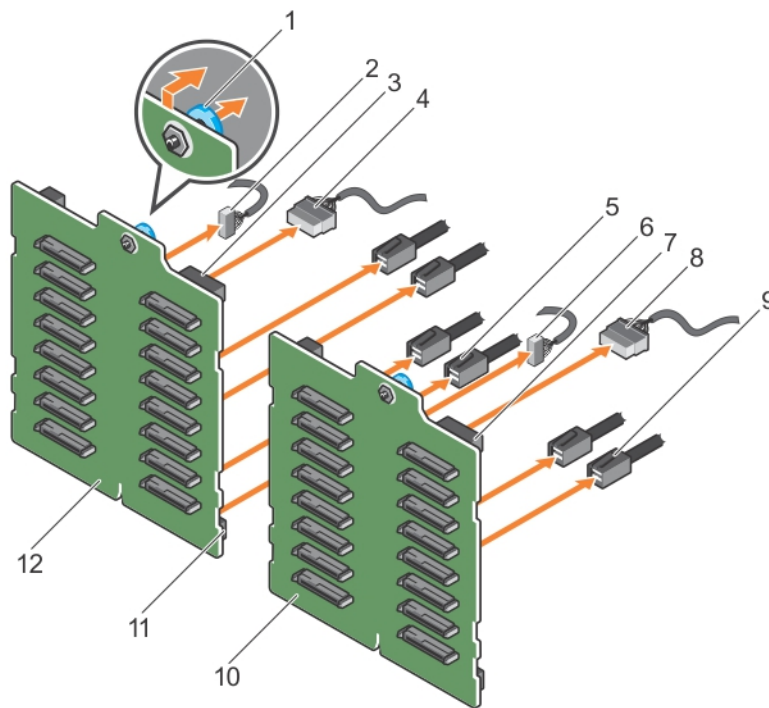

Figure 93. Removing 2.5 inch (x32) SAS/SATA backplane with a single PERC card

- | | | | |
|----|--------------------------------|----|-----------------------------|
| 1 | release pin | 2 | signal cable to backplane 2 |
| 3 | power connector on backplane 2 | 4 | power cable to backplane 2 |
| 5 | SAS cable to backplane 2 | 6 | signal cable to backplane 1 |
| 7 | power connector on backplane 1 | 8 | power cable to backplane 1 |
| 9 | SAS cable to backplane 1 | 10 | x16 backplane 1 |
| 11 | SAS connector on backplane 2 | 12 | x16 backplane 2 |

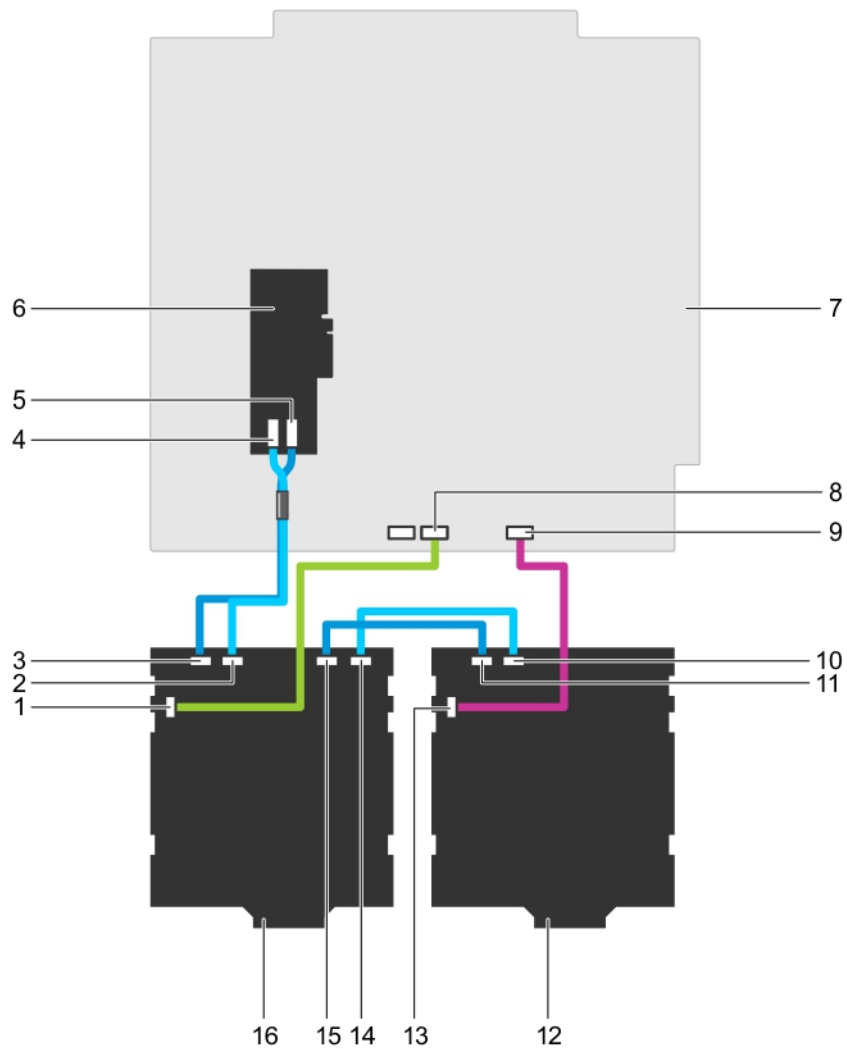

Figure 94. Cabling—2.5 inch (x32) SAS/SATA backplane with a single PERC card

- | | | | |
|----|--|----|--|
| 1 | signal connector on backplane 2 | 2 | SAS B connector on backplane 2 |
| 3 | SAS A connector on backplane 2 | 4 | SAS B connector on PERC card |
| 5 | SAS A connector on PERC card | 6 | x32 PERC card |
| 7 | system board | 8 | backplane 2 signal connector on system board |
| 9 | backplane 1 signal connector on system board | 10 | SAS B connector on backplane 1 |
| 11 | SAS A connector on backplane 1 | 12 | backplane 1 |
| 13 | signal connector on backplane 1 | 14 | SAS B1 connector on backplane 2 |
| 15 | SAS A1 connector on backplane 2 | 16 | backplane 2 |

Related links

- [Safety instructions](#)
- [Before working inside your system](#)
- [Removing the cooling shroud](#)
- [Removing the optional cooling fan assembly](#)

Installing the hard drive backplane

Prerequisites

⚠ CAUTION: Many repairs may only be done by a certified service technician. You should only perform troubleshooting and simple repairs as authorized in your product documentation, or as directed by the online or telephone service and support team. Damage due to servicing that is not authorized by Dell is not covered by your warranty. Read and follow the safety instructions that are shipped with your product.

- 1 Follow the safety guidelines listed in safety instructions section.
- 2 Follow the procedure listed in the Before working inside your system section.
- 3 Remove all the hard drives. For more information, see the Removing a hot swap hard drive section.
- 4 If applicable, remove the cooling-fan assembly. For more information, see the Removing the cooling-fan assembly (optional) section.
- 5 Remove the cooling shroud. For more information, see the Removing the cooling shroud section.

Steps

- 1 Use the hooks at the base of the chassis as guides to align the hard drive backplane.
- 2 Lower the hard-drive backplane into the chassis to secure the hard drive backplane into place.
i NOTE: For a Dell PowerEdge Express Flash (PCIe SSD) backplane, lower the hard-drive backplane into the chassis until the release tab snaps into place.
- 3 Connect the SAS/SATA/SSD data, signal, and power cable(s) to the backplane. See the cabling instructions provided in this document.

Next steps

- 1 If applicable, install the cooling-fan assembly. For more information, see the Installing the cooling-fan assembly (optional) section.
- 2 Install the cooling shroud. For more information, see the Installing the cooling shroud section.
- 3 Install the hard drives in their original locations.
- 4 Follow the procedure listed in the After working inside your system section.

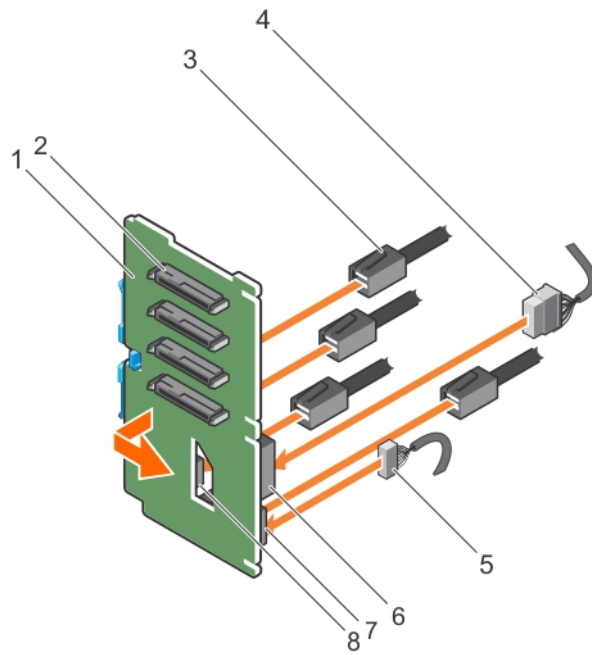

Figure 95. Installing the PCIe SSD hard drive backplane

- | | | | |
|---|-------------------------------------|---|-----------------------------------|
| 1 | PCIe SSD hard drive backplane | 2 | PCIe SSD hard drive connector |
| 3 | PCIe cable | 4 | power cable |
| 5 | signal cable | 6 | power connector on backplane |
| 7 | signal cable connector on backplane | 8 | PCIe cable connector on backplane |

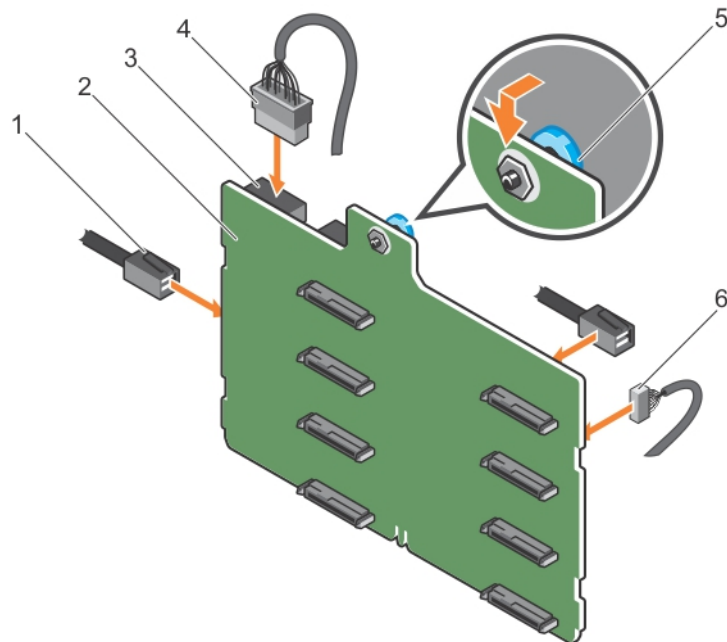

Figure 96. Installing a 3.5 inch (x8) SAS/SATA backplane

- | | | | |
|---|---------------------------|---|-----------------------|
| 1 | SAS cable | 2 | x8 backplane |
| 3 | backplane power connector | 4 | backplane power cable |

5 Release pin

6 signal cable

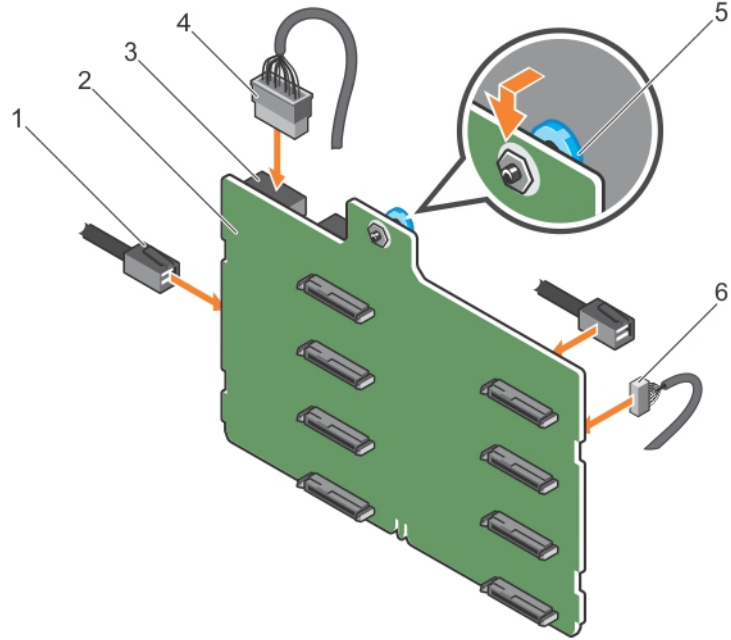

Figure 97. Installing a 3.5 inch (x8) SAS/SATA backplane with a single PERC card

1 SAS cable

2 x8 backplane

3 power connector

4 power cable

5 release pin

6 signal cable

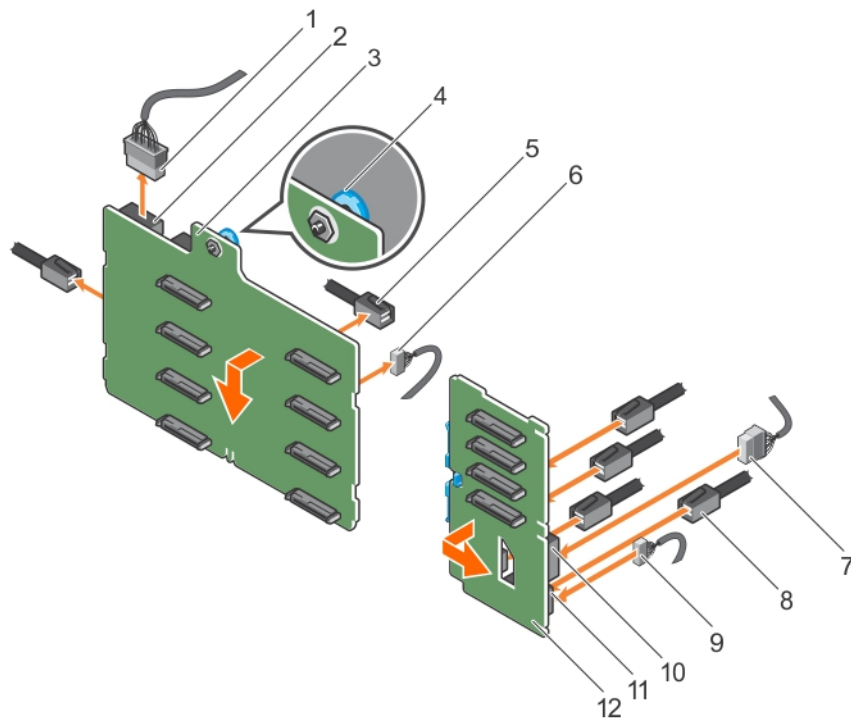

Figure 98. Installing a 3.5 inch (x8) plus 2.5 Inch (x4) SAS/SATA backplane

- | | | | |
|----|--|----|---------------------------------------|
| 1 | x8 backplane power cable | 2 | power connector on x8 backplane |
| 3 | x8 backplane | 4 | release pin |
| 5 | SAS cable on x8 backplane | 6 | signal cable on x8 backplane |
| 7 | power cable on PCIe SSD backplane | 8 | PCIe cable on PCIe SSD backplane |
| 9 | signal cable on PCIe SSD backplane | 10 | power connector on PCIe SSD backplane |
| 11 | signal connector on PCIe SSD backplane | 12 | PCIe SSD backplane |

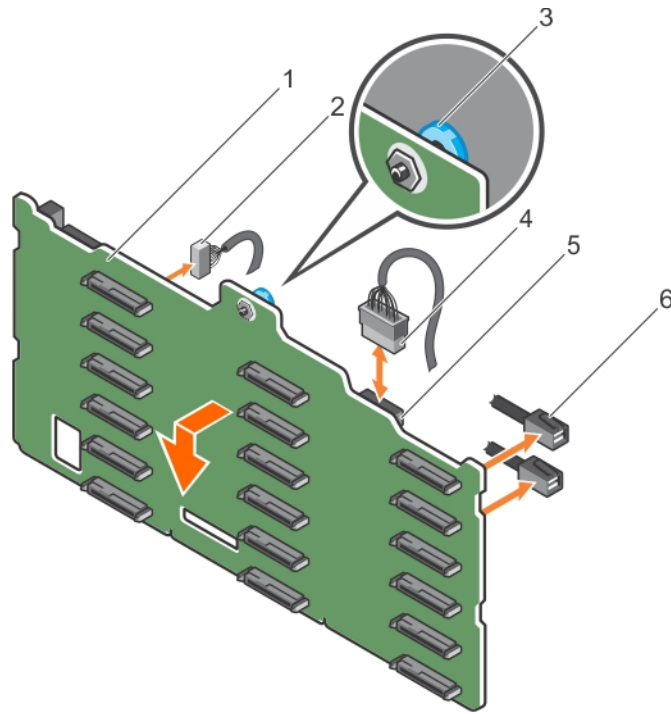

Figure 99. Installing a 3.5 inch (x18) SAS/SATA backplane

- | | | | |
|---|-----------------|---|--------------|
| 1 | x18 backplane | 2 | signal cable |
| 3 | release pin | 4 | power cable |
| 5 | power connector | 6 | SAS cable |

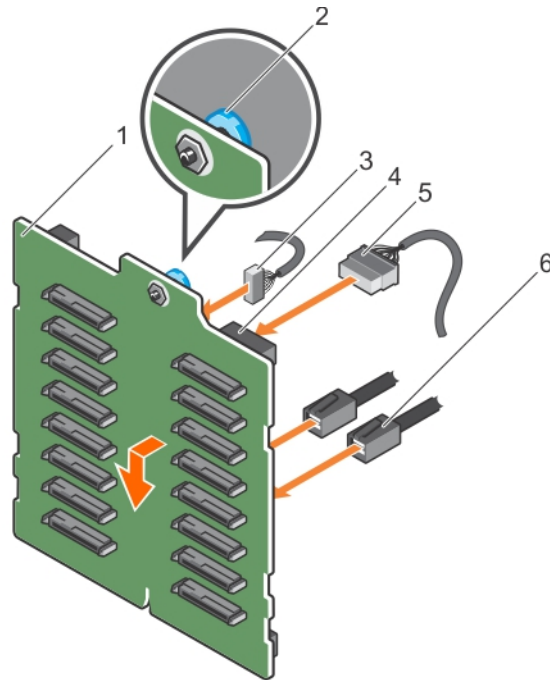

Figure 100. Installing a 2.5 inch (x16) SAS/SATA backplane

- | | | | |
|---|---------------|---|-------------|
| 1 | x16 backplane | 2 | release pin |
|---|---------------|---|-------------|

- 3 signal cable
- 4 power connector
- 5 power cable
- 6 SAS cable

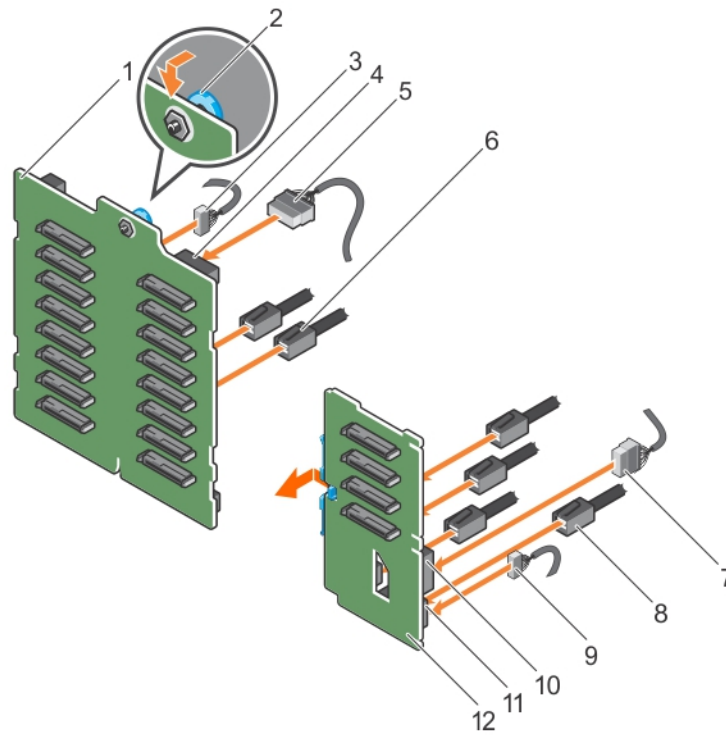

Figure 101. Installing a 2.5 inch (x16) plus 2.5 inch (x4) SAS/SATA backplane

- 1 x16 backplane
- 2 release pin
- 3 signal cable to x16 backplane
- 4 power connector on x16 backplane
- 5 power cable to x16 backplane
- 6 SAS cable to x16 backplane
- 7 power cable to PCIe SSD backplane
- 8 PCIe cable to PCIe SSD backplane
- 9 signal cable to PCIe SSD backplane
- 10 power connector on PCIe SSD backplane
- 11 signal connector on PCIe SSD backplane
- 12 PCIe SSD backplane

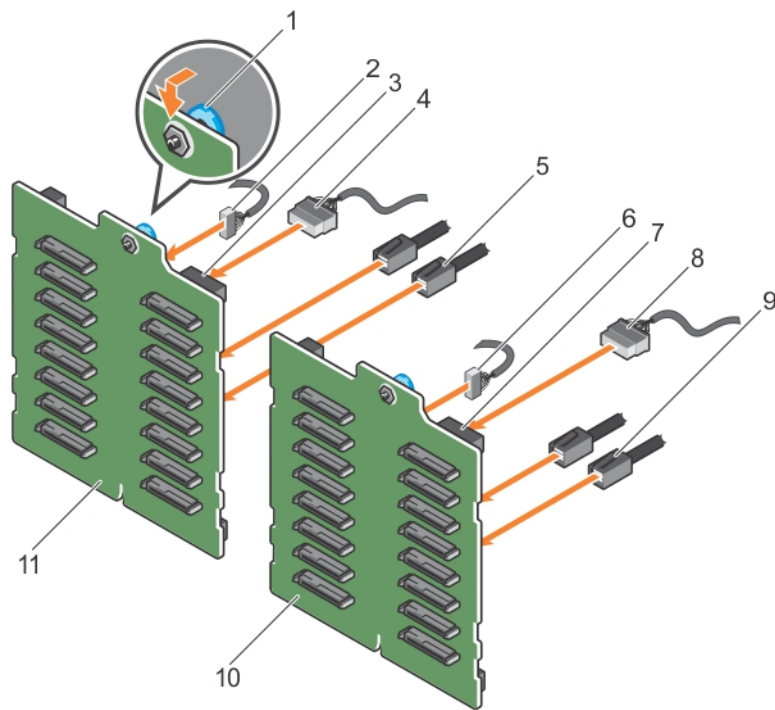

Figure 102. Installing a 2.5 inch (x32) SAS/SATA backplane with two PERC cards

- | | | | |
|----|--------------------------------|----|-----------------------------|
| 1 | release pin | 2 | signal cable to backplane 2 |
| 3 | power connector on backplane 2 | 4 | power cable to backplane 2 |
| 5 | SAS cable to backplane 2 | 6 | signal cable to backplane 1 |
| 7 | power connector on backplane 1 | 8 | power cable to backplane 1 |
| 9 | SAS cable to backplane 1 | 10 | x16 backplane 1 |
| 11 | x16 backplane 2 | | |

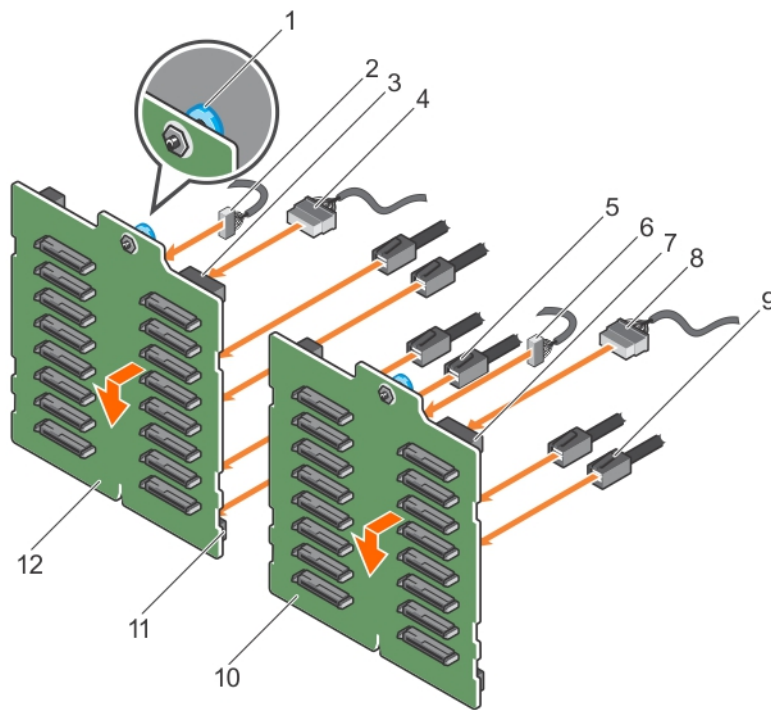

Figure 103. Installing a 2.5 inch (x32) SAS/SATA backplane with a single PERC card

- | | | | |
|----|--------------------------------|----|-----------------------------|
| 1 | release pin | 2 | signal cable to backplane 2 |
| 3 | power connector on backplane 2 | 4 | power cable to backplane 2 |
| 5 | SAS cable to backplane 2 | 6 | signal cable to backplane 1 |
| 7 | power connector on backplane 1 | 8 | power cable to backplane 1 |
| 9 | SAS cable to backplane 1 | 10 | x16 backplane 1 |
| 11 | SAS connector on backplane 2 | 12 | x16 backplane 2 |

Related links

- [Safety instructions](#)
- [Before working inside your system](#)
- [After working inside your system](#)
- [Safety instructions](#)
- [Before working inside your system](#)
- [Removing a hot swappable hard drive or SSD](#)
- [Installing the cooling shroud](#)
- [Installing the optional cooling fan assembly](#)

SD vFlash media card (optional)

An SD vFlash card is a Secure Digital (SD) card that plugs into the SD vFlash card slot in the iDRAC port card. It provides persistent on-demand local storage and a custom deployment environment that enables automation of server configuration, scripts, and imaging. It emulates USB device(s). For more information, see the Integrated Dell Remote Access Controller User's Guide at Dell.com/idracmanuals.

CAUTION: Many repairs may only be done by a certified service technician. You should only perform troubleshooting and simple repairs as authorized in your product documentation, or as directed by the online or telephone service and support team. Damage due to servicing that is not authorized by Dell is not covered by your warranty. Read and follow the safety instructions that are shipped with your product.

Steps

- 1 Remove the screw that secures control panel to the chassis.
- 2 Disconnect the control panel cable and the control panel USB cable from the system board.

CAUTION: Do not use excessive force when removing the control panel cables as it can damage the connectors.

- 3 Slide the control panel out of the chassis.

NOTE: Follow the same steps to remove the control panel in the rack-mode configuration.

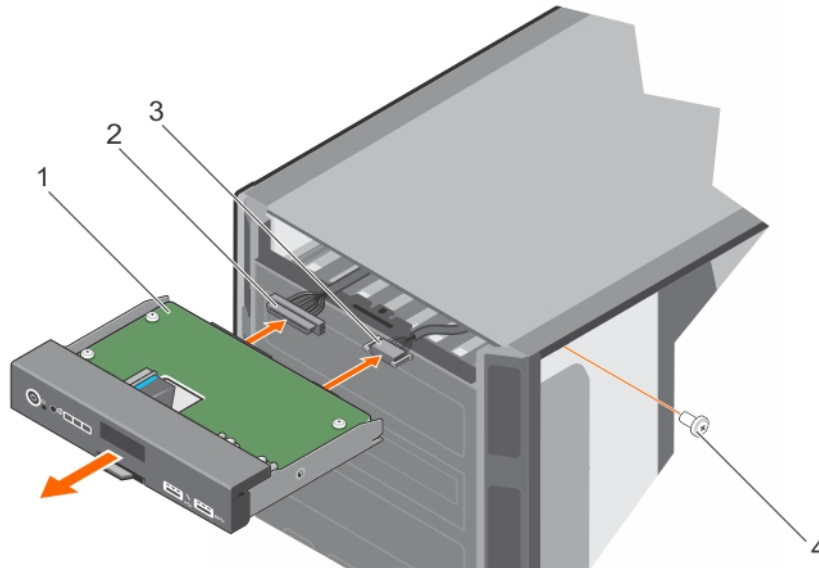

Figure 106. Removing the control panel assembly

- | | |
|---------------------------|-----------------------|
| 1 control panel | 2 control panel cable |
| 3 control panel USB cable | 4 screw |

- 4 To remove the information tag, perform the following steps:
 - a Locate and press the tabs on the information tag.
 - b Push the information tag out of the slot to remove it from the control panel.

NOTE: Retain the information tag to replace it in the new control panel.

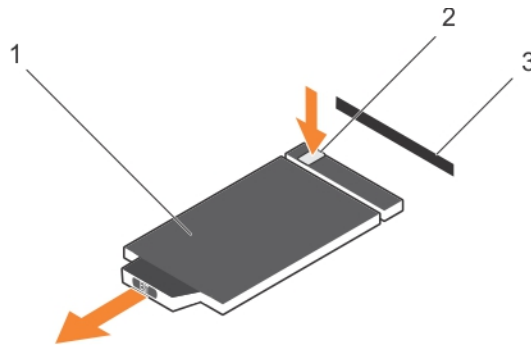

Figure 107. Removing the information tag

1 information tag
3 slot

2 tab

Related links

[Safety instructions](#)
[Before working inside your system](#)
[Installing the control panel assembly](#)
[Safety instructions](#)

Installing the control panel assembly

Prerequisites

⚠ CAUTION: Many repairs may only be done by a certified service technician. You should only perform troubleshooting and simple repairs as authorized in your product documentation, or as directed by the online or telephone service and support team. Damage due to servicing that is not authorized by Dell is not covered by your warranty. Read and follow the safety instructions that are shipped with your product.

- 1 Follow the safety guidelines listed in the safety instructions section.
- 2 Keep the Phillips #2 screwdriver ready.

Steps

- 1 Replace the blank information tag in the new control panel with the information tag retained from the old control panel.

ⓘ NOTE: An Information tag contains system information about the Service Tag, NIC, and MAC address etc.

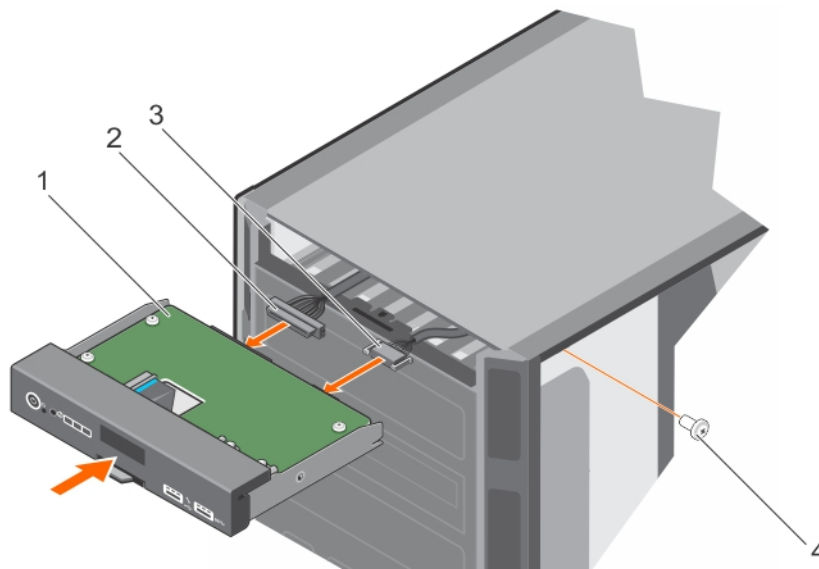

Figure 108. installing the control panel assembly

- | | | | |
|---|-------------------------|---|---------------------|
| 1 | control panel | 2 | control panel cable |
| 3 | control panel USB cable | 4 | screw |

- To install the information tag, push the information tag into the control-panel slot.

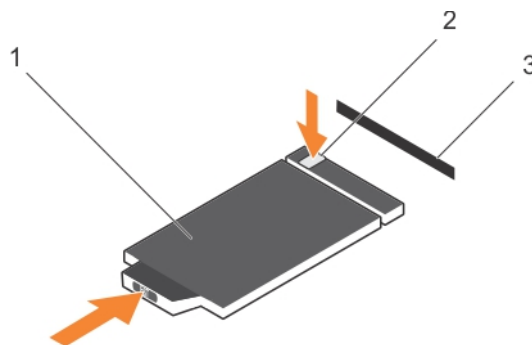

Figure 109. Installing the information tag

- | | | | |
|---|-----------------|---|-----|
| 1 | information tag | 2 | tab |
| 3 | slot | | |

- Connect the control panel cable and the control panel USB cable to the control panel assembly.
- Align and insert the control panel into the control panel slot in the chassis.
- Secure the control panel to the chassis by using the screw.
- Connect the control panel cable and the control panel USB cable to the system board.

Next steps

- If applicable, install the cooling fan assembly.
- Follow the procedure listed in the After working inside your system section.

Related links

- [Safety instructions](#)
- [After working inside your system](#)
- [Installing the optional cooling fan assembly](#)

System board

The system board has the connectors for your system components and also contains the integrated components.

Removing the system board

Prerequisites

- △ **CAUTION:** Many repairs may only be done by a certified service technician. You should only perform troubleshooting and simple repairs as authorized in your product documentation, or as directed by the online or telephone service and support team. Damage due to servicing that is not authorized by Dell is not covered by your warranty. Read and follow the safety instructions that are shipped with your product.
- △ **CAUTION:** If you are using the Trusted Platform Module (TPM) with an encryption key, you may be prompted to create a recovery key during program or System Setup. Be sure to create and safely store this recovery key. If you replace this system board, you must supply the recovery key when you restart your system or program before you can access the encrypted data on your hard drives.
- △ **CAUTION:** Do not attempt to remove the TPM plug-in module from the motherboard. After the TPM plug-in module is installed, it is cryptographically bound to that specific motherboard. Any attempt to remove an installed TPM plug-in module breaks the cryptographic binding, and it cannot be re-installed or installed on another motherboard.

- 1 Follow the safety guidelines listed in the safety instructions section.
- 2 Keep the Phillips #2 screwdriver ready.
- 3 Follow the procedure listed in the Before working inside your system section.
- 4 Remove the following:
 - a PCIe card holder
 - b Cooling shroud
 - c Cooling-fan assembly, if applicable
 - d Integrated storage controller card
 - e Internal dual SD module
 - f Internal USB key (if installed)
 - g Heat sink(s)
 - h Processors(s)
 - i  **NOTE:** To prevent damage to the processor pins when replacing a faulty system board, ensure that you cover the processor socket with the processor protective cap

Steps

- 1 Disconnect all cables from the system board.
 - △ **CAUTION:** Take care not to damage the system identification button while removing the system board from the chassis.
- 2 Holding the post, pull the blue release pin, and slide the system board toward the front of the system.
- 3 Holding the post, incline the system board at an angle, and lift the system board out of the chassis.
 - △ **CAUTION:** Do not lift the system board by holding a memory module, processor, or other components.

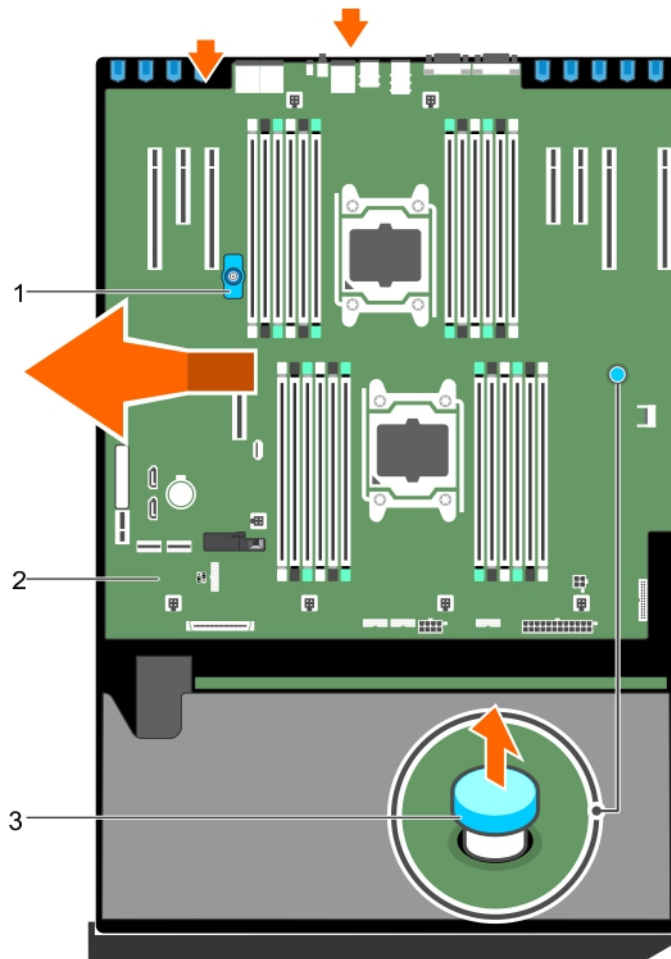

Figure 110. Removing the system board

- | | | | |
|---|-------------|---|--------------|
| 1 | post | 2 | system board |
| 3 | release pin | | |

Related links

- [Safety instructions](#)
- [Before working inside your system](#)
- [Installing the system board](#)

Installing the system board

Prerequisites

CAUTION: Many repairs may only be done by a certified service technician. You should only perform troubleshooting and simple repairs as authorized in your product documentation, or as directed by the online or telephone service and support team. Damage due to servicing that is not authorized by Dell is not covered by your warranty. Read and follow the safety instructions that are shipped with your product.

- 1 Follow the safety guidelines listed in the safety instructions section.
- 2 Keep the #2 Phillips screwdriver ready.
- 3 Follow the procedure listed in the Before working inside your system section.

Steps

- 1 Unpack the new system board assembly.

 **CAUTION: Do not lift the system board by holding a memory module, processor, or other components.**

- 2 Holding the post, incline the system board, and lower the system board into the chassis.
- 3 Push the system board toward the back of the chassis such that the ports on the system board align with the corresponding slots on the chassis.

Next steps

- 1 Install the Trusted Platform Module (TPM). For information on how to install TPM, see installing TPM section. For information on TPM, see the Trusted platform module section.

- 2 Install the following:

- a processors(s) and heat sink(s)
- b internal USB key (if installed)
- c internal dual SD module
- d integrated storage controller card
- e cooling-fan assembly, if applicable
- f cooling shroud
- g PCIe card holder

- 3 Reconnect all cables to the system board.

 **NOTE: Ensure that the cables inside the system are routed along the chassis wall and secured by using the cable securing bracket.**

- 4 Follow the procedure listed in the After working inside your system section.
- 5 Import your new or existing iDRAC Enterprise license. For more information, see the Integrated Dell Remote Access Controller User's Guide at dell.com/esmanuals.
- 6 Ensure that you:
 - a Use the **Easy Restore** feature to restore the service tag. For more information, see the Easy Restore section.
 - b If the service tag is not backed up in the backup flash device, enter the system service tag manually. For more information, see entering the system Service Tag section.
 - c Update the BIOS and iDRAC versions.
 - d Re-enable the Trusted Platform Module (TPM). For more information, see the Re-enabling the TPM for BitLocker users section or the Re-enabling the TPM for Intel TXT users section.

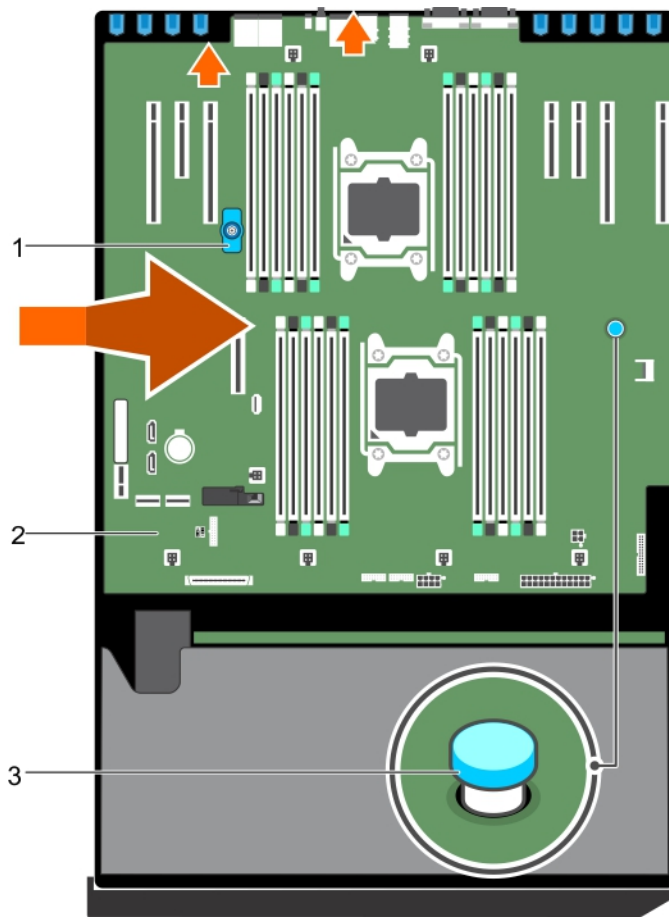

Figure 111. Installing the system board

- | | |
|------------------------------------|-----------------------|
| <p>1 post</p> <p>3 release pin</p> | <p>2 system board</p> |
|------------------------------------|-----------------------|

Related links

- [Safety instructions](#)
- [Before working inside your system](#)
- [Installing the Trusted Platform Module](#)

Entering the system Service Tag by using System Setup

If Easy Restore fails to restore the Service Tag, use System Setup to enter the Service Tag.

- 1 Turn on the system.
- 2 Press F2 to enter System Setup.
- 3 Click **Service Tag Settings**.
- 4 Enter the Service Tag.

NOTE: You can enter the Service Tag only when the Service Tag field is empty. Ensure that you enter the correct Service Tag. After the Service Tag is entered, it cannot be updated or changed.

- 5 Click **Ok**.
- 6 Import your new or existing iDRAC Enterprise license.

For more information, see the *Integrated Dell Remote Access Controller User's Guide* at Dell.com/idracmanuals.

Restoring the Service Tag by using the Easy Restore feature

The Easy Restore feature enables you to restore your system's Service Tag, license, UEFI configuration, and the system configuration data after replacing the system board. All data is automatically backed up in a backup flash device. If BIOS detects a new system board and the Service Tag in the backup flash device, BIOS prompts the user to restore the backup information.

- 1 Turn on the system.

If BIOS detects a new system board, and if the Service Tag is present in the backup flash device, BIOS displays the Service Tag, the status of the license, and the **UEFI Diagnostics** version.

- 2 Perform one of the following steps:

- Press **Y** to restore the Service Tag, license, and diagnostics information.
- Press **N** to navigate to the Dell Lifecycle Controller based restore options.
- Press F10 to restore data from a previously created **Hardware Server Profile**.

After the restore process is complete, BIOS prompts to restore the system configuration data.

- 3 Perform one of the following steps:

- Press **Y** to restore the system configuration data.
- Press **N** to use the default configuration settings.

After the restore process is complete, the system restarts.

Trusted Platform Module

Trusted Platform Module (TPM) is a dedicated microprocessor designed to secure hardware by integrating cryptographic keys into devices. A software can use a Trusted Platform Module to authenticate hardware devices. As each TPM chip has a unique and secret RSA key burned in as it is produced, it can perform the platform authentication.

⚠ CAUTION: Do not attempt to remove the Trusted Platform Module (TPM) from the system board. After the TPM is installed, it is cryptographically bound to that specific system board. Any attempt to remove an installed TPM breaks the cryptographic binding, and it cannot be re-installed or installed on another system board.

ℹ NOTE: This is a Field Replaceable Unit (FRU). Removal and installation procedures must be performed only by Dell certified service technicians.

Installing the Trusted Platform Module

Prerequisites

⚠ CAUTION: Many repairs may only be done by a certified service technician. You should only perform troubleshooting and simple repairs as authorized in your product documentation, or as directed by the online or telephone service and support team. Damage due to servicing that is not authorized by Dell is not covered by your warranty. Read and follow the safety instructions that came with the product.

- 1 Follow the safety guidelines listed in the Safety instructions section.
- 2 Follow the procedure listed in the Before working inside your system section.

Steps

- 1 Locate the Trusted Platform Module (TPM) connector on the system board.

ℹ NOTE: To locate the TPM connector on the system board, see the System board connectors section.

- 2 Align the edge connectors on the TPM with the slot on the TPM connector.
- 3 Insert the TPM into the TPM connector such that the plastic bolt aligns with the slot on the system board.
- 4 Press the plastic bolt until the bolt snaps into place.

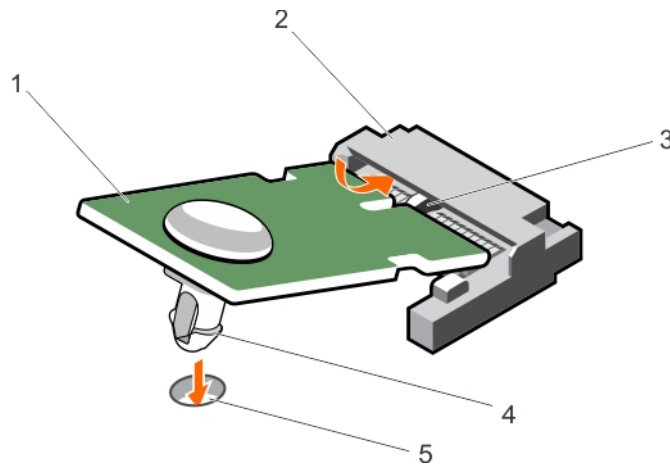

Figure 112. Installing the TPM

- | | | | |
|---|---------------------------|---|---------------|
| 1 | TPM | 2 | TPM connector |
| 3 | slot on the TPM connector | 4 | plastic bolt |
| 5 | slot on the system board | | |

Next steps

- 1 Install the system board.
- 2 Follow the procedure listed in the After working inside your system section.

Related links

- [Safety instructions](#)
- [Before working inside your system](#)

Initializing the TPM for BitLocker users

Initialize the TPM.

For more information about initializing the TPM, see <http://technet.microsoft.com/en-us/library/cc753140.aspx>.

The **TPM Status** changes to **Enabled, Activated**.

Initializing the TPM for TXT users

- 1 While booting your system, press F2 to enter System Setup.
- 2 On the **System Setup Main Menu** screen, click **System BIOS** → **System Security Settings**.
- 3 From the **TPM Security** option, select **On with Pre-boot Measurements**.
- 4 From the **TPM Command** option, select **Activate**.
- 5 Save the settings.
- 6 Restart your system.
- 7 Enter **System Setup** again.
- 8 On the **System Setup Main Menu** screen, click **System BIOS** → **System Security Settings**.
- 9 From the **Intel TXT** option, select **On**.

Power interposer board and power distribution board

Removing the power interposer board

Prerequisites

CAUTION: Many repairs may only be done by a certified service technician. You should only perform troubleshooting and simple repairs as authorized in your product documentation, or as directed by the online or telephone service and support team. Damage due to servicing that is not authorized by Dell is not covered by your warranty. Read and follow the safety instructions that are shipped with your product.

- 1 Follow the safety guidelines listed in the Safety instructions section.
- 2 Follow the procedure listed in the Before working inside your system section.

CAUTION: To prevent damage to the power interposer board (PIB), you must remove the power supply module(s) from the system before removing the power interposer board or power distribution board (PDB).

- 3 Remove the power supply module(s) from the back of the chassis.
- 4 Remove the PCIe card holders.
- 5 Remove the cooling shroud.
- 6 If connected, remove the cooling fan assembly.
- 7 Disconnect the power cables from the system board and the hard-drive backplane.
- 8 Remove the system board. For more information, see the Removing the system board section.

Steps

- 1 Pull the release pin and detach the PIB from the PDB.
- 2 Slide and lift the PIB up until the grooves on the PIB disengage from the pins on the chassis.

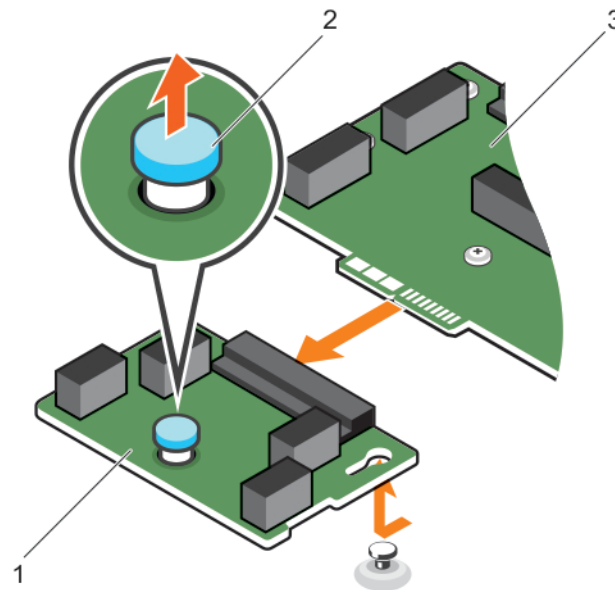

Figure 113. Removing the power interposer board

- | | | | |
|---|--------------------------|---|-------------|
| 1 | power interposer board | 2 | release pin |
| 3 | power distribution board | | |

Related links

- [Safety instructions](#)
- [Before working inside your system](#)
- [Removing the system board](#)
- [Installing the power interposer board](#)

Removing the power distribution board

Prerequisites

⚠ CAUTION: Many repairs may only be done by a certified service technician. You should only perform troubleshooting and simple repairs as authorized in your product documentation, or as directed by the online or telephone service and support team. Damage due to servicing that is not authorized by Dell is not covered by your warranty. Read and follow the safety instructions that are shipped with your product.

- 1 Follow the safety guidelines listed in the safety instructions section.
- 2 Keep the #2 Phillips screwdriver ready.
- 3 Follow the procedure listed in the Before working inside your system section.

⚠ CAUTION: To prevent damage to the power interposer board (PIB), you must remove the power supply module(s) from the system before removing the power interposer board or power distribution board (PDB).

- 4 Disconnect the power supply module(s) from the back of the chassis.
- 5 Remove the PCIe card holders.
- 6 Remove the cooling shroud.
- 7 If applicable, remove the cooling fan assembly.
- 8 Disconnect the power cables from the system board and the hard-drive backplane.
- 9 Remove the system board. For more information, see the Removing the system board section.
- 10 Remove the power interposer board.

Steps

- 1 Disconnect the power cables from the power distribution board (PDB).
- 2 Remove the six screws that secure the PDB to the chassis.
- 3 Lift the PDB up and out of the chassis.

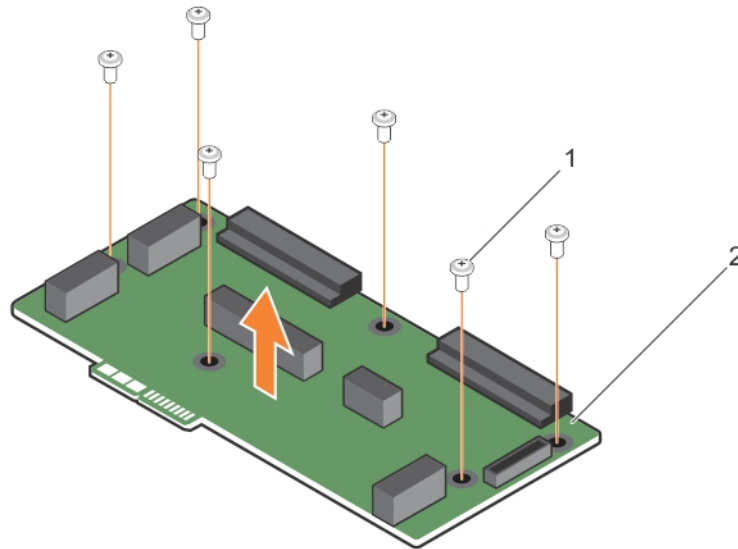

Figure 114. Removing the power distribution board

1 screws (6)

2 power distribution board

Related links

- [Safety instructions](#)
- [Installing the power distribution board](#)
- [Before working inside your system](#)

Installing the power distribution board

Prerequisites

⚠ CAUTION: Many repairs may only be done by a certified service technician. You should only perform troubleshooting and simple repairs as authorized in your product documentation, or as directed by the online or telephone service and support team. Damage due to servicing that is not authorized by Dell is not covered by your warranty. Read and follow the safety instructions that are shipped with your product.

- 1 Follow the safety guidelines listed in the Safety instructions section.
- 2 Keep the Phillips #2 screwdriver ready.

Steps

- 1 Align the screw holes on the power distribution board (PDB) with the holes on the chassis.
- 2 Secure the PDB on to the chassis by using the six screws.
- 3 Connect the power cables to the PDB.

Next steps

- 1 Install the power interposer board.
- 2 Install the system board. For more information, see the Installing system board section.
- 3 Connect the power cables to the system board and the hard-drive backplane.
- 4 If applicable, install the cooling fan assembly.
- 5 Install the cooling shroud.
- 6 Install the PCIe card holders.
- 7 Install the power supply module(s) in their original locations.

- 8 Follow the procedure listed in the After working inside your system section.

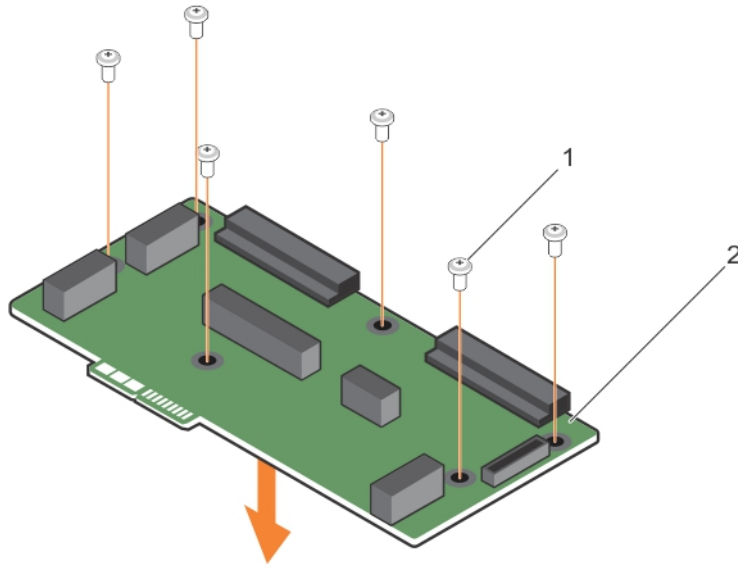

Figure 115. Installing the power distribution board

1 screws (6)

2 power distribution board

Related links

[Safety instructions](#)

[After working inside your system](#)

[Removing the power distribution board](#)

Installing the power interposer board

Prerequisite

CAUTION: Many repairs may only be done by a certified service technician. You should only perform troubleshooting and simple repairs as authorized in your product documentation, or as directed by the online or telephone service and support team. Damage due to servicing that is not authorized by Dell is not covered by your warranty. Read and follow the safety instructions that are shipped with your product.

Follow the safety guidelines listed in the safety instructions section.

Steps

- 1 Install the power distribution board (PDB).
- 2 Align the power interposer board (PIB) connector with the connector on the PDB.
- 3 Align the grooves on the PIB aligned with the pins on the chassis, and then connect the PIB to the connector on the PDB.

Next steps

- 1 Install the system board. For more information, see the Installing system board section.
- 2 Connect the power cables to the system board and the hard-drive backplane.
- 3 If applicable, install the cooling fan assembly.
- 4 Install the cooling shroud.
- 5 Install the PCIe card holders.
- 6 Install the power supply module(s) in their original locations.
- 7 Follow the procedure listed in the After working inside your system section.

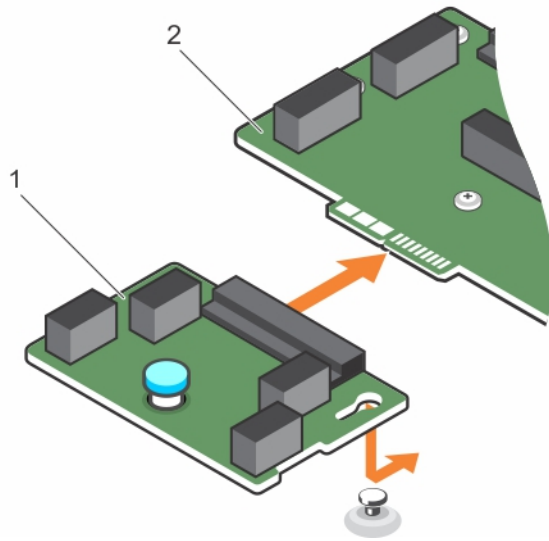

Figure 116. Installing the power interposer board

1 power interposer board

2 power distribution board

Related links

[Safety instructions](#)

[Installing the power interposer board](#)

[After working inside your system](#)

Using system diagnostics

If you experience a problem with your system, run the system diagnostics before contacting Dell for technical assistance. The purpose of running system diagnostics is to test your system hardware without requiring additional equipment or risking data loss. If you are unable to fix the problem yourself, service and support personnel can use the diagnostics results to help you solve the problem.

Dell Embedded System Diagnostics

NOTE: The Dell Embedded System Diagnostics is also known as Enhanced Pre-boot System Assessment (ePSA) diagnostics.

The Embedded System Diagnostics provides a set of options for particular device groups or devices allowing you to:

- Run tests automatically or in an interactive mode
- Repeat tests
- Display or save test results
- Run thorough tests to introduce additional test options to provide extra information about the failed device(s)
- View status messages that inform you if tests are completed successfully
- View error messages that inform you of problems encountered during testing

Running the Embedded System Diagnostics from Boot Manager

Prerequisite

Run the Embedded System Diagnostics (ePSA) if your system does not boot.

Steps

- 1 When the system is booting, press F11.
- 2 Use the up arrow and down arrow keys to select **System Utilities > Launch Diagnostics**.

The **ePSA Pre-boot System Assessment** window is displayed, listing all devices detected in the system. The diagnostics starts executing the tests on all the detected devices.

Running the Embedded System Diagnostics from the Dell Lifecycle Controller

- 1 As the system boots, press F10.
- 2 Select **Hardware Diagnostics** → **Run Hardware Diagnostics**.

The **ePSA Pre-boot System Assessment** window is displayed, listing all devices detected in the system. The diagnostics starts executing the tests on all the detected devices.

System diagnostic controls

Menu	Description
Configuration	Displays the configuration and status information of all detected devices.
Results	Displays the results of all tests that are run.
System health	Provides the current overview of the system performance.
Event log	Displays a time-stamped log of the results of all tests run on the system. This is displayed if at least one event description is recorded.

For information about embedded system diagnostics, see the *ePSA Diagnostics Guide (Notebooks, Desktops and Servers)* available at Dell.com/support/home.

Jumpers and connectors

This topic provides specific information about the system jumpers. It also provides some basic information about jumpers and switches and describes the connectors on the various boards in the system. Jumpers on the system board help to disable system and setup passwords. You must know the connectors on the system board to install components and cables correctly.

Topics:

- [System board connectors](#)
- [System board jumper settings](#)
- [Disabling a forgotten password](#)

System board connectors

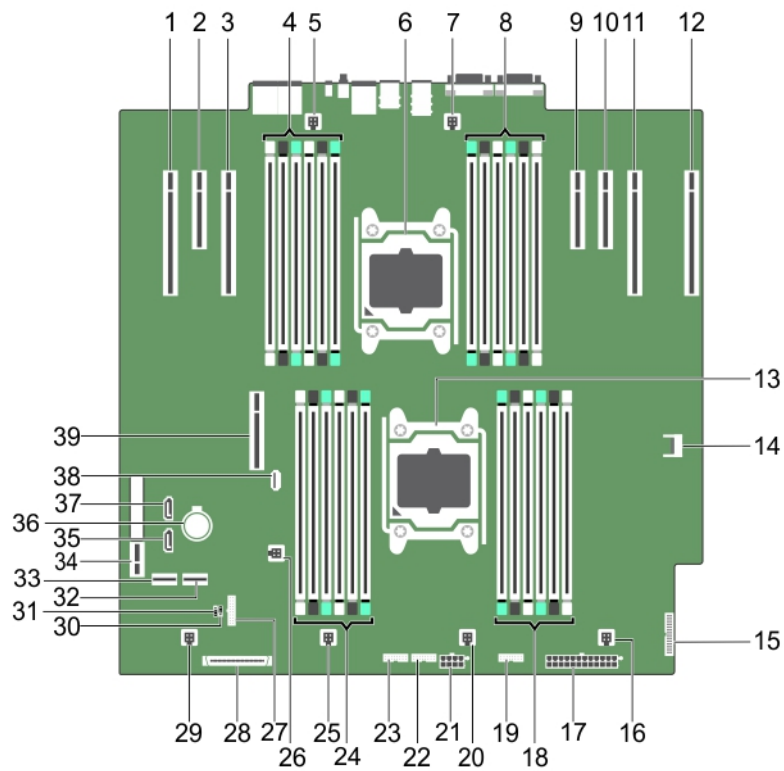

Figure 117. System board jumpers and connectors

Table 37. System board jumpers and connector description





Item	Connector	Description
1	SLOT1 PCIE_G3_X16 (CPU1)	PCIe card connector 1
2	SLOT2 PCIE_G2_X4 (PCH)	PCIe card connector 2

Item	Connector	Description
3	SLOT3 PCIE_G3_X16 (CPU1)	PCIe card connector 3
4	B1, B5, B9, B2, B6, B10	Memory module sockets
5	FAN1	Cooling shroud fan connector
6	CPU2	Processor 2
7	FAN2	Fan connector
8	B12, B8, B4, B11, B7, B3	Memory module sockets
9	SLOT4 PCIE_G3_X8 (CPU2)	PCIe card connector 4
10	SLOT5 PCIE_G2_X4 (CPU2)	PCIe card connector 5
11	SLOT6 PCIE_G3_X16 (CPU2)	PCIe card connector 6
12	SLOT7 PCIE_G3_X16 (CPU2)	PCIe card connector 7
13	CPU1	Processor 1
14	TPM_Module	Trusted Platform Module (TPM) connector
15	PIB_CONN	PIB signal connector
16	FAN6	Fan connector
17	PWR_CONN_2	PIB signal connector
18	A10, A6, A2, A9, A5, A1	Memory module sockets
19	BP_SIG2	Backplane signal connector 2
20	FAN5	Cooling shroud fan connector
21	PWR_CONN_1	Power connector
22	BP_SIG1	Backplane signal connector 1
23	BP_SIG0	Dell PowerEdge Express Flash (PCIe SSD) signal connector
24	A3, A7, A11, A4, A8, A12	Memory module sockets
25	FAN4	Cooling shroud fan connector
26	INTRUSION	Chassis intrusion switch connector
27	FP_USB	Control panel USB connector
28	CTRL_PNL	Control panel interface connector
29	FAN3	Cooling shroud fan connector
30	PWRD_EN	See System board jumper settings
31	NVRAM_CLR	See System board jumper settings
32	SW RAID_B	SW RAID connector 2
33	SW RAID_A	SW RAID connector 1
34	IDSDM	Internal dual SD module connector
35	SATA_TBU	Tape drive SATA connector
36	BATTERY	System battery connector
37	SATA_CDRROM	Optical drive SATA connector
38	INT_USB_3.0	Internal USB 3.0 connector

Item	Connector	Description
39	SLOT8 PCIE_G3_X8 (CPU1)	PCIe card connector 8

System board jumper settings

Table 38. System board jumper settings

Jumper	Setting	Description
PWRD_EN	 (default)	The password reset feature is enabled (pins 2–4). BIOS local access is unlocked at the next AC power cycle.
		The password reset feature is disabled (pins 4–6).
NVRAM_CLR	 (default)	The configuration settings are retained at the next system boot (pins 3–5).
		The configuration settings are cleared at system boot (pins 1–3).

Disabling a forgotten password

The software security features of the system include a system password and a setup password. The password jumper enables these password features or disables them and clears any password(s) currently in use.

Prerequisite

CAUTION: Many repairs may only be done by a certified service technician. You should only perform troubleshooting and simple repairs as authorized in your product documentation, or as directed by the online or telephone service and support team. Damage due to servicing that is not authorized by Dell is not covered by your warranty. Read and follow the safety instructions that are shipped with your product.

Steps

- 1 Turn off the system, including any attached peripherals, and disconnect the system from the electrical outlet.
 - 2 Remove the system cover.
 - 3 Move the jumper on the system board jumper from pins 4 and 6 to pins 2 and 4.
 - 4 Install the system cover.

The existing passwords are not disabled (erased) until the system boots with the jumper on pins 2 and 4. However, before you assign a new system and/or setup password, you must move the jumper back to pins 4 and 6.
- NOTE:** If you assign a new system and/or setup password with the jumper on pins 2 and 4, the system disables the new password(s) the next time it boots.
- 5 Reconnect the system to its electrical outlet and turn the system on, including any attached peripherals.
 - 6 Turn off the system, including any attached peripherals, and disconnect the system from the electrical outlet.
 - 7 Remove the system cover.
 - 8 Move the jumper on the system board jumper from pins 2 and 4 to pins 4 and 6.
 - 9 Install the system cover.
 - 10 Reconnect the system to its electrical outlet and turn the system on, including any attached peripherals.
 - 11 Assign a new system and/or setup password.

Related links

- [Removing the system cover](#)
- [Installing the system cover](#)

Troubleshooting your system

Safety first — for you and your system

⚠ CAUTION: Many repairs may only be done by a certified service technician. You should only perform troubleshooting and simple repairs as authorized in your product documentation, or as directed by the online or telephone service and support team. Damage due to servicing that is not authorized by Dell is not covered by your warranty. Read and follow the safety instructions that are shipped with your product.

ℹ NOTE: Solution validation was performed by using the factory shipped hardware configuration.

Topics:

- [Troubleshooting system startup failure](#)
- [Troubleshooting external connections](#)
- [Troubleshooting the video subsystem](#)
- [Troubleshooting a USB device](#)
- [Troubleshooting a serial I/O device](#)
- [Troubleshooting a NIC](#)
- [Troubleshooting a wet system](#)
- [Troubleshooting a damaged system](#)
- [Troubleshooting the system battery](#)
- [Troubleshooting power supply units](#)
- [Troubleshooting cooling problems](#)
- [Troubleshooting cooling fans](#)
- [Troubleshooting system memory](#)
- [Troubleshooting an internal USB key](#)
- [Troubleshooting an SD card](#)
- [Troubleshooting an optical drive](#)
- [Troubleshooting a hard drive](#)
- [Troubleshooting a storage controller](#)
- [Troubleshooting expansion cards](#)
- [Troubleshooting processors](#)

Troubleshooting system startup failure

If you boot the system to the BIOS boot mode after installing an operating system from the UEFI Boot Manager, the system stops responding. To avoid this issue, you must boot to the same boot mode in which you installed the operating system.

For all other startup issues, note the system messages that appear on the screen.

Troubleshooting external connections

Before troubleshooting any external devices, ensure that all external cables are securely attached to the external connectors on your system before troubleshooting any external devices.

Troubleshooting the video subsystem

Prerequisite

NOTE: Ensure the **Local Server Video Enabled** option is selected in the iDRAC Graphical User Interface (GUI), under **Virtual Console**. If this option is not selected, local video is disabled.

Steps

- 1 Check the cable connections (power and display) to the monitor.
- 2 Check the video interface cabling from the system to the monitor.
- 3 Run the appropriate diagnostic test.

If the tests run successfully, the problem is not related to video hardware.

Next step

If the tests fail, see the Getting help section.

Related link

[Getting help](#)

Troubleshooting a USB device

Prerequisite

NOTE: Follow steps 1 to 6 to troubleshoot a USB keyboard or mouse. For other USB devices, go to step 7.

Steps

- 1 Disconnect the keyboard and/or mouse cables from the system and reconnect them.
- 2 If the problem persists, connect the keyboard and/or mouse to another USB port on the system.
- 3 If the problem is resolved, restart the system, enter System Setup, and check if the non-functioning USB ports are enabled.
NOTE: Older operating systems may not support USB 3.0.
- 4 Check if USB 3.0 is enabled in System Setup. If enabled, disable it and see if the issue is resolved.
- 5 In **iDRAC Settings Utility**, ensure that **USB Management Port Mode** is configured as **Automatic** or **Standard OS Use**.
- 6 If the problem is not resolved, replace the keyboard and/or mouse with a known working keyboard or mouse.
If the problem is not resolved, proceed to step 7 to troubleshoot other USB devices attached to the system.
- 7 Turn off all attached USB devices, and disconnect them from the system.
- 8 Restart the system.
- 9 If your keyboard is functioning, enter System Setup, verify that all USB ports are enabled on the **Integrated Devices** screen. If your keyboard is not functioning, use remote access to enable or disable the USB options.
- 10 Check if USB 3.0 is enabled in System Setup. If it is enabled, disable it and restart your system.
- 11 If the system is not accessible, reset the NVRAM_CLR jumper inside your system and restore the BIOS to the default settings. See the System board jumper setting section.
- 12 In the **iDRAC Settings Utility**, ensure that **USB Management Port Mode** is configured as **Automatic** or **Standard OS Use**.
- 13 Reconnect and turn on each USB device one at a time.
- 14 If a USB device causes the same problem, turn off the device, replace the USB cable with a known good cable, and turn on the device.

Next step

If all troubleshooting fails, see the Getting help section.

Related link

[Getting help](#)

Troubleshooting a serial I/O device

Steps

- 1 Turn off the system and any peripheral devices connected to the serial port.
- 2 Swap the serial interface cable with a known working cable, and turn on the system and the serial device.
If the problem is resolved, replace the interface cable with a known working cable.
- 3 Turn off the system and the serial device, and swap the serial device with a compatible device.
- 4 Turn on the system and the serial device.

Next step

If the problem persists, see the Getting help section.

Related link

[Getting help](#)

Troubleshooting a NIC

Steps

- 1 Run the appropriate diagnostic test. For more information, see the Using system diagnostics section for the available diagnostic tests.
- 2 Restart the system and check for any system messages pertaining to the NIC controller.
- 3 Check the appropriate indicator on the NIC connector:
 - If the link indicator does not glow, the cable connected might be disengaged.
 - If the activity indicator does not glow, the network driver files might be damaged or missing.
Install or replace the drivers as necessary. For more information, see the NIC documentation.
 - If the problem persists, use another connector on the switch or hub.
- 4 Ensure that the appropriate drivers are installed and the protocols are bound. For more information, see the NIC documentation.
- 5 Enter System Setup and confirm that the NIC ports are enabled on the **Integrated Devices** screen.
- 6 Ensure that all the NICs, hubs, and switches on the network are set to the same data transmission speed and duplex. For more information, see the documentation for each network device.
- 7 Ensure that all network cables are of the proper type and do not exceed the maximum length.

Next step

If the problem persists, see the Getting help section.

Related link

[Getting help](#)

Troubleshooting a wet system

Prerequisite

 **CAUTION:** Many repairs may only be done by a certified service technician. You should only perform troubleshooting and simple repairs as authorized in your product documentation, or as directed by the online or telephone service and support team. Damage due to servicing that is not authorized by Dell is not covered by your warranty. Read and follow the safety instructions that are shipped with your product.

Steps

- 1 Turn off the system and attached peripherals, and disconnect the system from the electrical outlet.
- 2 Remove the system cover.
- 3 Remove the following components (if installed) from the system:
 - power supply unit(s)
 - optical drive
 - hard drives
 - hard drive backplane
 - USB memory key
 - hard drive tray
 - cooling shroud
 - expansion card risers (if installed)
 - expansion cards
 - cooling fan assembly (if installed)
 - cooling fans
 - memory modules
 - processor(s) and heat sink(s)
 - system board
- 4 Let the system dry thoroughly for at least 24 hours.
- 5 Reinstall the components you removed in step 3 except the expansion cards.
- 6 Install the system cover.
- 7 Turn on the system and attached peripherals.
If the problem persists, see the Getting help section.
- 8 If the system starts properly, shut down the system, and reinstall all the expansion cards that you removed.
- 9 Run the appropriate diagnostic test. For more information, see the Using system diagnostics section.

Next step

If the tests fail, see the Getting help section.

Related link

[Getting help](#)

Troubleshooting a damaged system

Prerequisite

⚠ CAUTION: Many repairs may only be done by a certified service technician. You should only perform troubleshooting and simple repairs as authorized in your product documentation, or as directed by the online or telephone service and support team. Damage due to servicing that is not authorized by Dell is not covered by your warranty. Read and follow the safety instructions that are shipped with your product.

Steps

- 1 Turn off the system and attached peripherals, and disconnect the system from the electrical outlet.
- 2 Remove the system cover.
- 3 Ensure that the following components are properly installed:
 - cooling shroud
 - expansion card risers (if installed)
 - expansion cards
 - power supply unit(s)
 - cooling fan assembly (if installed)

- cooling fans
 - processor(s) and heat sink(s)
 - memory modules
 - hard drive carriers/cage
 - hard drive backplane
- 4 Ensure that all cables are properly connected.
 - 5 Install the system cover.
 - 6 Run the appropriate diagnostic test. For more information, see the Using system diagnostics section.

Next step

If the problem persists, see the Getting help section.

Related link

[Getting help](#)

Troubleshooting the system battery

Prerequisites

⚠ CAUTION: Many repairs may only be done by a certified service technician. You should only perform troubleshooting and simple repairs as authorized in your product documentation, or as directed by the online or telephone service and support team. Damage due to servicing that is not authorized by Dell is not covered by your warranty. Read and follow the safety instructions that are shipped with your product.

ℹ NOTE: If the system is turned off for long periods of time (for weeks or months), the NVRAM may lose its system configuration information. This situation is caused by a defective battery.

ℹ NOTE: Some software may cause the system time to speed up or slow down. If the system seems to operate normally except for the time set in System Setup, the problem may be caused by a software, rather than by a defective battery.

Steps

- 1 Re-enter the time and date in System Setup.
- 2 Turn off the system, and disconnect it from the electrical outlet for at least an hour.
- 3 Reconnect the system to the electrical outlet, and turn on the system.
- 4 Enter System Setup.
If the date and time displayed in System Setup are not correct, check the System Error Log (SEL) for system battery messages.

Next step

If the problem persists, see the Getting help section.

Related link

[Getting help](#)

Troubleshooting power supply units

⚠ CAUTION: Many repairs may only be done by a certified service technician. You should only perform troubleshooting and simple repairs as authorized in your product documentation, or as directed by the online or telephone service and support team. Damage due to servicing that is not authorized by Dell is not covered by your warranty. Read and follow the safety instructions that are shipped with your product.

Troubleshooting power source problems

- 1 Press the power button to ensure that your system is turned on. If the power indicator does not glow when the power button is pressed, press the power button firmly.
- 2 Plug in another working power supply unit to ensure that the system board is not faulty.

- 3 Ensure that no loose connections exist.
For example, loose power cables.
- 4 Ensure that the power source meets applicable standards.
- 5 Ensure that there are no short circuits.
- 6 Have a qualified electrician check the line voltage to ensure that it meets the needed specifications.

Power supply unit problems

- 1 Ensure that no loose connections exist.
For example, loose power cables.
- 2 Ensure that the power supply handle or LED indicates that the power supply is working properly.
For more information about power supply indicators, see the Power indicator codes section.
- 3 If you have recently upgraded your system, ensure that the power supply unit (PSU) has enough power to support the new system.
- 4 If you have a redundant power supply configuration, ensure that both the PSUs are of the same type and wattage.
You may have to upgrade to a higher wattage PSU.
- 5 Ensure that you use only PSUs with the Extended Power Performance (EPP) label on the back.
- 6 Reseat the PSU.

 **NOTE:** After installing a PSU, allow several seconds for the system to recognize the PSU and determine if it is working properly.

If the problem persists, see the Getting help section.

Troubleshooting cooling problems

 **CAUTION:** Many repairs may only be done by a certified service technician. You should only perform troubleshooting and simple repairs as authorized in your product documentation, or as directed by the online or telephone service and support team. Damage due to servicing that is not authorized by Dell is not covered by your warranty. Read and follow the safety instructions that are shipped with your product.

Ensure that the following conditions exist:

- System cover, cooling shroud, EMI filler panel, memory module blank, or back filler bracket is not removed.
- Ambient temperature is not higher than the system specific ambient temperature.
- External airflow is not obstructed.
- A cooling fan is not removed or has not failed.
- The expansion card installation guidelines have been followed.

Additional cooling can be added by one of the following methods:

From the iDRAC web GUI:

- 1 Click **Hardware > Fans > Setup**.
- 2 From the **Fan Speed Offset** drop-down list, select the cooling level required or set the minimum fan speed to a custom value.

From F2 System Setup:

- 1 Select **iDRAC Settings > Thermal**, and set a higher fan speed from the fan speed offset or minimum fan speed.

From RACADM commands:

- 1 Run the command `racadm help system.thermalsettings`

For more information, see the Integrated Dell Remote Access User's Guide at [Dell.com/idracmanuals](https://www.dell.com/idracmanuals).

Related link

[Getting help](#)

Troubleshooting cooling fans

Prerequisites

⚠ CAUTION: Many repairs may only be done by a certified service technician. You should only perform troubleshooting and simple repairs as authorized in your product documentation, or as directed by the online or telephone service and support team. Damage due to servicing that is not authorized by Dell is not covered by your warranty. Read and follow the safety instructions that are shipped with your product.

ℹ NOTE: The fan number is referenced by the systems management software. In the event of a problem with a particular fan, you can easily identify and replace it by noting down the fan numbers on the cooling fan assembly.

- 1 Follow the safety guidelines listed in safety instructions section.
- 2 Follow the procedure listed in the Before working inside your system section.

Steps

- 1 Remove the system cover.
- 2 Reseat the fan or the fan's power cable.
- 3 Install the system cover.
- 4 Restart the system.

Next step

If the problem persists, see the Getting help section.

Related link

[Getting help](#)

Troubleshooting system memory

Prerequisite

⚠ CAUTION: Many repairs may only be done by a certified service technician. You should only perform troubleshooting and simple repairs as authorized in your product documentation, or as directed by the online or telephone service and support team. Damage due to servicing that is not authorized by Dell is not covered by your warranty. Read and follow the safety instructions that are shipped with your product.

Steps

- 1 If the system is operational, run the appropriate system diagnostic test. See the Using system diagnostics section for the available diagnostic tests.
If the diagnostic tests indicate a fault, follow the corrective actions provided by the diagnostic tests.
- 2 If the system is not operational, turn off the system and attached peripherals, and unplug the system from the power source. Wait at least for 10 seconds, and then reconnect the system to the power source.
- 3 Turn on the system and attached peripherals, and note the messages on the screen.
If an error message is displayed indicating a fault with a specific memory module, go to step 12.
- 4 Enter System Setup, and check the system memory setting. Make any changes to the memory settings, if needed.
If the memory settings match the installed memory but the problem still persists, go to step 12.
- 5 Turn off the system and attached peripherals, and disconnect the system from the electrical outlet.
- 6 Remove the system cover.
- 7 Check the memory channels and ensure that they are populated correctly.

ℹ NOTE: See the system event log or system messages for the location of the failed memory module. Reinstall the memory device.

- 8 Reseat the memory modules in their sockets.

- 9 Install the system cover.
- 10 Enter System Setup and check the system memory setting.
If the problem is not resolved, proceed with step 11.
- 11 Remove the system cover.
- 12 If a diagnostic test or error message indicates a specific memory module as faulty, swap or replace the module with a known working memory module.
- 13 To troubleshoot an unspecified faulty memory module, replace the memory module in the first DIMM socket with a module of the same type and capacity.
If an error message is displayed on the screen, this may indicate a problem with the installed DIMM type(s), incorrect DIMM installation, or defective DIMM(s). Follow the on-screen instructions to resolve the problem.
- 14 Install the system cover.
- 15 As the system boots, observe any error message that is displayed and the diagnostic indicators on the front of the system.
- 16 If the memory problem persists, repeat step 12 through step 15 for each memory module installed.

Next step

If the problem persists, see the Getting help section.

Related link

[Getting help](#)

Troubleshooting an internal USB key

Prerequisite

⚠ CAUTION: Many repairs may only be done by a certified service technician. You should only perform troubleshooting and simple repairs as authorized in your product documentation, or as directed by the online or telephone service and support team. Damage due to servicing that is not authorized by Dell is not covered by your warranty. Read and follow the safety instructions that are shipped with your product.

Steps

- 1 Enter System Setup and ensure that the **USB key port** is enabled on the **Integrated Devices** screen.
- 2 Turn off the system and attached peripherals, and disconnect the system from the electrical outlet.
- 3 Remove the system cover.
- 4 Locate the USB key and reseal it.
- 5 Install the system cover.
- 6 Turn on the system and attached peripherals, and check if the USB key is functioning.
- 7 If the problem is not resolved, repeat step 2 and step 3.
- 8 Insert a known working USB key.
- 9 Install the system cover.

Next step

If the problem persists, see the Getting help section.

Related link

[Getting help](#)

Troubleshooting an SD card

Prerequisites

⚠ CAUTION: Many repairs may only be done by a certified service technician. You should only perform troubleshooting and simple repairs as authorized in your product documentation, or as directed by the online or telephone service and support team. Damage due to servicing that is not authorized by Dell is not covered by your warranty. Read and follow the safety instructions that are shipped with your product.

NOTE: Certain SD cards have a physical write-protect switch on the card. If the write-protect switch is turned on, the SD card is not writable.

Steps

- 1 Enter System Setup, and ensure that the **Internal SD Card Port** is enabled.
- 2 Turn off the system, including any attached peripherals, and disconnect the system from the electrical outlet.
- 3 Remove the system cover.

NOTE: When an SD card failure occurs, the internal dual SD module controller notifies the system. On the next restart, the system displays a message indicating the failure. If redundancy is enabled at the time of SD card failure, a critical alert will be logged and chassis health will degrade.

- 4 Replace the failed SD card with a new SD card.
- 5 Install the system cover.
- 6 Reconnect the system to its electrical outlet and turn on the system, including any attached peripherals.
- 7 Enter System Setup, and ensure that the **Internal SD Card Port** and **Internal SD Card Redundancy** modes are set to the needed modes.
Verify that the correct SD slot is set as **Primary SD Card**.
- 8 Check if the SD card is functioning properly.
- 9 If the **Internal SD Card Redundancy** option is set to **Enabled** at the time of the SD card failure, the system prompts you to perform a rebuild.

NOTE: The rebuild is always sourced from the primary SD card to the secondary SD card.

Related link

[Getting help](#)

Troubleshooting an optical drive

Prerequisite

CAUTION: Many repairs may only be done by a certified service technician. You should only perform troubleshooting and simple repairs as authorized in your product documentation, or as directed by the online or telephone service and support team. Damage due to servicing that is not authorized by Dell is not covered by your warranty. Read and follow the safety instructions that are shipped with your product.

Steps

- 1 Try using a different CD or DVD.
- 2 If the problem is not resolved, enter System Setup and ensure that the integrated SATA controller and the drive's SATA port are enabled.
- 3 Run the appropriate diagnostic test.
- 4 Turn off the system and attached peripherals, and disconnect the system from the electrical outlet.
- 5 If installed, remove the bezel.
- 6 Remove the system cover.
- 7 Ensure that the interface cable is securely connected to the optical drive and to the controller.
- 8 Ensure that a power cable is properly connected to the drive.
- 9 Install the system cover.

Next step

If the problem persists, see the Getting help section.

Related link

[Getting help](#)

Troubleshooting a hard drive

Prerequisites

⚠ CAUTION: This troubleshooting procedure can erase data stored on the hard drive. Before you proceed, back up all files on the hard drive.

⚠ CAUTION: Many repairs may only be done by a certified service technician. You should only perform troubleshooting and simple repairs as authorized in your product documentation, or as directed by the online or telephone service and support team. Damage due to servicing that is not authorized by Dell is not covered by your warranty. Read and follow the safety instructions that are shipped with your product.

Steps

- 1 Run the appropriate diagnostic test. See the Using system diagnostics section.
Depending on the results of the diagnostics test, proceed as needed through the following steps.
- 2 If your system has a RAID controller and your hard drives are configured in a RAID array, perform the following steps:
 - a Restart the system and press F10 during system startup to run the Dell Lifecycle Controller, and then run the Hardware Configuration wizard to check the RAID configuration.
See the Dell Lifecycle Controller documentation or online help for information about RAID configuration.
 - b Ensure that the hard drives are configured correctly for the RAID array.
 - c Take the hard drive offline and reseal the drive.
 - d Exit the configuration utility and allow the system to boot to the operating system.
- 3 Ensure that the needed device drivers for your controller card are installed and are configured correctly. See the operating system documentation for more information.
- 4 Restart the system and enter the System Setup.
- 5 Verify that the controller is enabled and the drives are displayed in the System Setup.

Next step

If the problem persists, see the Getting help section.

Related link

[Getting help](#)

Troubleshooting a storage controller

⚠ CAUTION: Many repairs may only be done by a certified service technician. You should only perform troubleshooting and simple repairs as authorized in your product documentation, or as directed by the online or telephone service and support team. Damage due to servicing that is not authorized by Dell is not covered by your warranty. Read and follow the safety instructions that are shipped with your product.

📘 NOTE: When troubleshooting a SAS or PERC controller, see the documentation for your operating system and the controller.

- 1 Run the appropriate diagnostic test. See the Using system diagnostics section.
- 2 Turn off the system and attached peripherals, and disconnect the system from the electrical outlet.
- 3 Remove the system cover.
- 4 Verify that the installed expansion cards are compliant with the expansion card installation guidelines.
- 5 Ensure that each expansion card is firmly seated in its connector.
- 6 Install the system cover.
- 7 Reconnect the system to the electrical outlet, and turn on the system and attached peripherals.
- 8 If the problem is not resolved, turn off the system and attached peripherals, and disconnect the system from the electrical outlet.
- 9 Remove the system cover.
- 10 Remove all expansion cards installed in the system.
- 11 Install the system cover.

- 12 Reconnect the system to the electrical outlet, and turn on the system and attached peripherals.
- 13 Run the appropriate diagnostic test. See the Using system diagnostics section. If the tests fail, see the Getting help section.
- 14 For each expansion card you removed in step 10, perform the following steps:
 - a Turn off the system and attached peripherals, and disconnect the system from the electrical outlet.
 - b Remove the system cover.
 - c Reinstall one of the expansion cards.
 - d Install the system cover.
 - e Run the appropriate diagnostic test. See the Using system diagnostics section.

If the problem persists, see the Getting help section.

Related link

[Getting help](#)

Troubleshooting expansion cards

Prerequisites

⚠ CAUTION: Many repairs may only be done by a certified service technician. You should only perform troubleshooting and simple repairs as authorized in your product documentation, or as directed by the online or telephone service and support team. Damage due to servicing that is not authorized by Dell is not covered by your warranty. Read and follow the safety instructions that are shipped with your product.

ℹ NOTE: When troubleshooting an expansion card, you also have to see the documentation for your operating system and the expansion card.

Steps

- 1 Run the appropriate diagnostic test. See the Using system diagnostics section.
- 2 Turn off the system and attached peripherals, and disconnect the system from the electrical outlet.
- 3 Remove the system cover.
- 4 Ensure that each expansion card is firmly seated in its connector.
- 5 Install the system cover.
- 6 Turn on the system and attached peripherals.
- 7 If the problem is not resolved, turn off the system and attached peripherals, and disconnect the system from the electrical outlet.
- 8 Remove the system cover.
- 9 Remove all expansion cards installed in the system.
- 10 Install the system cover.
- 11 Run the appropriate diagnostic test. See the Using system diagnostics section.
If the tests fail, see the Getting help section.
- 12 For each expansion card you removed in step 8, perform the following steps:
 - a Turn off the system and attached peripherals, and disconnect the system from the electrical outlet.
 - b Remove the system cover.
 - c Reinstall one of the expansion cards.
 - d Install the system cover.
 - e Run the appropriate diagnostic test. See the Using system diagnostics section.

Next step

If the problem persists, see the Getting help section.

Related link

[Getting help](#)

Troubleshooting processors

Prerequisite

⚠ CAUTION: Many repairs may only be done by a certified service technician. You should only perform troubleshooting and simple repairs as authorized in your product documentation, or as directed by the online or telephone service and support team. Damage due to servicing that is not authorized by Dell is not covered by your warranty. Read and follow the safety instructions that are shipped with your product.

Steps

- 1 Run the appropriate diagnostics test. See the Using system diagnostics section.
- 2 Turn off the system and attached peripherals, and disconnect the system from the electrical outlet.
- 3 Remove the system cover.
- 4 Ensure that the processor and heat sink are properly installed.
- 5 Install the system cover.
- 6 Run the appropriate diagnostic test. See the Using system diagnostics section.
- 7 If the problem persists, see the Getting help section.

Getting help

Topics:

- [Contacting Dell](#)
- [Documentation feedback](#)
- [Accessing system information by using QRL](#)

Contacting Dell

Dell provides several online and telephone-based support and service options. If you do not have an active internet connection, you can find contact information on your purchase invoice, packing slip, bill, or Dell product catalog. Availability varies by country and product, and some services may not be available in your area. To contact Dell for sales, technical assistance, or customer-service issues:

- 1 Go to **Dell.com/support**.
- 2 Select your country from the drop-down menu on the bottom right corner of the page.
- 3 For customized support:
 - a Enter your system Service Tag in the **Enter your Service Tag** field.
 - b Click **Submit**.The support page that lists the various support categories is displayed.
- 4 For general support:
 - a Select your product category.
 - b Select your product segment.
 - c Select your product.The support page that lists the various support categories is displayed.
- 5 For contact details of Dell Global Technical Support:
 - a Click [Global Technical Support](#).
 - b The **Technical Support** page is displayed with details to call, chat, or e-mail the Dell Global Technical Support team.

Documentation feedback

You can rate the documentation or write your feedback on any of our Dell documentation pages and click **Send Feedback** to send your feedback.

Accessing system information by using QRL

You can use the Quick Resource Locator (QRL) to get immediate access to the information about your system.

Prerequisite

Ensure that your smartphone or tablet has the QR code scanner installed.

The QRL includes the following information about your system:

About this task

- How-to videos
- Reference materials, including the Owner's Manual, LCD diagnostics, and mechanical overview
- Your system service tag to quickly access your specific hardware configuration and warranty information

- A direct link to Dell to contact technical assistance and sales teams

Steps

- 1 Go to **Dell.com/QRL** and navigate to your specific product or
- 2 Use your smartphone or tablet to scan the model-specific Quick Resource (QR) code on your Dell PowerEdge system or in the Quick Resource Locator section.

Quick Resource Locator (QRL) for PowerEdge T630

